



Low-Power μ P Reset Circuits in 3-Pin SC70/SOT23

General Description

The MXD1810–MXD1813/MXD1815–MXD1818 family of microprocessor (μ P) reset circuits monitor power supplies in μ P and digital systems. These devices provide excellent circuit reliability and low cost by eliminating external components and adjustments when used with +2.5V/+3.0V/+3.3V (MXD1815–MXD1818), and +5V (MXD1810–MXD1813) systems.

These circuits assert a reset signal whenever the V_{CC} supply voltage declines below a preset threshold, keeping reset asserted for at least 100ms after V_{CC} rises above the reset threshold. The MXD1813/MXD1818 also keep reset asserted for at least 100ms after the output is momentarily pulled to GND by an external push-button switch.

The MXD1812/MXD1817 have an active-high push-pull RESET output. The MXD1810/MXD1815 (push-pull) and MXD1811/MXD1813/MXD1816/MXD1818 (open-drain) have an active-low $\overline{\text{RESET}}$ output. The open-drain devices (MXD1811/MXD1813/MXD1816/MXD1818) have an internal pullup resistor to V_{CC} . The MXD1813/MXD1818 feature a debounced manual reset feature that asserts a reset if the $\overline{\text{RESET}}$ pin is pulled low for more than 1.5 μ s. When used to initiate manual reset, $\overline{\text{RESET}}$ debounces signals from devices such as mechanical switches. For devices with this feature, the release of the external switch triggers the reset period.

The MXD1810–MXD1813/MXD1815–MXD1818 are guaranteed to output the correct logic state for V_{CC} down to +1V. These ICs provide a reset comparator designed to ignore fast transients on V_{CC} . Reset thresholds are available between +2.18V and +4.62V. These small, low-power (4 μ A) devices are ideal for use in portable equipment. All are available in space-saving 3-pin SC70 and SOT23 packages, and are specified from -40°C to +105°C.

Applications

Computers and Controllers
Intelligent Instruments
Set-Top Boxes
Printers
Automotive Systems
Critical μ P and μ C Monitoring
Portable/Battery-Powered Equipment

*Patent pending

Features

- ◆ Precision Monitoring of +2.5V, +3V, +3.3V, and +5V Power-Supply Voltages
- ◆ Available in Four Reset Output Configurations
- ◆ Factory-Set Reset Threshold Voltages: 2.18V, 2.31V, 2.55V, 2.88V, 3.06V, 4.12V, 4.37V, 4.62V
- ◆ $\pm 2.5\%$ Reset Threshold Accuracy Over Temperature
- ◆ Fixed Reset Timeout Period: 100ms (min)
- ◆ Guaranteed $\overline{\text{RESET}}/\overline{\text{RESET}}$ Valid to $V_{CC} = +1V$
- ◆ Debounced Manual Reset Detect (MXD1813/MXD1818)
- ◆ Power-Supply Transient Immunity
- ◆ No External Components
- ◆ Low Power Consumption (4 μ A)
- ◆ Pin Compatible with DS181_ Products (SOT23)
- ◆ 3-Pin SC70 and SOT23 Packages

Ordering Information

PART [†]	TEMP RANGE	PIN-PACKAGE
MXD1810UR_ _-T	-40°C to +105°C	3 SOT23-3
MXD1810XR_ _-T	-40°C to +105°C	3 SC70-3

[†] The MXD1810–MXD1813/MXD1815–MXD1818 are available with factory-set V_{CC} reset thresholds from +2.18V to +3.06V (MXD1815–MXD1818) and +4.12V to +4.62V (MXD1810–MXD1813). Choose the desired reset-threshold suffix from the Reset Threshold Table and insert it in place of the “_ _” following “R” in the part number. All devices are available in tape-and-reel only in 2500 unit increments. Other threshold voltages may be available. Contact factory for availability.

Devices are available in both leaded and lead-free packaging. Specify lead-free by replacing “-T” with “+T” when ordering.

Ordering Information continued at end of data sheet.

Pin Configurations

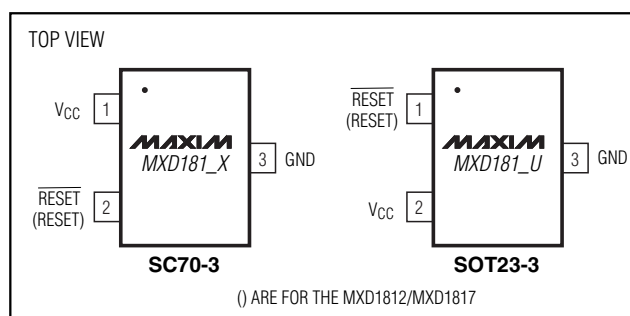

Low-Power μP Reset Circuits in 3-Pin SC70/SOT23

ABSOLUTE MAXIMUM RATINGS

V _{CC} to GND	-0.3V to +6.0V	Output Current ($\overline{\text{RESET}}$, RESET).....	20mA
Push-Pull $\overline{\text{RESET}}$ (MXD1810/MXD1815), RESET (MXD1812/MXD1817) to GND.....	-0.3V to (V _{CC} + 0.3V)	Continuous Power Dissipation (T _A = +70°C)	
Open-Drain $\overline{\text{RESET}}$ (MXD1811/MXD1816) to GND	-0.3V to +6.0V	3-Pin SC70 (derate 2.17mW above +70°C).....	174mW
Open-Drain $\overline{\text{RESET}}$ (MXD1813/MXD1818) to GND	-0.3V to (V _{CC} + 0.3V)	3-Pin SOT23 (derate 4mW/°C above +70°C)	320mW
Input Current (V _{CC} , RESET).....	20mA	Operating Temperature Range	-40°C to +105°C
		Junction Temperature	+150°C
		Storage Temperature Range	-65°C to +150°C
		Lead Temperature (soldering, 10s)	+300°C

Stresses beyond those listed under "Absolute Maximum Ratings" may cause permanent damage to the device. These are stress ratings only, and functional operation of the device at these or any other conditions beyond those indicated in the operational sections of the specifications is not implied. Exposure to absolute maximum rating conditions for extended periods may affect device reliability.

ELECTRICAL CHARACTERISTICS

(V_{CC} = full range, T_A = -40°C to +105°C, unless otherwise specified. Typical values are at T_A = +25°C.) (Note 1)

PARAMETER	SYMBOL	CONDITIONS	MIN	TYP	MAX	UNITS
Supply Voltage Range	V _{CC}	T _A = 0°C to +105°C	1.0		5.5	V
		T _A = -40°C to +105°C	1.2		5.5	
Supply Current	I _{CC}	V _{CC} = +5.5V, V _{CC} > V _{TH} , no load		9	16	μ A
		V _{CC} = +3.6V, V _{CC} > V _{TH} , no load		4	10	
Reset Threshold	V _{TH}	MXD181__R46	4.50	4.62	4.75	V
		MXD181__R44	4.25	4.37	4.49	
		MXD181__R41	4.00	4.12	4.24	
		MXD181__R31	2.98	3.06	3.15	
		MXD181__R29	2.80	2.88	2.97	
		MXD181__R26	2.47	2.55	2.64	
		MXD181__R23	2.25	2.31	2.37	
MXD181__R22	2.12	2.18	2.25			
Active Reset Timeout Period	t _{RP}	V _{CC} rising	100	150	250	ms
V _{CC} to Reset Delay	t _{RD}	V _{CC} = (V _{TH} + 100mV) falling to (V _{TH} - 200mV)		2	5	μ s
		V _{CC} rising, t _R = 5 μ s	100	150	250	ms
Push-Button Detect to Reset	t _{PB}	MXD1813/MXD1818 only	1.5			μ s
Push-Button Reset Timeout Period	t _{PBRST}	MXD1813/MXD1818 only	100	150	250	ms
Input Low Voltage	V _{IL}	MXD1813/MXD1818 only	T _A = +25°C to +105°C		0.34	V
			T _A = -40°C to +25°C		0.15	
Input High Voltage	V _{IH}	MXD1813/MXD1818 only	0.7 × V _{CC}			V
$\overline{\text{RESET}}$ Output Source Current	I _{OH}	V _{CC} ≥ V _{TH} (MAX), reset not asserted, MXD1810/MXD1815		350		μ A
RESET Output Source Current	I _{OH}	V _{CC} ≤ V _{TH} (MIN), reset asserted, MXD1812/MXD1817		350		μ A
$\overline{\text{RESET}}$ Output Sink Current	I _{OL}	V _{CC} ≥ 2.7V, reset asserted, V _{OUT} = 0.4V MXD1810/MXD1811/MXD1813/MXD1815/ MXD1816/MXD1818 (Note 2)	10			mA
RESET Output Sink Current	I _{OL}	V _{CC} ≥ 2.7V, reset not asserted, V _{OUT} = 0.4V MXD1812/MXD1817	10			mA

Low-Power μ P Reset Circuits in 3-Pin SC70/SOT23

MXD1810-MXD1813/MXD1815-MXD1818

ELECTRICAL CHARACTERISTICS (continued)

(V_{CC} = full range, T_A = -40°C to $+105^{\circ}\text{C}$, unless otherwise specified. Typical values are at T_A = $+25^{\circ}\text{C}$.) (Note 1)

PARAMETER	SYMBOL	CONDITIONS	MIN	TYP	MAX	UNITS
Output High Voltage	V_{OH}	$0 < I_{OH} < 500\mu\text{A}$	$V_{CC} - 0.5$	$V_{CC} - 0.1$		V
Output Capacitance (Note 2)	C_{OUT}				10	pF
Internal Pullup Resistor Open-Drain	R_P	MXD1811/MXD1816	3.5	5.5	7.5	k Ω
		MXD1813/MXD1818	3.1	5.5	7.5	

Note 1: Production testing done at T_A = $+25^{\circ}\text{C}$; limits over temperature guaranteed by design.

Note 2: The MXD1811/MXD1813/MXD1816/MXD1818 have an internal pullup resistor which may deliver 1mA of sink current.

Note 3: Guaranteed by design.

Typical Operating Characteristics

(T_A = $+25^{\circ}\text{C}$, unless otherwise noted.)

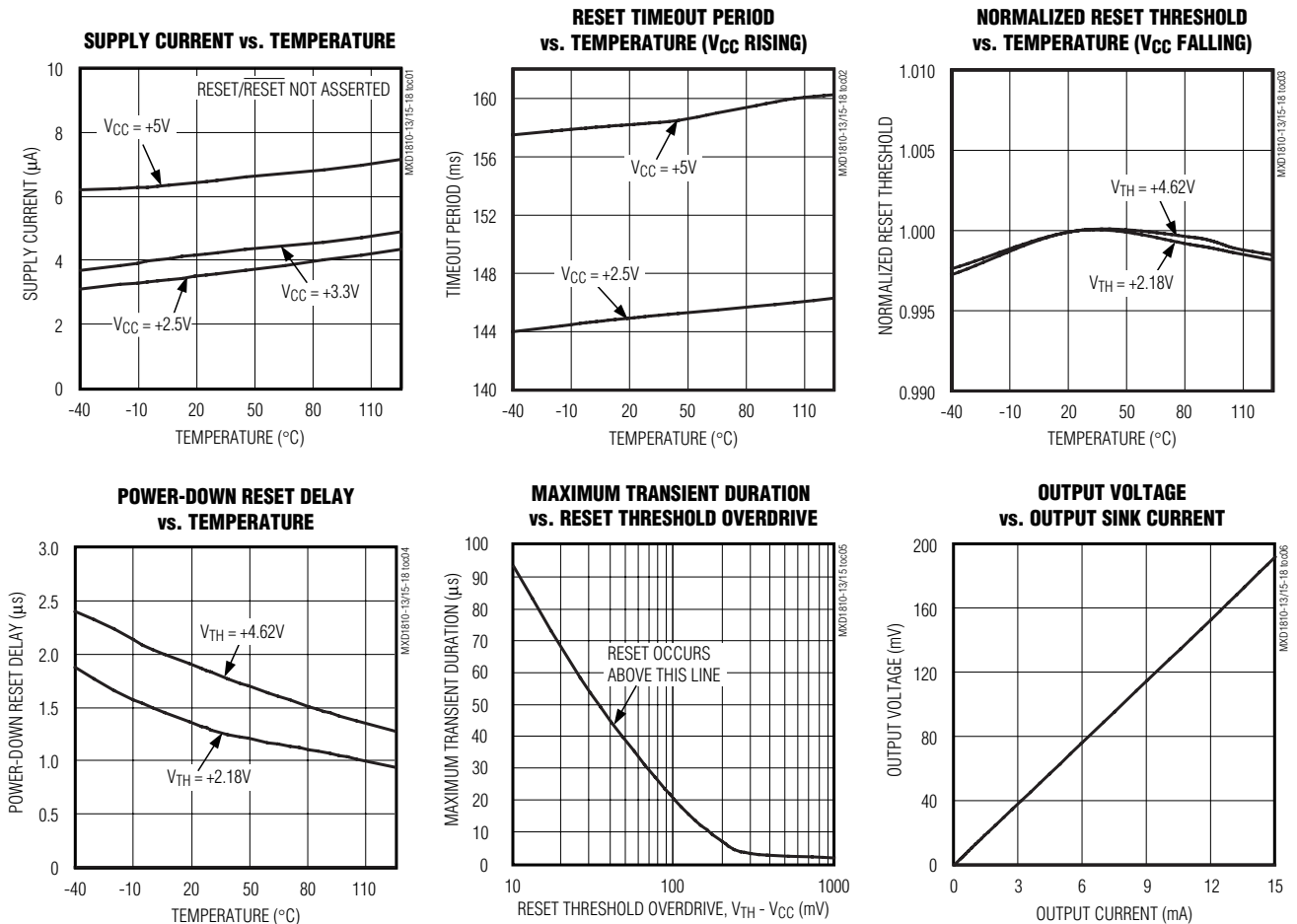

Low-Power μP Reset Circuits in 3-Pin SC70/SOT23

Typical Operating Characteristics (continued)

($T_A = +25^\circ C$, unless otherwise noted.)

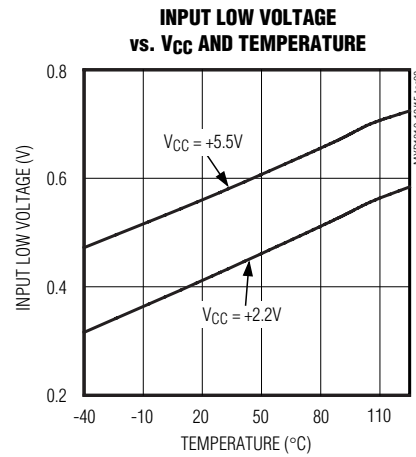
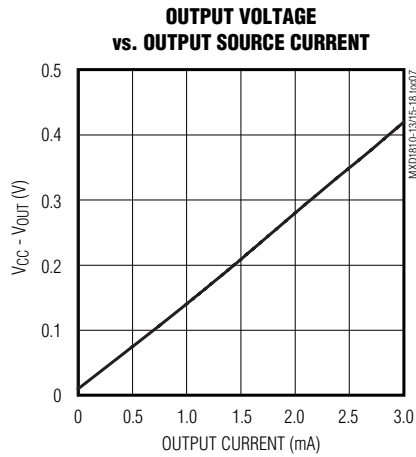

Pin Descriptions

MXD1810/MXD1815

PIN		NAME	FUNCTION
SC70	SOT23		
2	1	\overline{RESET}	Push-Pull, Active-Low Reset Output. \overline{RESET} changes from high to low when V_{CC} drops below the selected reset threshold. \overline{RESET} remains low for the reset timeout period after V_{CC} exceeds the device reset threshold.
1	2	V_{CC}	Supply Voltage and Input for Reset Threshold Monitor
3	3	GND	Ground

MXD1811/MXD1816

PIN		NAME	FUNCTION
SC70	SOT23		
2	1	\overline{RESET}	Open-Drain, Active-Low Reset Output. \overline{RESET} changes from high to low when V_{CC} drops below the selected reset threshold. \overline{RESET} remains low for the reset timeout period after V_{CC} exceeds the device reset threshold. \overline{RESET} has an internal $5.5k\Omega$ pullup resistor.
1	2	V_{CC}	Supply Voltage and Input for Reset Threshold Monitor
3	3	GND	Ground

Low-Power μ P Reset Circuits in 3-Pin SC70/SOT23

Pin Descriptions (continued)

MXD1812/MXD1817

PIN		NAME	FUNCTION
SC70	SOT23		
2	1	RESET	Push-Pull, Active-High Reset Output. RESET changes from low to high when V _{CC} drops below the selected reset threshold. RESET remains high for the reset timeout period after V _{CC} exceeds the device reset threshold.
1	2	V _{CC}	Supply Voltage and Input for Reset Threshold Monitor
3	3	GND	Ground

MXD1813/MXD1818

PIN		NAME	FUNCTION
SC70	SOT23		
2	1	$\overline{\text{RESET}}$	Open-Drain, Active-Low Reset Output with Manual Reset Detect. $\overline{\text{RESET}}$ changes from high to low when V _{CC} drops below the selected reset threshold, or $\overline{\text{RESET}}$ is externally pulled low for at least 1.5 μ s. $\overline{\text{RESET}}$ remains low for the reset timeout period after V _{CC} exceeds the device reset threshold or after the external manual reset is released. $\overline{\text{RESET}}$ has an internal 5.5k Ω pullup resistor.
1	2	V _{CC}	Supply Voltage and Input for Reset Threshold Monitor
3	3	GND	Ground

Detailed Description

RESET/RESET Output

A microprocessor's (μ P's) reset input starts the microprocessor in a known state. The MXD1810–MXD1813/MXD1815–MXD1818 μ P supervisory circuits assert reset to prevent code-execution errors during power-up, power-down, and brownout conditions (Figure 4). Whenever V_{CC} falls below the reset threshold, the reset output asserts. Once V_{CC} exceeds the reset threshold, an internal timer keeps the reset output asserted for the specified reset timeout period (t_{RP}). Reset is also triggered by an externally initiated rising edge on the $\overline{\text{RESET}}$ pin (MXD1813/MXD1818), following a low signal of 1.5 μ s minimum duration.

Push-Button Reset (MXD1813/MXD1818)

Many μ P-based products require push-button reset capability (Figure 5), allowing the operator, a test technician, or external logic circuitry to initiate reset. On the MXD1813/MXD1818, a logic-low on $\overline{\text{RESET}}$ held for greater than 1.5 μ s asserts a reset. $\overline{\text{RESET}}$ deasserts following a 100ms minimum reset timeout delay

(t_{PBRST}). A manual reset input shorter than 1.5 μ s may release $\overline{\text{RESET}}$ without the 100ms minimum reset timeout delay. To facilitate use with mechanical switches, the MXD1813/MXD1818 contain internal debouncing circuitry. A debounced waveform is shown in Figure 6.

Applications Information

Interfacing to μ Ps with Bidirectional Reset Pins

Since the $\overline{\text{RESET}}$ output on the MXD1811/MXD1816 is open drain, these devices interface easily with μ Ps that have bidirectional reset pins, such as the Motorola 68HC11. Connecting the μ P supervisor's $\overline{\text{RESET}}$ output directly to the microcontroller's (μ C's) RESET pin allows either device to assert reset (Figure 7). No external pullup resistor is required, as it is contained within the MXD1811/MXD1816.

Negative-Going V_{CC} Transients

In addition to issuing a reset to the μ P during power-up, power-down, and brownout conditions, these devices are relatively immune to short-duration, negative-going V_{CC} transients (glitches).

Low-Power μP Reset Circuits in 3-Pin SC70/SOT23

Functional Diagram

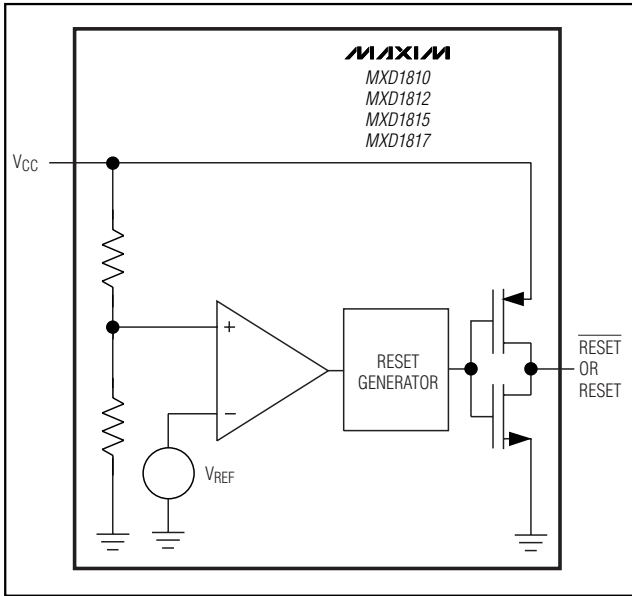

Figure 1. Functional Diagram, Push-Pull Output

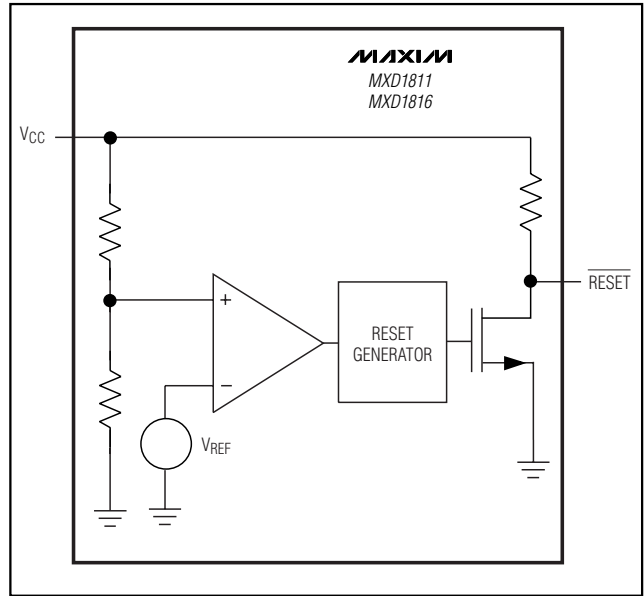

Figure 2. Functional Diagram, Open-Drain Active-Low Output

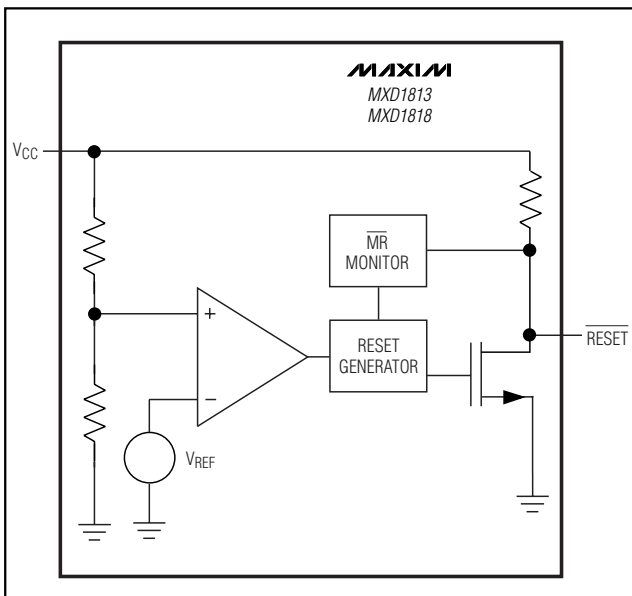

Figure 3. Functional Diagram, Open-Drain Active-Low Output with Manual Reset Detection

The *Typical Operating Characteristics* show the Maximum Transient Duration vs. Reset Threshold Overdrive for which reset pulses are **not** generated. The graph shows the maximum pulse width that a negative-going V_{CC} transient may typically have without issuing a reset signal. As the amplitude of the transient increases, the maximum allowable pulse width decreases.

Ensuring a Valid Reset Output Down to $V_{CC} = 0$

When V_{CC} falls below the minimum operating voltage, push-pull structured reset sinking (or sourcing) capabilities decrease dramatically. High-impedance CMOS logic inputs connected to the $\overline{\text{RESET}}$ / $\overline{\text{RESET}}$ pin can drift to indeterminate voltages. This does not present a problem in most cases, since most μP s and circuitry do not operate at V_{CC} below +1V. For MXD1810/MXD1815 applications where $\overline{\text{RESET}}$ must be valid down to $V_{CC} = 0$, adding a pulldown resistor between $\overline{\text{RESET}}$ and GND removes stray leakage currents, holding $\overline{\text{RESET}}$ low (Figure 8). The pulldown resistor value is not critical; 100k Ω is large enough not to load $\overline{\text{RESET}}$ and small enough to pull $\overline{\text{RESET}}$ low. For MXD1812/

Low-Power μ P Reset Circuits in 3-Pin SC70/SOT23

MXD1810-MXD1813/MXD1815-MXD1818

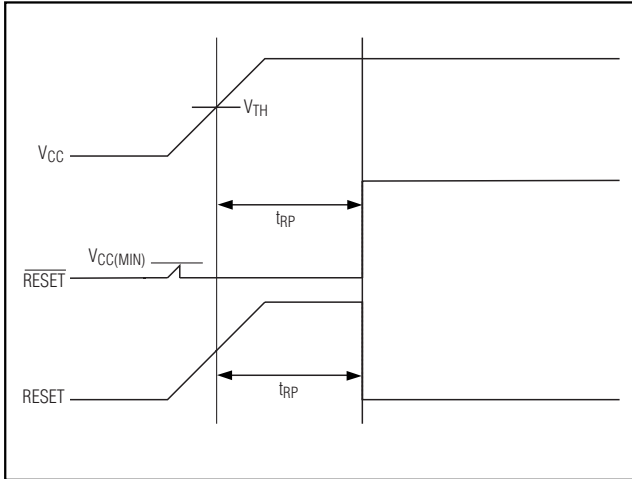

Figure 4. Power-Up Reset Timing Diagram

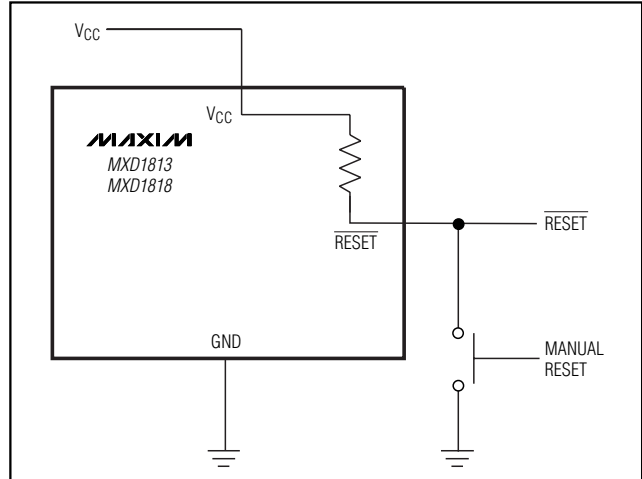

Figure 5. Push-Button Manual Reset

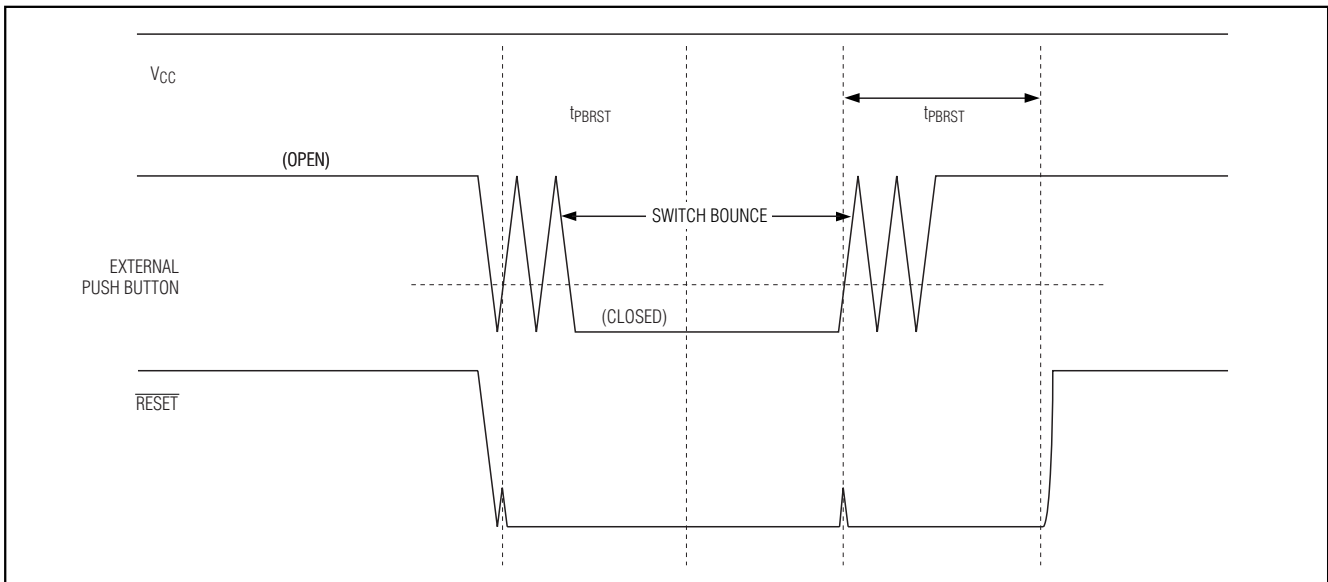

Figure 6. Manual Reset Timing Diagram

MXD1817 applications where RESET must be valid to $V_{CC} = 0$, a $100k\Omega$ pullup resistor between RESET and V_{CC} holds RESET high when V_{CC} falls below the minimum operating voltage (Figure 9).

The MXD1811/MXD1813/MXD1816/MXD1818 have open-drain, active-low outputs with a pullup resistor included internal to the devices. While using these devices RESET will most likely not maintain an active

condition when the supply voltage drops below the minimum V_{CC} , but will drift to a nonactive level due to the pullup resistor and the reduced sinking capability of the open-drain output. Therefore, these devices are not recommended for applications where the RESET pin is required to be valid at $V_{CC} = 0$.

Low-Power μP Reset Circuits in 3-Pin SC70/SOT23

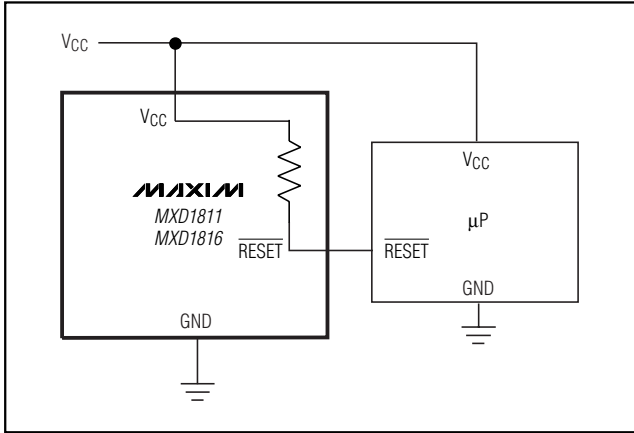

Figure 7. Interfacing to Microprocessors with Bidirectional Reset Pins

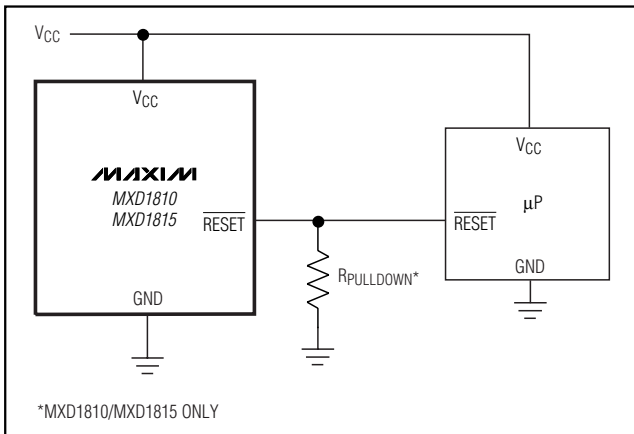

Figure 8. Ensuring Valid \overline{RESET} Output Down to $V_{CC} = 0$ (MXD1810/MXD1815 only)

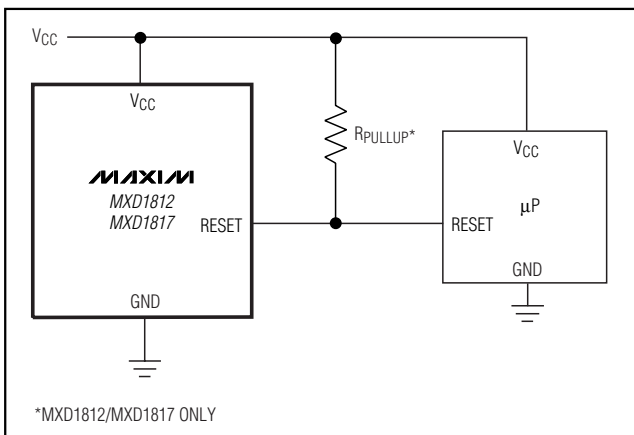

Figure 9. Ensuring Valid \overline{RESET} Output Down to $V_{CC} = 0$ (MXD1812/MXD1817 only)

Table 1. Device Marking Codes

PART	TOP MARK	
	SOT23	SC70
MXD1810_R46	FZIV	AEK
MXD1810_R44	FZKD	AHU
MXD1810_R41	FZKC	AHT
MXD1811_R46	FZKF	AHW
MXD1811_R44	FZIW	AEL
MXD1811_R41	FZKE	AHV
MXD1812_R46	FZKH	AHY
MXD1812_R44	FZKG	AHX
MXD1812_R41	FZIX	AEM
MXD1813_R46	FZII	AEN
MXD1813_R44	FZKJ	AIA
MXD1813_R41	FZKI	AHZ
MXD1815_R31	FZKN	AIE
MXD1815_R29	FZIZ	AEO
MXD1815_R26	FZKM	AID
MXD1815_R23	FZKL	AIC
MXD1815_R22	FZKK	AIB
MXD1816_R31	FZKR	AIL
MXD1816_R29	FZKQ	AIH
MXD1816_R26	FZKP	AIG
MXD1816_R23	FZKO	AIF
MXD1816_R22	FZJA	AEP
MXD1817_R31	FZJB	AEQ
MXD1817_R29	FZKV	AIM
MXD1817_R26	FZKU	AIL
MXD1817_R23	FZKT	AIK
MXD1817_R22	FZKS	AIJ
MXD1818_R31	FZKY	AIP
MXD1818_R29	FZKX	AIO
MXD1818_R26	FZJC	AER
MXD1818_R23	FZKW	AIN
MXD1818_R22	FZJE	AEV

Low-Power μ P Reset Circuits in 3-Pin SC70/SOT23

Selector Guide

PART	5V SYSTEMS	2.5V/3.0V/3.3V SYSTEMS	PUSH-PULL RESET	OPEN-DRAIN RESET	PUSH-PULL RESET	OPEN-DRAIN RESET WITH PUSH-BUTTON DETECT
MXD1810	✓	—	✓	—	—	—
MXD1811	✓	—	—	✓	—	—
MXD1812	✓	—	—	—	✓	—
MXD1813	✓	—	—	—	—	✓
MXD1815	—	✓	✓	—	—	—
MXD1816	—	✓	—	✓	—	—
MXD1817	—	✓	—	—	✓	—
MXD1818	—	✓	—	—	—	✓

MXD1810-MXD1813/MXD1815-MXD1818

Ordering Information (continued)

PART [†]	TEMP RANGE	PIN-PACKAGE
MXD1811UR__-T	-40°C to +105°C	3 SOT23-3
MXD1811XR__-T	-40°C to +105°C	3 SC70-3
MXD1812UR__-T	-40°C to +105°C	3 SOT23-3
MXD1812XR__-T	-40°C to +105°C	3 SC70-3
MXD1813UR__-T	-40°C to +105°C	3 SOT23-3
MXD1813XR__-T	-40°C to +105°C	3 SC70-3
MXD1815UR__-T	-40°C to +105°C	3 SOT23-3
MXD1815XR__-T	-40°C to +105°C	3 SC70-3
MXD1816UR__-T	-40°C to +105°C	3 SOT23-3
MXD1816XR__-T	-40°C to +105°C	3 SC70-3
MXD1817UR__-T	-40°C to +105°C	3 SOT23-3
MXD1817XR__-T	-40°C to +105°C	3 SC70-3
MXD1818UR__-T	-40°C to +105°C	3 SOT23-3
MXD1818XR__-T	-40°C to +105°C	3 SC70-3

[†]The MXD1810-MXD1813/MXD1815-MXD1818 are available with factory-set V_{CC} reset thresholds from +2.18V to +3.06V (MXD1815-MXD1818) and +4.12V to +4.62V (MXD1810-MXD1813). Choose the desired reset-threshold suffix from the Reset Threshold Table and insert it in place of the “__” following “R” in the part number. All devices are available in tape-and-reel only in 2500 unit increments. Other threshold voltages may be available. Contact factory for availability.

Devices are available in both leaded and lead-free packaging. Specify lead-free by replacing “-T” with “+T” when ordering.

Reset Threshold Table

PART	SUFFIX (__)	TYP. RESET THRESHOLD (V)*
MXD1810-MXD1813	46	4.62
MXD1810-MXD1813	44	4.37
MXD1810-MXD1813	41	4.12
MXD1815-MXD1818	31	3.06
MXD1815-MXD1818	29	2.88
MXD1815-MXD1818	26	2.55
MXD1815-MXD1818	23	2.31
MXD1815-MXD1818	22	2.18

*Factory-trimmed reset thresholds are nominally $\pm 1.5\%$ at room temperature.

Chip Information

TRANSISTOR COUNT: 709

PROCESS TECHNOLOGY: BiCMOS

Low-Power μ P Reset Circuits in 3-Pin SC70/SOT23

Package Information

(The package drawing(s) in this data sheet may not reflect the most current specifications. For the latest package outline information go to www.maxim-ic.com/packages.)

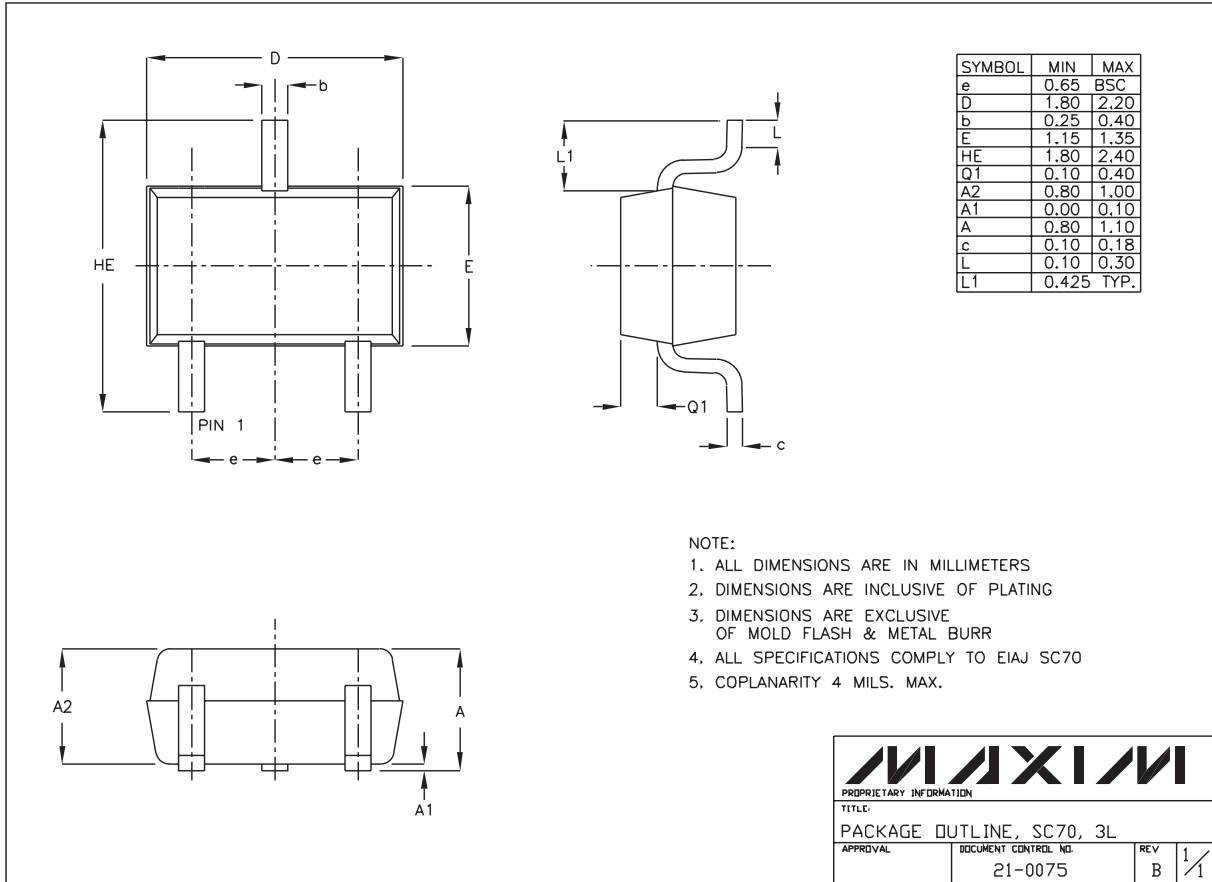

SC70, 3LEPS

Low-Power μP Reset Circuits in 3-Pin SC70/SOT23

Package Information (continued)

(The package drawing(s) in this data sheet may not reflect the most current specifications. For the latest package outline information go to www.maxim-ic.com/packages.)

NOTES:

1. D&E DO NOT INCLUDE MOLD FLASH.
2. MOLD FLASH OR PROTRUSIONS NOT TO EXCEED .15mm (.006")
3. CONTROLLING DIMENSION: MILLIMETER

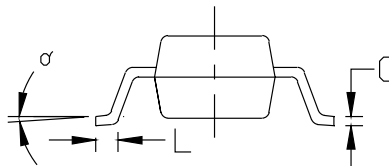
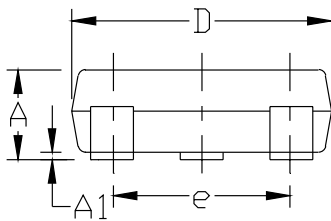
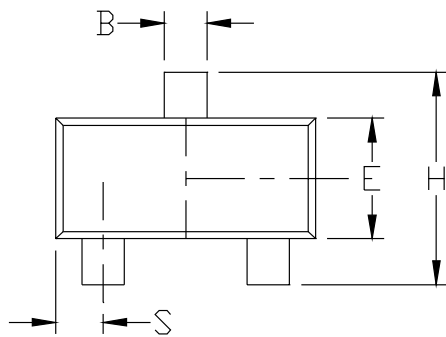

DIM	INCHES		MILLIMETERS	
	MIN	MAX	MIN	MAX
A	0.031	0.047	0.787	1.194
A1	0.001	0.005	0.025	0.127
B	0.014	0.022	0.356	0.559
C	0.0034	0.006	0.086	0.152
D	0.105	0.120	2.667	3.048
E	0.047	0.055	1.194	1.397
e	0.070	0.080	1.778	2.032
H	0.082	0.098	2.083	2.489
L	0.004	0.012	0.102	0.305
S	0.017	0.022	0.432	0.559
α	0°	8°	0°	8°

MAXIM			
<small>PROPRIETARY INFORMATION</small>			
<small>TITLE:</small>			
PACKAGE OUTLINE, SOT-23, 3L			
<small>APPROVAL</small>	<small>DOCUMENT CONTROL NO.</small>	<small>REV</small>	<small>1/1</small>
	21-0051	C	

Revision History

Pages changed at Rev 1: 1, 9, 10, 11

MXD1810-MXD1813/MXD1815-MXD1818

Maxim cannot assume responsibility for use of any circuitry other than circuitry entirely embodied in a Maxim product. No circuit patent licenses are implied. Maxim reserves the right to change the circuitry and specifications without notice at any time.

Maxim Integrated Products, 120 San Gabriel Drive, Sunnyvale, CA 94086 408-737-7600 11