



16-Bit, RISC, Microcontroller-Based, Ultrasonic Distance-Measuring System

MAXQ7667

General Description

The MAXQ7667 smart system-on-a-chip (SoC) provides a time-of-flight ultrasonic distance-measuring solution. The device is optimized for applications involving large distance measurement with weak input signals or multiple target identification. The MAXQ7667 features high signal-to-noise ratio achieved by combining flexible electronics with the intelligence necessary to optimize each function as environmental and target conditions change.

An integrated burst signal generator and echo reception components process ultrasonic signals between 25kHz and 100kHz. Echo reception components include a programmable gain low-noise amplifier (LNA), a 16-bit sigma-delta ADC to digitize the received echo signals, and digital signal processing (DSP). DSP limits noise with a bandpass filter, and creates an echo envelope through demodulation and lowpass filtering. Input referred noise is a low 0.7 μ V_{RMS}. A programmable phase-locked loop (PLL) frequency synthesizer supplies the reference frequency for the burst generator and the clock for the echo receiver's digital filter. An embedded 16-bit MAXQ20 microcontroller (μ C) controls all the preceding functions.

The μ C optimizes the burst frequency and reception frequency for each transmission at any temperature. The MAXQ7667 achieves smart sensing by monitoring the echo signals and then actively changing the transmitted and received parameters to obtain optimum results. Digital filtering and burst synthesis do not require CPU intervention. This leaves all the CPU power available for echo optimization, communication, diagnostics, and additional signal processing.

The MAXQ7667 operates with three different power supply voltages: +5V, +3.3V, and +2.5V. Two internal linear regulators allow operation from a single +5V supply when three external power supplies are not available. Alternatively, the MAXQ7667 can control an external pass transistor to allow operation from a single supply voltage of +8V to +65V or more, depending on the external component tolerance. The device is available in a 48-pin LQFP package and is specified to operate from -40°C to +125°C.

Applications

| | |
|-----------------------|------------------|
| Automotive Parking | Automation |
| Vehicle Security | Handheld Devices |
| Industrial Processing | |

Note: Some revisions of this device may incorporate deviations from published specifications known as errata. Multiple revisions of any device may be simultaneously available through various sales channels. For information about device errata, go to: www.maxim-ic.com/errata.



For pricing, delivery, and ordering information, please contact Maxim Direct at 1-888-629-4642, or visit Maxim's website at www.maxim-ic.com.

Features

- ◆ Smart Analog Peripherals
 - Dedicated Ultrasonic Burst Generator
 - Echo Receiving Path (Includes LNA, Sigma-Delta ADC)
 - 5-Channel, 12-Bit SAR ADC with 250ksps Sampling Rate
 - Internal Bandgap Voltage Reference for the ADCs (Also Accepts External Voltage Reference)
- ◆ Timer/Digital I/O Peripherals
- ◆ High-Performance, Low-Power, 16-Bit RISC Core
- ◆ Program and Data Memory
- ◆ Crystal/Clock Module
- ◆ 16 x 16 Hardware Multiplier with 48-Bit Accumulator, Single Clock Cycle
- ◆ Power-Management Module
- ◆ JTAG Interface
- ◆ Universal Asynchronous Receiver-Transmitter (UART)
- ◆ Local Interconnect Network (LIN)

See the Detailed Features section for complete list of features.

Ordering Information

| PART | PIN-PACKAGE | RAM (KB) | FLASH (KB) |
|-----------------|-------------|----------|------------|
| MAXQ7667AACM/V+ | 48 LQFP | 4 | 32 |

Note: All devices are specified over the -40°C to +125°C operating temperature range.

V denotes an automotive qualified part.

+Denotes a lead(Pb)-free/RoHS-compliant package.

Pin Configuration appears at end of data sheet.

16-Bit, RISC, Microcontroller-Based, Ultrasonic Distance-Measuring System

ABSOLUTE MAXIMUM RATINGS

| | | | |
|---|---------------------------------------|---|-------------------------------------|
| DVDDIO, GATE5, REG3P3, REG2P5 to DGND | -0.3V to +6.0V | Analog Inputs/Outputs to AGND | -0.3V to (V _{AVDD} + 0.3V) |
| AVDD to AGND | -0.3V to +4.0V | XIN, XOUT to DGND | -0.3V to (V _{DVDD} + 0.3V) |
| DVDD to DGND | -0.3V to +3.0V | Maximum Current into Any Pin..... | 50mA |
| DVDDIO to DVDD | -0.3V to +6.0V | Continuous Power Dissipation (T _A = +70°C) | |
| AVDD to DVDD | -0.3V to +4.0V | 48-Pin LQFP (derate 21.7mW/°C above +70°C)..... | 1739.1mW |
| AGND to DGND | -0.3V to +0.3V | Operating Temperature Range | -40°C to +125°C |
| Digital Inputs/Outputs to DGND..... | -0.3V to (V _{DVDDIO} + 0.3V) | Storage Temperature Range | -60°C to +150°C |
| | | Lead Temperature (soldering, 10s) | +300°C |

Stresses beyond those listed under "Absolute Maximum Ratings" may cause permanent damage to the device. These are stress ratings only, and functional operation of the device at these or any other conditions beyond those indicated in the operational sections of the specifications is not implied. Exposure to absolute maximum rating conditions for extended periods may affect device reliability.

ELECTRICAL CHARACTERISTICS

(V_{DVDDIO} = +5V, V_{AVDD} = +3.3V; V_{DVDD} = +2.5V, system clock (f_{SYCLK}) = 16MHz, burst frequency (f_{BURST}) = bandpass frequency (f_{BPF}) = 50kHz, C_{REFBG} = C_{REF} = 1μF in parallel with 0.01μF, f_{ADCCLK} = 2MHz (SAR data rate = 125ksps), T_A = T_{MIN} to T_{MAX}, unless otherwise specified. Typical values are at T_A = +25°C.)

| PARAMETER | SYMBOL | CONDITIONS | MIN | TYP | MAX | UNITS |
|---|-----------------|--|---------------------------------|-----------------------|-----|-------------------|
| ECHO INPUT (Low-Noise Amplifier and Sigma-Delta ADC) | | | | | | |
| Input-Referred Noise (Note 1) | | VGA gain adjust = 1.55μVp.p/LSB | | 5.6 | | μV _{RMS} |
| | | VGA gain adjust = 0.1μVp.p/LSB | | 0.7 | | |
| Minimum Detectable Signal | | VGA gain adjust = 1.55μVp.p/LSB | | 80 | | μVp.p |
| | | VGA gain adjust = 0.1μVp.p/LSB | | 10 | | |
| Operating Input Range | | VGA gain adjust = 1.55μVp.p/LSB, unclipped | | 100 | | mVp.p |
| | | VGA gain adjust = 0.1μVp.p/LSB, unclipped | | 6.7 | | |
| Programmable Gain | | From echo input to bandpass filter in reply to input | VGA gain adjust = 1.55μVp.p/LSB | 1.55 | | μVp.p/LSB |
| | | | VGA gain adjust = 0.1μVp.p/LSB | 0.1 | | |
| Programmable-Gain Adjust Resolution | | (Note 2) | | 10 | | % |
| LNA Bandwidth | | | | 150 | | kHz |
| ADC Sampling Rate | | | | 80 x f _{BPF} | | kHz |
| ADC Output Data Rate | | | | 10 x f _{BPF} | | kHz |
| ADC Output Data Resolution | | | | 16 | | Bits |
| Echo-Input Resistance | R _{IN} | For each echo input | | 14 | | kΩ |
| Echo-Input Capacitance | | | | 14 | | pF |
| Echo-Input DC Bias Voltage | | | | V _{AVDD} /2 | | V |
| Maximum Overvoltage Recovery Time | | Recover from 2Vp.p input | | 10 | | μs |

16-Bit, RISC, Microcontroller-Based, Ultrasonic Distance-Measuring System

MAX97667

ELECTRICAL CHARACTERISTICS (continued)

($V_{DVDDIO} = +5V$, $V_{AVDD} = +3.3V$; $V_{DVDD} = +2.5V$, system clock (f_{SYSCLK}) = 16MHz, burst frequency (f_{BURST}) = bandpass frequency (f_{BPF}) = 50kHz, $C_{REFBG} = C_{REF} = 1\mu F$ in parallel with $0.01\mu F$, $f_{ADCCLK} = 2MHz$ (SAR data rate = 125ksps), $T_A = T_{MIN}$ to T_{MAX} , unless otherwise specified. Typical values are at $T_A = +25^\circ C$.)

| PARAMETER | SYMBOL | CONDITIONS | MIN | TYP | MAX | UNITS |
|------------------------------------|--------------|---|--------------|-----------------------|--------------|-------------------|
| BANDPASS FILTER | | | | | | |
| Center Frequency | f_{BPF} | | 25 | | 100 | kHz |
| Passband Width | | -3dB | | $0.14 \times f_{BPF}$ | | kHz |
| Minimum Stopband Rejection | | One decade away from center frequency | | -60 | | dB |
| Output Data Rate | | | | $10 \times f_{BPF}$ | | ksps |
| Output Data Resolution | | | | 16 | | Bits |
| LOWPASS FILTER | | | | | | |
| Corner Frequency | f_{LPF} | -3dB | | $0.1 \times f_{BPF}$ | | kHz |
| Rolloff | | | | 40 | | dB/Decade |
| Output Data Rate | | | | $5 \times f_{BPF}$ | | ksps |
| Output Data Resolution | | | | 16 | | Bits |
| SAR ADC | | | | | | |
| Resolution | | Measurement | 12 | | | Bits |
| | | No missing codes | 11 | | | |
| Integral Nonlinearity | | Tested at 125ksps | | ± 1 | ± 2 | LSB |
| Differential Nonlinearity | | Tested at 125ksps | -2 | | +2 | LSB |
| Offset Error | | | | ± 1 | ± 3 | mV |
| Offset-Error Drift | | | | ± 5 | | $\mu V/^\circ C$ |
| Gain Error | | | | | ± 1 | % |
| Gain-Error Temperature Coefficient | | | | ± 0.4 | | ppmFS/ $^\circ C$ |
| Input-Referred Noise | | At ADC inputs | | 400 | | μV_{RMS} |
| Differential Input Range | | Unipolar | 0 | | V_{REF} | V |
| | | Bipolar | $-V_{REF}/2$ | | $+V_{REF}/2$ | |
| Absolute Input Range | | | 0 | | V_{AVDD} | V |
| Input Leakage Current | | | | ± 0.1 | | μA |
| Conversion Time | | 13 ADCCLK cycles at 2MHz | | | 6.5 | μs |
| Input Capacitance | | | | 14 | | pF |
| Track-and-Hold Acquisition Time | | Three ADCCLK cycles at 2MHz | | | 1.5 | μs |
| Turn-On Time | | Eight ADCCLK cycles at 2MHz | | | 4 | μs |
| Conversion Clock | f_{ADCCLK} | | 0.5 | | 4 | MHz |
| Conversion Rate | | $f_{ADCCLK} = 4MHz$ (not production tested) | | | 250 | ksps |

16-Bit, RISC, Microcontroller-Based, Ultrasonic Distance-Measuring System

ELECTRICAL CHARACTERISTICS (continued)

($V_{DDIO} = +5V$, $V_{AVDD} = +3.3V$; $V_{DVDD} = +2.5V$, system clock (f_{SYSCLK}) = 16MHz, burst frequency (f_{BURST}) = bandpass frequency (f_{BPF}) = 50kHz, $C_{REFBG} = C_{REF} = 1\mu F$ in parallel with $0.01\mu F$, $f_{ADCCLK} = 2MHz$ (SAR data rate = 125ksps), $T_A = T_{MIN}$ to T_{MAX} , unless otherwise specified. Typical values are at $T_A = +25^\circ C$.)

| PARAMETER | SYMBOL | CONDITIONS | MIN | TYP | MAX | UNITS |
|---|--------|--|-----------------------|------|-----------------------|-------------------|
| REFERENCE BUFFER | | | | | | |
| Offset | | | | 5 | | mV |
| Minimum Load | | | 2.5 | | | k Ω |
| Output Bypass Capacitor | | | | 0.47 | | μF |
| EXTERNAL VOLTAGE REFERENCE (Reference Buffer Disabled) | | | | | | |
| Reference Input Range | | Applied at REF | 1.0 | | V_{AVDD} | V |
| Reference Input Impedance | | Measured at REF with the SAR and sigma-delta ADCs running at maximum frequency | | 50 | | k Ω |
| INTERNAL VOLTAGE REFERENCE (REFBG) | | | | | | |
| Initial Accuracy | | | 2.45 | 2.5 | 2.55 | V |
| Maximum Temperature Coefficient | | | | 100 | | ppm/ $^\circ C$ |
| Output Impedance | | | | 1.1 | | k Ω |
| Power-Supply Rejection Ratio | | $V_{AVDD} = 3.0V$ to $3.6V$ | | 60 | | dB |
| Output Noise | | | | 0.5 | | mV _{RMS} |
| PROGRAMMABLE BURST-FREQUENCY OSCILLATOR | | | | | | |
| Burst-Frequency Range | | | 0.025 | | 1.335 | MHz |
| Burst-Frequency Resolution | | | | 0.1 | | % |
| Burst-Frequency Locking Time | | Change from 40kHz to 60kHz | | 5 | | ms |
| | | Change from 50kHz to 50.5kHz | | 2 | | |
| CRYSTAL OSCILLATOR | | | | | | |
| Frequency Range | | Tested crystal frequency | | 16 | | MHz |
| | | Minimum crystal frequency | | 4 | | |
| | | External clock input | 4 | | 16 | |
| Temperature Stability | | Excluding crystal | | 25 | | ppm/ $^\circ C$ |
| Startup Time | | 16MHz crystal | | 10 | | ms |
| XIN Input Low Voltage | | When driven with external clock source | | | $0.3 \times V_{DVDD}$ | V |
| XIN Input High Voltage | | When driven with external clock source | $0.7 \times V_{DVDD}$ | | | V |
| INTERNAL RC OSCILLATOR | | | | | | |
| Frequency | | | | 13.5 | | MHz |
| Initial Accuracy | | | | 10.5 | | % |
| Temperature Drift | | $T_A = T_{MIN}$ to T_{MAX} | | 700 | | ppm |
| Supply Rejection | | $V_{DVDD} = 2.25V$ to $2.75V$ | | -1.5 | | % |

16-Bit, RISC, Microcontroller-Based, Ultrasonic Distance-Measuring System

MAXQ7667

ELECTRICAL CHARACTERISTICS (continued)

($V_{DVDDIO} = +5V$, $V_{AVDD} = +3.3V$; $V_{DVDD} = +2.5V$, system clock (f_{SYSCLK}) = 16MHz, burst frequency (f_{BURST}) = bandpass frequency (f_{BPF}) = 50kHz, $C_{REFBG} = C_{REF} = 1\mu F$ in parallel with $0.01\mu F$, $f_{ADCCLK} = 2MHz$ (SAR data rate = 125ksps), $T_A = T_{MIN}$ to T_{MAX} , unless otherwise specified. Typical values are at $T_A = +25^\circ C$.)

| PARAMETER | SYMBOL | CONDITIONS | MIN | TYP | MAX | UNITS |
|---|--------|--|--------------------|------|------|----------|
| Adjustable Frequency Range | | Using the RCTRM register | -40 | | +40 | % |
| Frequency Adjustment Resolution | | | | 0.2 | | % |
| SUPPLY VOLTAGE SUPERVISORS | | | | | | |
| DVDD Reset Threshold | | Asserts \overline{RESET} if V_{DVDD} falls below this threshold | 2.10 | | 2.25 | V |
| DVDD Interrupt Threshold | | Generates an interrupt if V_{DVDD} falls below this threshold | 2.25 | | 2.38 | V |
| Minimum Reset and Interrupt Threshold Difference | | | 150 | | | mV |
| AVDD Interrupt Threshold | | Generates an interrupt if V_{AVDD} falls below this threshold | 2.95 | | 3.15 | V |
| DVDDIO Interrupt Threshold | | Generates an interrupt if V_{DVDDIO} falls below this threshold | 4.5 | | 4.75 | V |
| Supervisor Operating Range | | At DVDD | 1.5 | | 2.75 | V |
| Supervisor Hysteresis | | | | 1 | | % |
| \overline{RESET} Release Delay | | After V_{DVDD} rises above the reset threshold | | 35 | | μs |
| Power-Up Time | | Time from \overline{RESET} is released to the execution of the first instruction (serial bootloader off) | | 1 | | μs |
| +5V LINEAR REGULATOR (DVDDIO, GATE5, Requires External Pass Transistor, see the <i>Typical Application Circuit/Functional Diagram</i>) | | | | | | |
| Regulator Output Voltage | | At DVDDIO | 4.75 | | 5.25 | V |
| GATE5 Output High Voltage | | $I_{SOURCE} = 0\mu A$ (no load) | $V_{DVDDIO} - 0.1$ | | | V |
| GATE5 Output Low Voltage | | $I_{SINK} = 500\mu A$ | | | 2 | V |
| GATE5 Output Resistance | | $I_{SINK} = 0\mu A$ to $50\mu A$ | | 330 | | Ω |
| Gain Bandwidth | | DVDDIO to GATE5 | | 1.58 | | kHz |
| Gain | | DVDDIO to GATE5 | | 1700 | | V/V |
| GATE5 Slew Rate | | | | 4.3 | | V/ms |
| Maximum Load Capacitance | | Maximum capacitance on DVDDIO when using an external pass transistor | | 1 | | μF |
| +3.3V LINEAR REGULATOR (REG3P3) | | | | | | |
| REG3P3 Output Voltage | | | 3.15 | | 3.45 | V |
| Load Current | | | | | 50 | mA |
| Output Short-Circuit Current | | REG3P3 shorted to AGND | | 150 | | mA |

16-Bit, RISC, Microcontroller-Based, Ultrasonic Distance-Measuring System

ELECTRICAL CHARACTERISTICS (continued)

($V_{DVDDIO} = +5V$, $V_{AVDD} = +3.3V$; $V_{DVDD} = +2.5V$, system clock (f_{SYSCLK}) = 16MHz, burst frequency (f_{BURST}) = bandpass frequency (f_{BPF}) = 50kHz, $C_{REFBG} = C_{REF} = 1\mu F$ in parallel with $0.01\mu F$, $f_{ADCCLK} = 2MHz$ (SAR data rate = 125ksps), $T_A = T_{MIN}$ to T_{MAX} , unless otherwise specified. Typical values are at $T_A = +25^\circ C$.)

| PARAMETER | SYMBOL | CONDITIONS | MIN | TYP | MAX | UNITS |
|--|--------------------------------|--|---------------------------------------|------------|---------|------------|
| +2.5V LINEAR REGULATOR (REG2P5) | | | | | | |
| REG2P5 Output Voltage | | | 2.38 | | 2.62 | V |
| Load Current | | | | | 50 | mA |
| Output Short-Circuit Current | | REG2P5 shorted to DGND | | 100 | | mA |
| POWER REQUIREMENTS | | | | | | |
| Supply Voltage Range | | DVDD | 2.25 | 2.5 | 2.75 | V |
| | | AVDD | 3.00 | 3.3 | 3.6 | |
| | | DVDDIO | 4.5 | 5.0 | 5.5 | |
| AVDD Supply Current | | All analog functions enabled | | 12 | 18 | mA |
| | | All analog functions disabled | | 3 | 10 | μA |
| | | Incremental AVDD supply current | LNA | | 2.4 | mA |
| | | | Sigma-delta ADC | | 12 | |
| | | | SAR ADC, 250ksps, $f_{ADCCLK} = 4MHz$ | | 600 | μA |
| | | | PLL | | 300 | |
| | | | Supply voltage supervisors | | 3 | |
| | | | Internal voltage reference | | 220 | |
| | Reference buffer | | | 300 | | |
| | Bias (any AVDD module enabled) | | 1.5 | mA | | |
| DVDD Supply Current | | | | 11 | | mA |
| DVDDIO Supply Current | | | | 2.5 | | mA |
| DIGITAL INPUTS (GPIO, UART, JTAG, SPI™) | | | | | | |
| Input High Voltage | | | $V_{DVDDIO} - 1$ | | | V |
| Input Low Voltage | | | | | 0.8 | V |
| Input Hysteresis | | $V_{DVDDIO} = 5.0V$ | | 500 | | mV |
| Input Leakage Current | | Digital input voltage = DGND or DVDDIO, pullup disabled | | ± 0.01 | ± 1 | μA |
| Pullup/Pulldown Resistance | | Pulled up to DVDDIO internally, pulled down to DGND internally | | 150 | | k Ω |
| Input Capacitance | | | | 15 | | pF |

SPI is a trademark of Motorola, Inc.

16-Bit, RISC, Microcontroller-Based, Ultrasonic Distance-Measuring System

MAXQ7667

ELECTRICAL CHARACTERISTICS (continued)

(V_{DVDDIO} = +5V, V_{AVDD} = +3.3V; V_{DVDD} = +2.5V, system clock (f_{SYSCLK}) = 16MHz, burst frequency (f_{BURST}) = bandpass frequency (f_{BPF}) = 50kHz, C_{REFBG} = C_{REF} = 1μF in parallel with 0.01μF, f_{ADCCLK} = 2MHz (SAR data rate = 125ksps), T_A = T_{MIN} to T_{MAX}, unless otherwise specified. Typical values are at T_A = +25°C.)

| PARAMETER | SYMBOL | CONDITIONS | MIN | TYP | MAX | UNITS |
|--|--------|--|---------------------------|-------|------|-------|
| DIGITAL OUTPUTS (GPIO, UART, JTAG, SPI) | | | | | | |
| Output Low Voltage | | I _{SINK} = 0.5mA, drive strength = low | | | 0.4 | V |
| | | I _{SINK} = 1.0mA, drive strength = high | | | 0.4 | |
| Output High Voltage | | I _{SOURCE} = 0.5mA, drive strength = low | V _{DVDDIO} - 0.5 | | | V |
| | | I _{SOURCE} = 1.0mA, drive strength = high | V _{DVDDIO} - 0.5 | | | |
| Maximum Output Impedance | | Drive strength = low | | 880 | | Ω |
| | | Drive strength = high | | 450 | | |
| Three-State Leakage | | | | ±0.01 | ±1 | μA |
| Three-State Capacitance | | | | 15 | | pF |
| BURST OUTPUT | | | | | | |
| Output Low Voltage | | I _{SINK} = 8mA | | | 0.4 | V |
| Output High Voltage | | I _{SOURCE} = 8mA | V _{DVDDIO} - 0.5 | | | V |
| Maximum Output Impedance | | Drive strength = low | | 90 | | Ω |
| | | Drive strength = high | | 45 | | |
| Three-State Leakage | | | | ±0.01 | ±1 | μA |
| Three-State Capacitance | | | | 15 | | pF |
| Short-Circuit Current | | Burst drive set to high | | 50 | | mA |
| RESET | | | | | | |
| Internal Pullup Resistance | | Pulled up to DVDDIO | | 120 | | kΩ |
| Output Low Voltage | | I _{SINK} = 0.5mA | | | 0.4 | V |
| Output High Voltage | | No external load | V _{DVDDIO} - 0.5 | | | V |
| Input Low Voltage | | When driven by external source | | | 0.8 | V |
| Input High Voltage | | When driven by external source | V _{DVDDIO} - 1 | | | V |
| UART/LIN INTERFACE (UTX, URX) | | | | | | |
| UART Baud Rates | | Asynchronous mode (system clock/32) | | | 500 | kbps |
| | | Synchronous mode (system clock/8) | | | 2000 | |
| | | LIN 2.0 compatibility (Note 3) | 1 | | 20 | |

16-Bit, RISC, Microcontroller-Based, Ultrasonic Distance-Measuring System

ELECTRICAL CHARACTERISTICS (continued)

($V_{DDIO} = +5V$, $V_{AVDD} = +3.3V$; $V_{DVDD} = +2.5V$, system clock (f_{SYSCLK}) = 16MHz, burst frequency (f_{BURST}) = bandpass frequency (f_{BPF}) = 50kHz, $C_{REFBG} = C_{REF} = 1\mu F$ in parallel with $0.01\mu F$, $f_{ADCCLK} = 2MHz$ (SAR data rate = 125ksps), $T_A = T_{MIN}$ to T_{MAX} , unless otherwise specified. Typical values are at $T_A = +25^\circ C$.)

| PARAMETER | SYMBOL | CONDITIONS | MIN | TYP | MAX | UNITS |
|--|--------------------------|-------------------------------------|----------------------|-------------|-----|--------|
| SPI INTERFACE TIMING (Figures 11 and 12) | | | | | | |
| SPI Master Operating Frequency | $1/t_{MCK}$ | $0.5 \times f_{SYSCLK}$ | | | 8 | MHz |
| SPI Slave Operating Frequency | $1/t_{SCK}$ | $0.25 \times f_{SYSCLK}$ | | | 4 | MHz |
| SCLK Output Pulse-Width High/Low | t_{MCH} , t_{MCL} | | $t_{MCK}/2$ - 25 | | | ns |
| MOSI Output Hold Time After SCLK Sample Edge | t_{MOH} | | $t_{MCK}/2$ - 25 | | | ns |
| MOSI Output Valid to Sample Edge | t_{MOV} | | $t_{MCK}/2$ - 25 | | | ns |
| MISO Input Valid to SCLK Sample Edge | t_{MIS} | | 25 | | | ns |
| MISO Input Hold Time After SCLK Sample Edge | t_{MIH} | | 0 | | | ns |
| SCLK Inactive to MOSI Inactive | t_{MLH} | | 0 | | | ns |
| SCLK Input Pulse-Width High/Low | t_{SCH} , t_{SCL} | | | $t_{SCK}/2$ | | ns |
| SS Active to First Shift Edge | t_{SSE} | | $4t_{SYSCLK}$ | | | ns |
| MOSI Input Setup Time to SCLK Sample Edge | t_{SIS} | | 25 | | | ns |
| MOSI Input Hold Time After SCLK Sample Edge | t_{SIH} | | 25 | | | ns |
| MISO Output Valid After SCLK Shift Edge Transition | t_{SOV} | | | | 50 | ns |
| SS Inactive Duration | t_{SSH} | | $t_{SYSCLK} +$ 25 | | | ns |
| SCLK Inactive to SS Rising Edge | t_{SD} | | $t_{SYSCLK} +$ 25 | | | ns |
| FLASH PROGRAMMING | | | | | | |
| Flash Erase Time | | Mass erase | 200 | | | ms |
| | | Page erase (512 bytes per page) | 20 | | | |
| Flash Programming Time | | 20 μ s per word | 657 | | | ms |
| Write/Erase Cycles | | | 10,000 | | | Cycles |
| Data Retention | | Average temperature = $+85^\circ C$ | 15 | | | Years |

Note 1: Noise measured at bandpass filter output with ECHO+ and ECHO- shorted divided by the gain with $f_{BPF} = 50kHz$.

Note 2: Gain adjust resolution typically ranges between 6.25% and 12.5%.

Note 3: LIN 2.0 specifies a maximum data rate of 20kbps. Higher data rates could be possible with compatible devices and suitable line conditions.

16-Bit, RISC, Microcontroller-Based, Ultrasonic Distance-Measuring System

MAXQ7667

Typical Operating Characteristics

($V_{DDIO} = +5V$, $V_{AVDD} = +3.3V$, $V_{DVDD} = +2.5V$, $f_{SYSCLK} = 16MHz$, burst frequency = bandpass frequency = 50kHz, $T_A = +25^\circ C$, unless otherwise noted.)

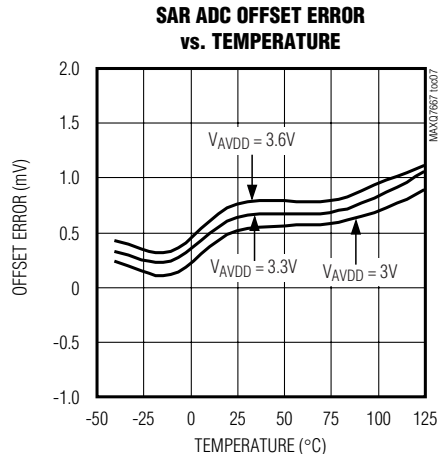
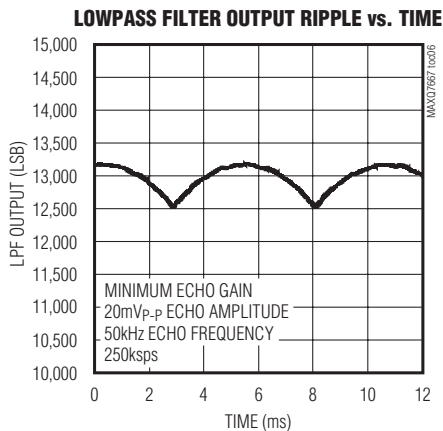
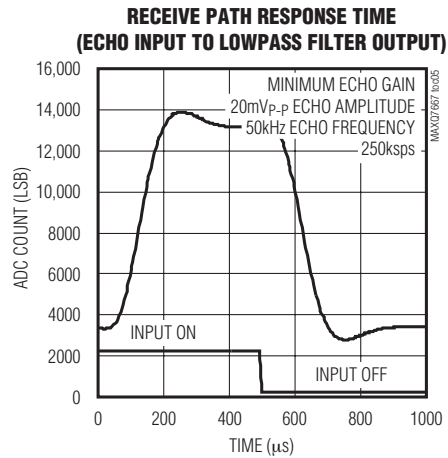
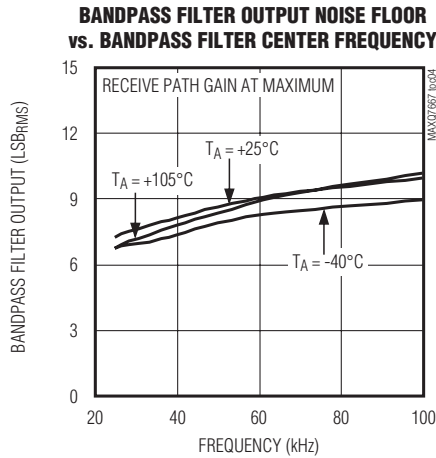
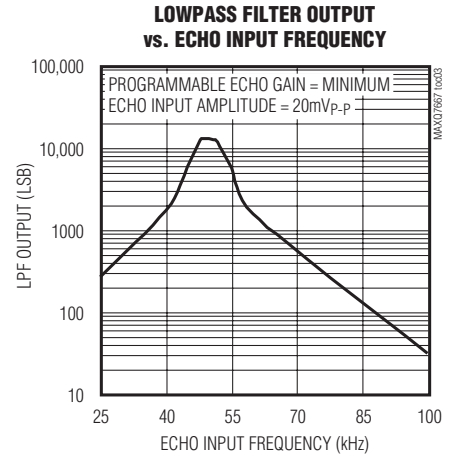
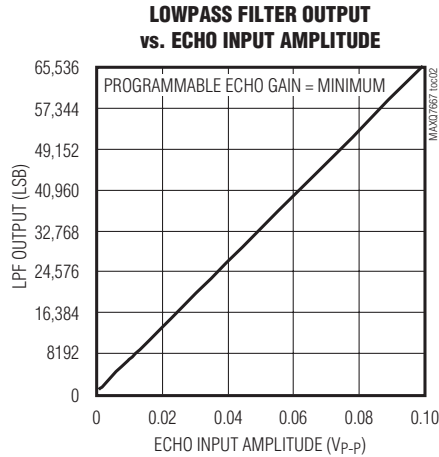
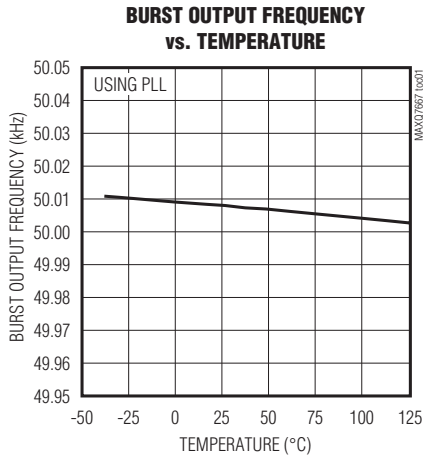

16-Bit, RISC, Microcontroller-Based, Ultrasonic Distance-Measuring System

Typical Operating Characteristics (continued)

($V_{DVDDIO} = +5V$, $V_{AVDD} = +3.3V$, $V_{DVDD} = +2.5V$, $f_{SYSCLK} = 16MHz$, burst frequency = bandpass frequency = 50kHz, $T_A = +25^\circ C$, unless otherwise noted.)

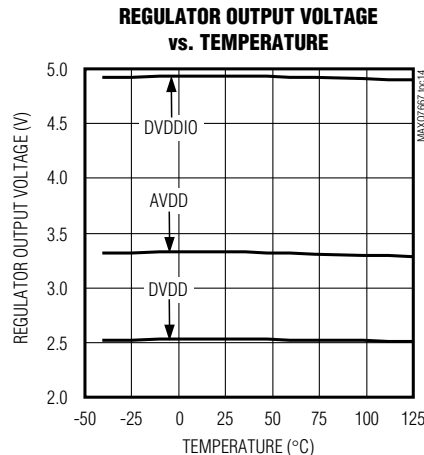
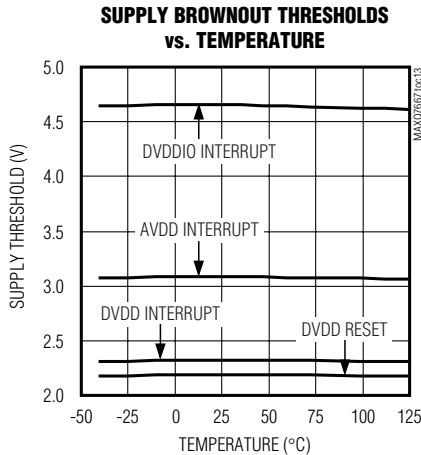
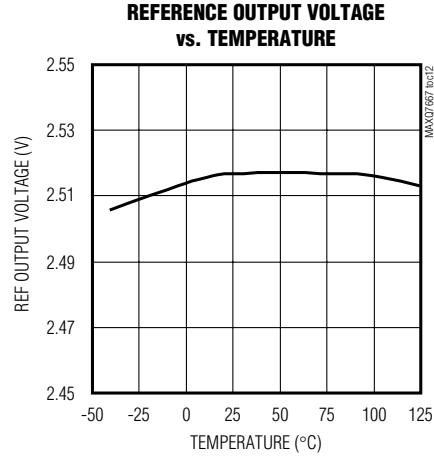
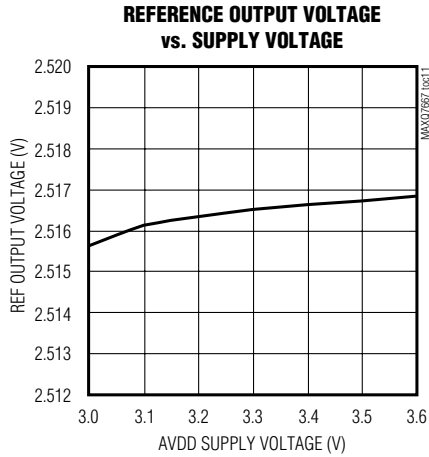
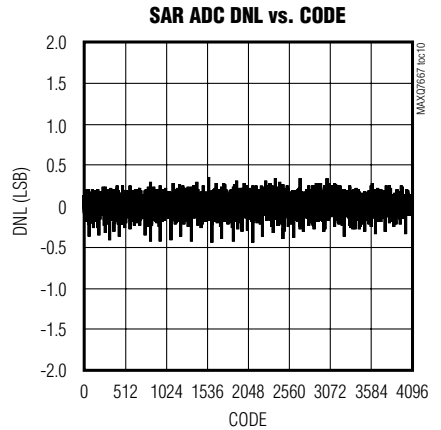
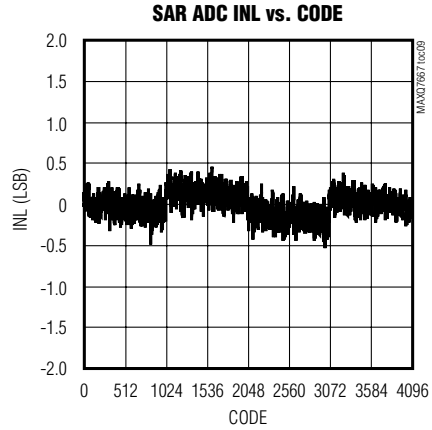
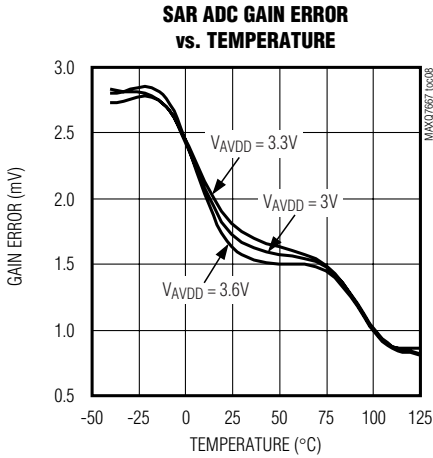

16-Bit, RISC, Microcontroller-Based, Ultrasonic Distance-Measuring System

Typical Operating Characteristics (continued)

($V_{DVDDIO} = +5V$, $V_{AVDD} = +3.3V$, $V_{DVDD} = +2.5V$, $f_{SYSCLK} = 16MHz$, burst frequency = bandpass frequency = 50kHz, $T_A = +25^\circ C$, unless otherwise noted.)

MAXQ7667

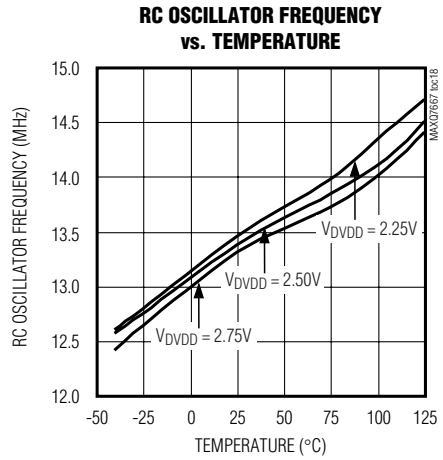
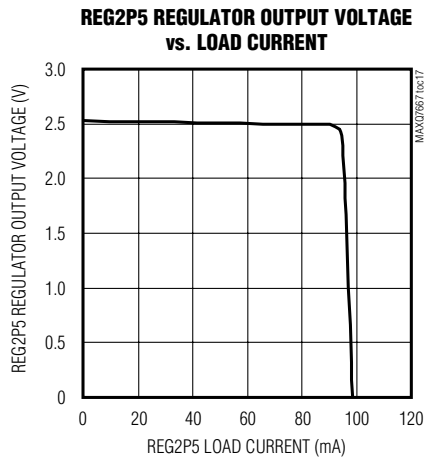
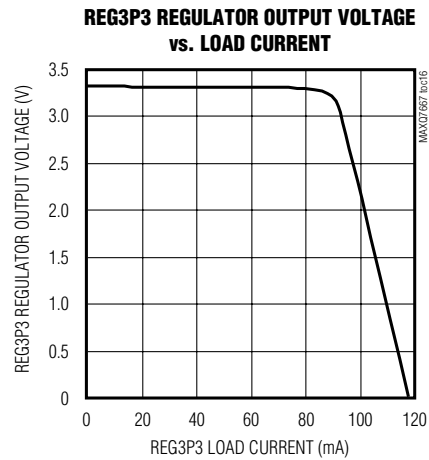
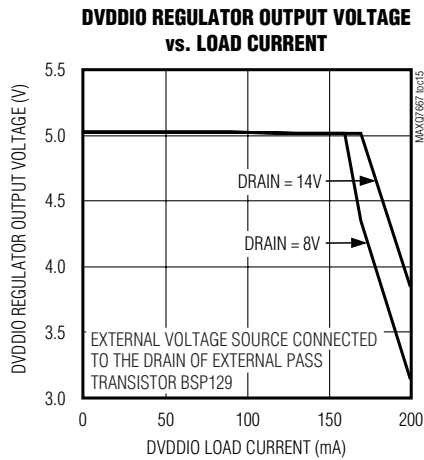

16-Bit, RISC, Microcontroller-Based, Ultrasonic Distance-Measuring System

Pin Description

| PIN | NAME | FUNCTION |
|-----------|--------------------------------|---|
| 1 | P1.3/TCK | Port 1 Data 3/JTAG Serial Clock Input. P1.3 is a general-purpose digital I/O. TCK is the JTAG serial test clock input. Refer to the <i>MAXQ7667 User's Guide</i> Sections 5 and 11. |
| 2 | P1.4/MOSI | Port 1 Data 4/SPI Serial Data Output. P1.4 is a general-purpose digital I/O. MOSI is the master output, slave input for the SPI interface. Refer to the <i>MAXQ7667 User's Guide</i> Sections 5 and 9. |
| 3 | P1.5/MISO | Port 1 Data 5/SPI Serial Data Input. P1.5 is a general-purpose digital I/O. MISO is the master input, slave output for the SPI interface. Refer to the <i>MAXQ7667 User's Guide</i> Sections 5 and 9. |
| 4 | P1.6/SCLK | Port 1 Data 6/SPI Serial Clock Output. P1.6 is a general-purpose digital I/O. SCLK is the serial clock for the SPI interface. SCLK is an input when operating as a slave and an output when operating as a master. Refer to the <i>MAXQ7667 User's Guide</i> Sections 5 and 9. |
| 5 | P1.7/SYNC/SS | Port 1 Data 7/Schedule Timer Sync Input/SPI Slave Select. P1.7 is a general-purpose digital I/O. A rising edge on the SYNC input resets the schedule timer. In SPI slave mode, SS is the SPI slave-select input. In SPI master mode, use SS or a GPIO to manually select an external slave. Refer to the <i>MAXQ7667 User's Guide</i> Sections 5, 7, and 9. |
| 6, 19, 42 | DVDD | Digital Supply Voltage. Connect DVDD directly to a +2.5V external source or to REG2P5 output for single supply operation. Bypass DVDD to DGND with a 0.1µF capacitor as close as possible to the device. Connect all DVDD nodes together. |
| 7, 18, 43 | DGND | Digital Ground. Connect all DGND nodes together. Connect to AGND at a single point. |
| 8, 17, 44 | DVDDIO | Digital I/O Supply Voltage. DVDDIO powers all digital I/Os except for XIN and XOUT. Bypass DVDDIO to DGND with a 0.1µF capacitor as close as possible to the device. Connect all DVDDIO nodes together. |
| 9 | P0.0/URX | Port 0 Data 0/UART Receive Data Input. P0.0 is a general-purpose digital I/O. URX is a UART or LIN data receive input. Refer to the <i>MAXQ7667 User's Guide</i> Sections 5 and 8. |
| 10 | P0.1/UTX | Port 0 Data 1/UART Transmit Data Output. P0.1 is a general-purpose digital I/O. UTX is a UART or LIN data transmit output. Refer to the <i>MAXQ7667 User's Guide</i> Sections 5 and 8. |
| 11 | P0.2/ $\overline{\text{TXEN}}$ | Port 0 Data 2/UART Transmit Output. P0.2 is a general-purpose digital I/O. $\overline{\text{TXEN}}$ asserts low when the UART is transmitting. Use $\overline{\text{TXEN}}$ to enable an external LIN/UART transceiver. Refer to the <i>MAXQ7667 User's Guide</i> Sections 5 and 8. |
| 12 | P0.3/T0/ ADCCTL | Port 0 Data 3/Timer 0 I/O/ADC Control Input. P0.3 is a general-purpose digital I/O. T0 is the primary Type 2 timer/counter 0 output or input. ADCCTL is a sampling/conversion trigger input for the SAR ADC. Refer to the <i>MAXQ7667 User's Guide</i> Sections 5, 6, and 14. |
| 13 | P0.4/T0B | Port 0 Data 4/Timer 0B I/O/Comparator Output. P0.4 is a general-purpose digital I/O. T0B is the secondary Type 2 timer/counter 0 output or input. Refer to the <i>MAXQ7667 User's Guide</i> Sections 5 and 6. |
| 14 | P0.5/T1 | Port 0 Data 5/Timer 1 I/O. P0.5 is a general-purpose digital I/O. T1 is the primary Type 2 timer/counter 1 output or input. Refer to the <i>MAXQ7667 User's Guide</i> Sections 5 and 6. |
| 15 | P0.6/T2 | Port 0 Data 6/Timer 2 I/O. P0.6 is a general-purpose digital I/O. T2 is the primary Type 2 timer/counter 2 output or input. Refer to the <i>MAXQ7667 User's Guide</i> Sections 5 and 6. |
| 16 | P0.7/T2B | Port 0 Data 7/Timer 2B I/O. P0.7 is a general-purpose digital I/O. T2B is the secondary Type 2 timer/counter 2 output or input. Refer to the <i>MAXQ7667 User's Guide</i> Sections 5 and 6. |
| 20 | XIN | Crystal Oscillator Input. Connect an external crystal or resonator between XIN and XOUT. When using an external clock source drive XIN with 2.5V level clock while leaving XOUT unconnected. Connect XIN to DGND when an external clock source is not used. |

16-Bit, RISC, Microcontroller-Based, Ultrasonic Distance-Measuring System

Pin Description (continued)

MAXQ7667

| PIN | NAME | FUNCTION |
|------------|----------|--|
| 21 | XOUT | Crystal Oscillator Output. Connect an external crystal or resonator between XIN and XOUT. Leave XOUT unconnected when driving XIN with a 2.5V level clock or when an external clock source is not used. |
| 22 | REG2P5 | +2.5V Voltage Regulator Output |
| 23 | REG3P3 | +3.3V Voltage Regulator Output |
| 24 | GATE5 | +5V DVDDIO Voltage Regulator Control Output. GATE5 controls an external npn or nMOS transistor that passes power to DVDDIO. |
| 25 | RESET | Reset Input/Output. RESET is open drain with an internal pullup resistor to DVDDIO. Internal circuitry pulls RESET low when V _{DVDDIO} falls below its brownout reset value or watchdog reset is enabled and the watchdog timeout period expires. Force RESET low externally for manual reset. |
| 26 | FILT | PLL VCO Control Input. Connect external filter components on FILT for the internal PLL circuit. See the <i>Typical Application Circuit/Functional Diagram</i> . |
| 27, 32 | AVDD | Analog Supply Voltage. Connect all AVDD inputs directly to a +3.3V source or to REG3P3 for self-powered operation. Bypass each AVDD to AGND with a 0.1μF capacitor as close as possible to the device. |
| 28, 31, 33 | AGND | Analog Ground. Connect all AGND nodes together. Connect to DGND at a single point. |
| 29 | ECHON | Negative Echo Input. AC-couple ECHON to an ultrasonic transducer. |
| 30 | ECHOP | Positive Echo Input. AC-couple ECHOP to an ultrasonic transducer. |
| 34 | REF | ADC Reference Input/Reference Buffer Output. When using the internal reference, the buffered bandgap reference voltage (V _{REF}) is provided for both SAR and sigma-delta ADCs. When using an external reference, apply an external voltage source ranging between 1V and V _{AVDD} at REF. Disable the reference buffer when applying an external reference at REF. Bypass REF to AGND with a 0.47μF capacitor. |
| 35 | REFBG | +2.5V Reference Output/Reference Buffer Input. Bypass to AGND with a 0.47μF capacitor. |
| 36 | AIN0 | SAR ADC Input 0. AIN0 pairs with AIN1 in differential mode. |
| 37 | AIN1 | SAR ADC Input 1. AIN1 pairs with AIN0 in differential mode. |
| 38 | AIN2 | SAR ADC Input 2. AIN2 pairs with AIN3 in differential mode. |
| 49 | AIN3 | SAR ADC Input 3. AIN3 pairs with AIN2 in differential mode. |
| 40 | AIN4 | SAR ADC Input 4 |
| 41 | N.C. | No Connection. Internally connected. Leave unconnected. |
| 45 | BURST | Burst Output. Burst is the ultrasonic transducer excitation pulse output. BURST remains in three-state mode on power-up. |
| 46 | P1.0/TDO | Port 1 Data 0/JTAG Output. P1.0 is a general-purpose digital I/O. TDO is the JTAG serial data output. Refer to the <i>MAXQ7667 User's Guide</i> Sections 5 and 11. |
| 47 | P1.1/TMS | Port 1 Data 1/JTAG Test Mode-Select Input. P1.1 is a general-purpose digital I/O. TMS is the JTAG mode-select input. Refer to the <i>MAXQ7667 User's Guide</i> Sections 5 and 11. |
| 48 | P1.2/TDI | Port 1 Data 2/JTAG Input. P1.2 is a general-purpose digital I/O. TDI is the JTAG serial data input. Refer to the <i>MAXQ7667 User's Guide</i> Sections 5 and 11. |

16-Bit, RISC, Microcontroller-Based, Ultrasonic Distance-Measuring System

Typical Application Circuit/Functional Diagram

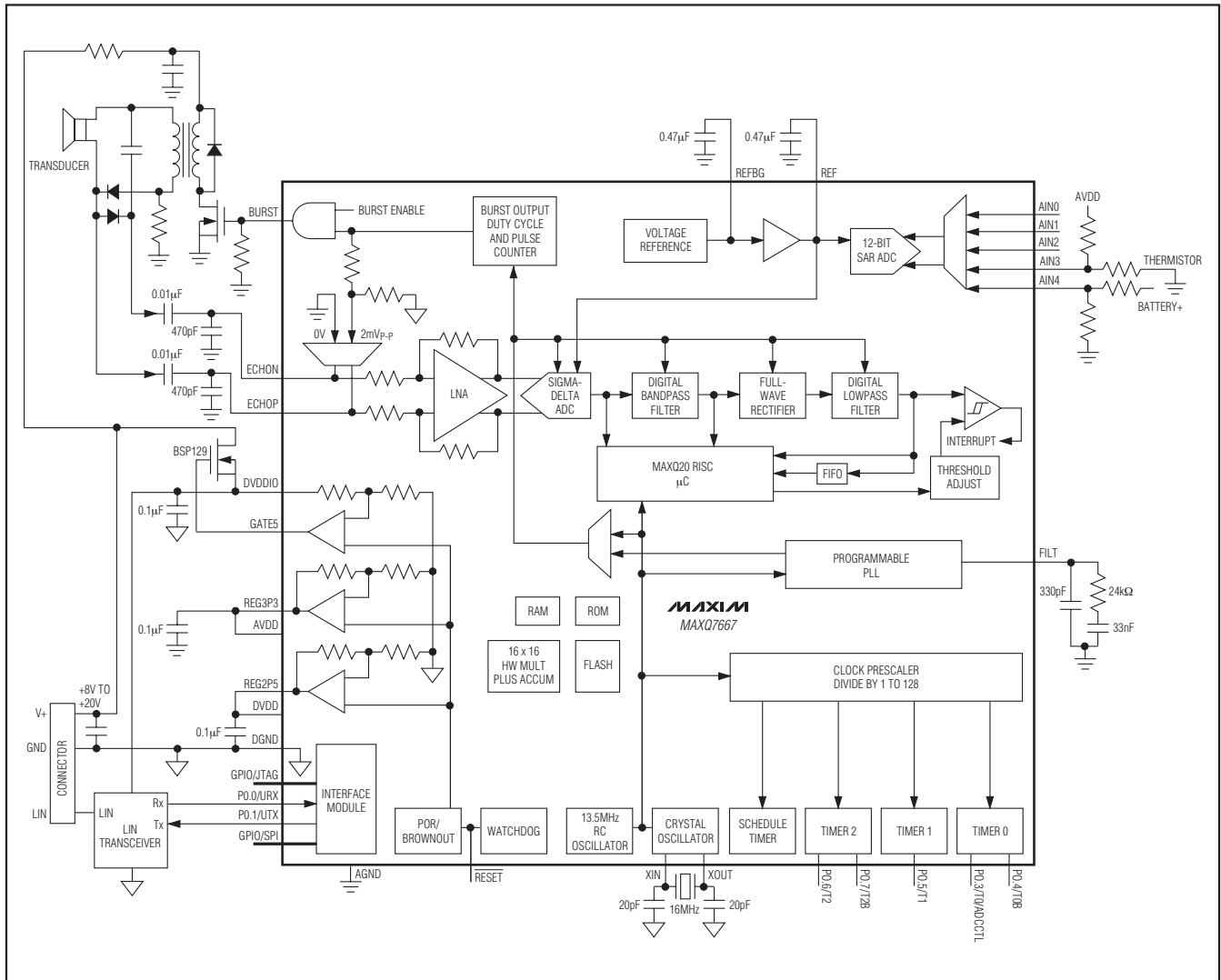

16-Bit, RISC, Microcontroller-Based, Ultrasonic Distance-Measuring System

MAXQ7667

Detailed Features

- ◆ **Smart Analog Peripherals**
 - Dedicated Ultrasonic Burst Generator
 - Echo Receiving Path
 - Low-Noise Amplifier
 - Time Variable Gain Amplifier
 - 16-Bit Sigma-Delta ADC
 - Digital Bandpass Filter
 - Full-Wave Rectifier and Digital Lowpass Filter
 - 8-Deep, 16-Bit Wide FIFO Simplifies Real-Time Processing
 - Magnitude Comparator
 - 5-Channel, 12-Bit SAR ADC with 250ksps Sampling Rate
 - Internal Bandgap Voltage Reference for the ADCs (Also Accepts External Voltage Reference)
- ◆ **Timer/Digital I/O Peripherals**
 - SPI Interface
 - Three 16-Bit (or Six 8-Bit) Programmable Type 2 Timers/Counters
 - 16-Bit Schedule Timer
 - Programmable Watchdog Timer
 - 16 General-Purpose Digital I/Os with Multipurpose Capability
- ◆ **High-Performance, Low-Power, 16-Bit RISC Core**
 - 1MHz–16MHz Operation, Approaching 1MIPS per 1MHz
 - Low Power (< 2.5mA/MIPS, DVDD = +2.5V)
 - 16-Bit Instruction Word, 16-Bit Data Bus
 - 33 Instructions (Most Require Only One Clock Cycle)
 - 16-Level Hardware Stack
 - Three Independent Data Pointers with Automatic Increment/Decrement
- ◆ **Program and Data Memory**
 - Internal 32KB Program Flash
 - Internal 4KB Data RAM
 - Internal 8KB Utility ROM
- ◆ **Crystal/Clock Module**
 - 1MHz–16MHz External Crystal Oscillator
 - 13.5MHz Internal RC Oscillator
 - External Clock Source Operation
- ◆ **16 x 16 Hardware Multiplier with 48-Bit Accumulator, Single Clock Cycle Operation**
- ◆ **Power-Management Module**
 - Power-On Reset (POR)
 - Power-Supply Supervisor/Brownout Detection for All Supplies
 - On-Chip +5V, +3.3V, and +2.5V Regulators for Single Supply Operation
- ◆ **JTAG Interface**
 - Extensive Debug and Emulation Support
 - In-System Test Capability
 - Flash-Memory-Program Download
- ◆ **UART**
 - Synchronous and Asynchronous Transfers
 - Independent Baud-Rate Generator
 - 2-Wire Interface
 - Transmit and Receive FIFOs
- ◆ **LIN**
 - Supports LIN 1.3, LIN 2.0, and SAE J2602
 - Automatic Baud-Rate Detection and LIN Frame Synchronization
 - Up to 64 Bytes Frame Length
 - Automatic Calculation of Standard (LIN 1.3) and Enhanced (LIN 2.0) Checksums
- ◆ **7mm x 7mm, 48-Pin LQFP Package**
- ◆ **-40°C to +125°C Operating Temperature Range**

16-Bit, RISC, Microcontroller-Based, Ultrasonic Distance-Measuring System

Detailed Description

The ultrasonic distance-measurement peripherals in the MAXQ7667 include a burst signal generator for acoustic transmission and mixed signal circuits for amplifying and digitizing echo signals ranging between 25kHz and 100kHz. The burst signal is a square wave with adjustable duty cycle and pulse count. The burst is derived either directly from the system clock or from a programmable PLL locked to the system clock. The MAXQ7667 effectively digitizes the echo signals received at the ECHOP and ECHON inputs using an LNA, sigma-delta ADC with variable analog gain amplifier, noise-limiting digital bandpass filter, digital full-wave rectifier, and a digital lowpass filter (see the *Typical Application Circuit/Functional Diagram*). The device detects echo signals at the burst frequency with amplitudes ranging from 10 μ V_{P-P} to 100mV_{P-P}. Echoes greater than 100mV_{P-P} and less than 2V_{P-P} are internally clipped but do not saturate the receiver. To optimize echo reception, the clock used for processing the echo locks to the burst frequency. The MAXQ7667's burst generator can generate higher frequencies, but the maximum usable frequency for the echo receive path is 100kHz. For applications requiring transducer frequencies above 100kHz, implement an external echo receive path. The SAR ADC can then digitize the filtered echo envelope.

An integrated 16-bit RISC μ C (MAXQ20) provides timing control, signal processing, and data I/O. The 16-bit Harvard architecture RISC core executes most instructions in a single clock cycle from instruction fetch to cycle completion. The MAXQ20 provides optimal performance for noise-sensitive analog applications.

The MAXQ7667 includes a 13.5MHz RC oscillator, external crystal oscillator, watchdog timer, schedule timer, three general-purpose Type 2 timers/counters, two 8-bit GPIO ports, SPI interface, JTAG interface, LIN capable UART interface, 12-bit SAR ADC with five multiplexed input channels, supply-voltage monitors, and a voltage reference for communication, diagnostics, and miscellaneous support.

Burst Controller

The MAXQ7667 provides a square-wave burst signal at the BURST output. Use the burst control to transmit an ultrasonic signal. Typical applications use the burst signal to switch an external transistor that drives a high-voltage transformer, which excites the transducer (see the *Typical Application Circuit/Functional Diagram*). Use software to configure the duty cycle, frequency, number of pulses, and drive current of the burst. See Section 17 of the *MAXQ7667 User's Guide*.

Derive the burst signal either directly from the system clock or from a programmable oscillator phase locked to the system clock (Figure 1). Using the system clock limits the burst frequency to one of 16 choices. Integer division of the system clock generates these 16 frequencies. The PLL allows a fractional division of the system clock. Any frequency within the PLL range is selectable to a resolution of 0.13% or better.

When using the internal PLL, connect external filter components (C1, R1, and C2) to FILT as shown in Figure 1. These components filter the analog voltage that controls the VCO in the PLL. The filter component values shown in the figure are suitable for the entire PLL frequency range.

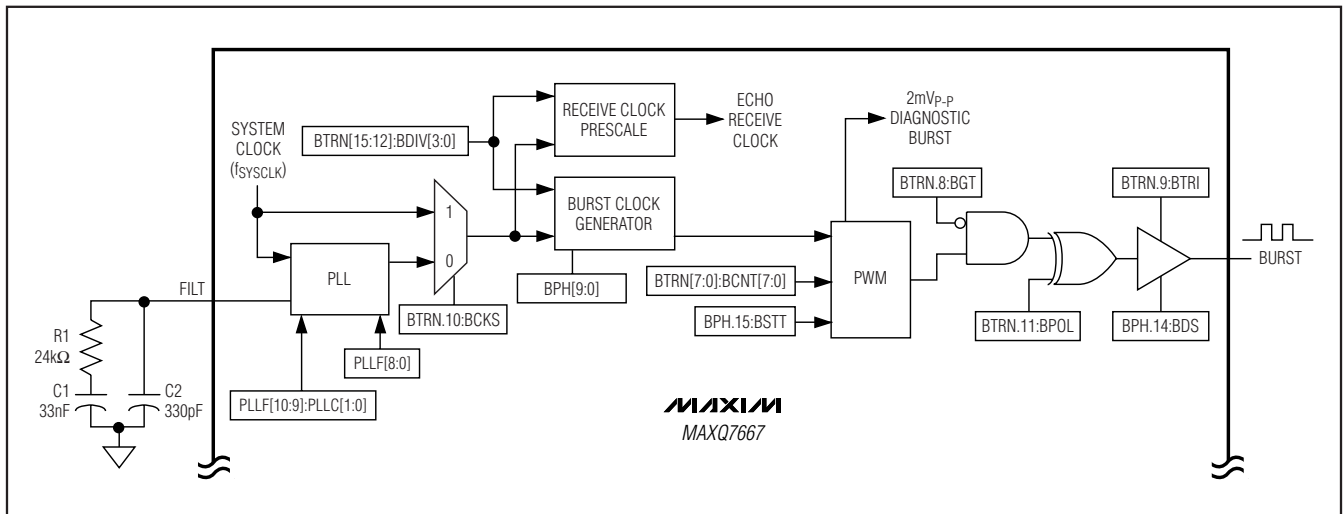

Figure 1. Burst Transmission Stage

16-Bit, RISC, Microcontroller-Based, Ultrasonic Distance-Measuring System

MAXQ7667

Echo Receive Path

Low-Noise Amplifier (LNA)

The LNA provides a 40V/V fixed gain to the input signal. The differential inputs of the LNA are ECHOP and ECHON. For proper biasing of the LNA, AC-couple the transducer or any external circuitry to ECHOP and ECHON. For a single-ended input signal, AC-couple the signal to ECHOP with a 0.01μF capacitor and connect ECHON to AGND through a 0.01μF capacitor placed as close as possible to the signal source. The outputs of the LNA connect to the inputs of a 16-bit sigma-delta ADC and can connect internally to the AIN0 and AIN1 inputs of the SAR ADC for external monitoring (Figure 2).

Diagnostic Signals

An analog multiplexer located at the input of the LNA selects one of three possible signals for processing by the echo receive path; the normal echo signal AC-coupled to the ECHOP and ECHON inputs, 0V signal, or a 2mV_{P-P} internally generated signal (Figure 2). The 2mV_{P-P} square-wave signal, with frequency and duty cycle matching the burst signal, allows the echo receive chain to process a simulated echo.

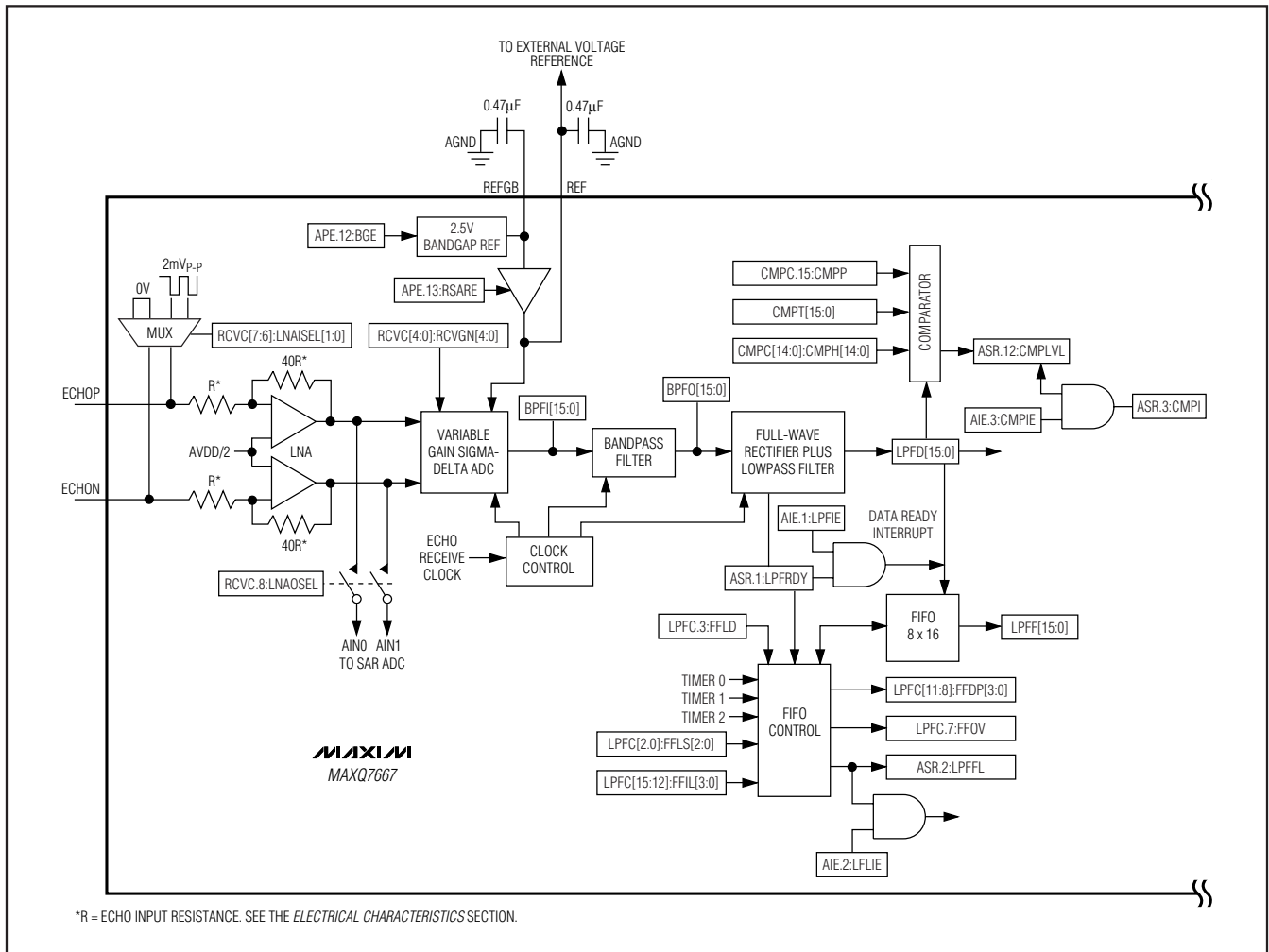

*R = ECHO INPUT RESISTANCE. SEE THE ELECTRICAL CHARACTERISTICS SECTION.

Figure 2. Echo Receive Path

16-Bit, RISC, Microcontroller-Based, Ultrasonic Distance-Measuring System

Sigma-Delta ADC

The MAXQ7667 features a 16-bit sigma-delta ADC with an analog gain adjustable from 38dB to 60dB (including the fixed LNA gain) with a maximum gain step of 12.5% (typical). Gain changes settle within one ADC conversion. Use software to create a virtual time variable gain amplifier. A digital bandpass and lowpass filters remove switching glitches and DC offset at the output of the ADC.

In a typical application, the software sets the gain to a low value when the burst is first sent and increases the gain as the time from when the burst was sent increases. As a result, strong echoes from nearby objects are processed without clipping while small signals from distant objects are processed with the maximum gain. The ADC samples the amplified echo signal from the LNA at 80 times the burst output frequency. The ADC provides conversion results at a data rate equal to 10 times the burst output frequency. The ADC conversion results also load to an 8-deep first-in-first-out (FIFO) at the native data rate or a separate time base without loading the CPU.

Digital Bandpass Filter

The digital bandpass filter has a center frequency that tracks the burst output frequency. The bandpass width is 14% of the center frequency. The bandpass filter provides the 16-bit output data at a data rate equal to 10 times the burst output frequency.

Full-Wave Rectifier

The full-wave rectifier detects the envelope of the digital bandwidth filter output to generate a DC output proportional to the peak-to-peak amplitude of the input signal. Full-wave rectification allows the digital lowpass filter to respond faster without excessive ripple.

Digital Lowpass Filter

The lowpass filter removes the ripple from the full-wave detector output. The output of the lowpass filter is available at a data rate equal to five times the burst output frequency. The corner frequency is 1/5 the burst frequency with approximately 40dB per decade rolloff. The 16-bit output data of the lowpass filter is stored in a FIFO register with a depth of eight samples. The MAXQ7667 allows data transfer from the lowpass filter

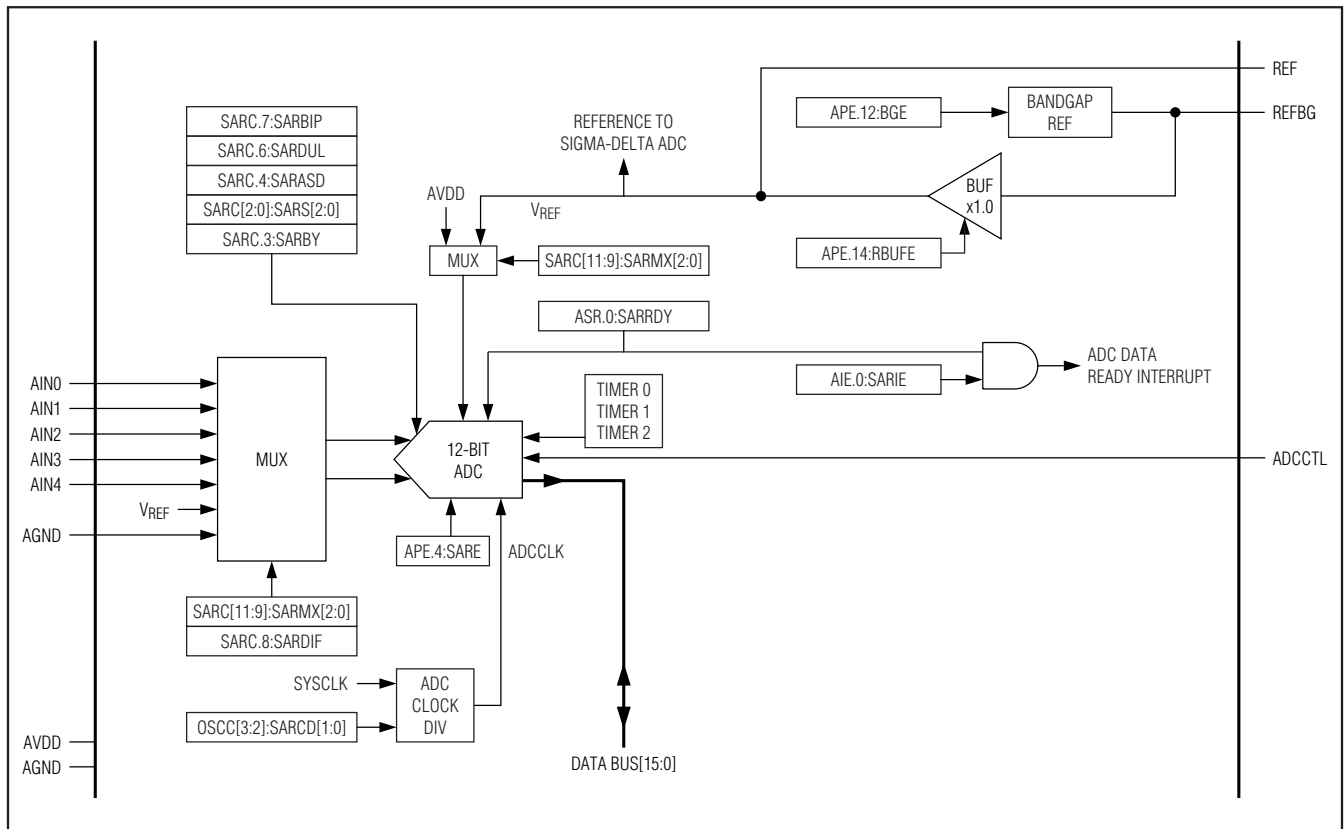

Figure 3. SAR ADC Block Diagram

16-Bit, RISC, Microcontroller-Based, Ultrasonic Distance-Measuring System

output to the FIFO automatically each time the lowpass filter output updates, through the control of one of the timer outputs, or through software. The device includes a FIFO depth counter with programmable interrupt levels and generates an interrupt if a FIFO overflow condition occurs. The output of the digital lowpass filter connects to a digital comparator that can generate an interrupt for a specified echo signal level.

Digital Comparator and Threshold Adjust

The digital comparator output asserts when the echo amplitude at the output of the digital lowpass filter crosses a given threshold. The comparator's threshold level, hysteresis, and interrupt polarity are programmable.

SAR ADC

The MAXQ7667 incorporates a 12-bit unbuffered SAR ADC with sample-and-hold and conversion rate up to 250ksps. The ADC allows measurements of tempera-

ture, battery voltage, or other parameters using five single-ended or two fully differential analog inputs (AIN0–AIN4). All of the analog inputs have a range of 0 to V_{REF} in unipolar mode and $\pm V_{REF}/2$ in bipolar mode.

The SAR ADC supports three different conversion start sources: timers, ADC control input (ADCCTL), and software write. The conversion start source triggers the ADC acquisition and conversion. The system clock provides the ADC clock frequency programmable to 1/2, 1/4, 1/8, or 1/16 of the system clock. Use internal bandgap reference, external reference, or AVDD for voltage reference of the SAR ADC. Figure 3 shows a simplified block diagram of the SAR ADC.

The output of the SAR ADC is straight binary in unipolar mode and two's complement in bipolar mode. Figures 4 and 5 show the ADC transfer functions in unipolar mode and bipolar mode.

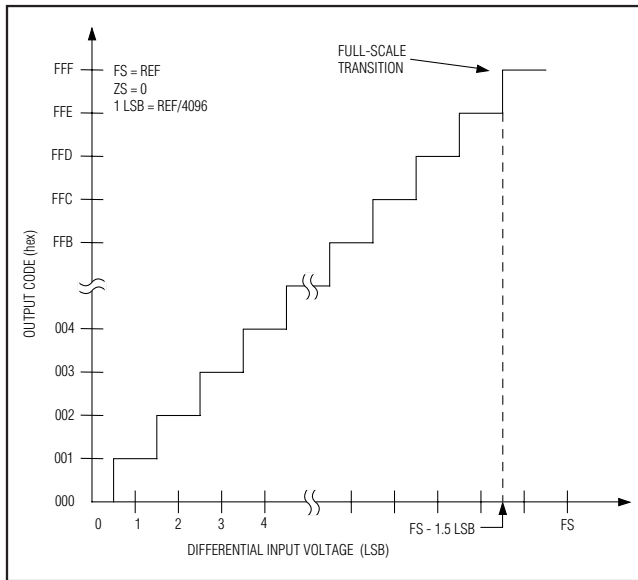

Figure 4. Unipolar Transfer Function

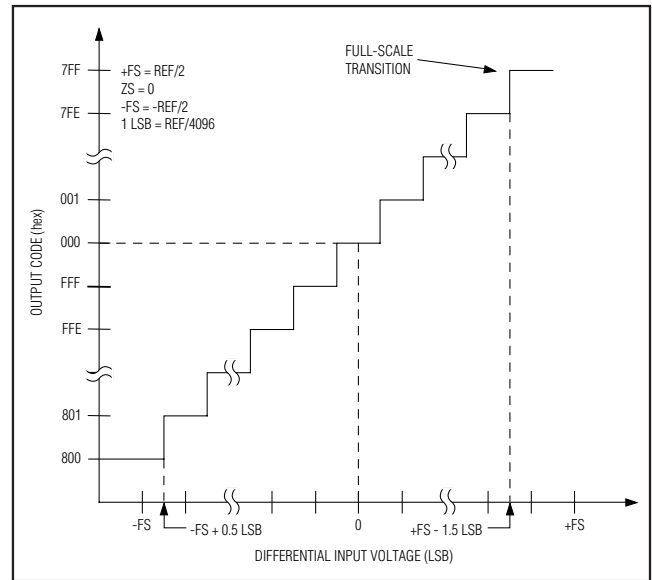

Figure 5. Bipolar Transfer Function

16-Bit, RISC, Microcontroller-Based, Ultrasonic Distance-Measuring System

SAR ADC Analog Input Track-and-Hold (T/H)

Figures 6 and 7 show the equivalent input circuit of the MAXQ7667 analog input architecture. During acquisition (track), a sampling capacitor charges to the positive input voltage at AIN0–AIN4 in single-ended mode or AIN0 and AIN2 in differential mode while a second sampling capacitor connects to AGND in single-ended mode or AIN1 and AIN3 in differential mode. The ADC conversion start source and the ADC dual mode selection bits control the T/H timing.

Voltage Reference

The MAXQ7667 supports three possible voltage reference sources for ADC conversion; 2.5V internal buffered bandgap reference, external source, and AVDD. The internal 2.5V bandgap reference has high initial accuracy and temperature coefficient of typically less than 100ppm/°C. When operating in internal reference mode, either the buffered output of the internal reference or AVDD connects to the SAR ADC while the buffered output of the internal reference connects to the sigma-delta ADC. When operating in external reference mode, an external source ranging between 1V and VAVDD applied at either the REF or REFBG inputs pro-

vides the reference to the SAR ADC and sigma-delta ADC. Bypass REF and REF to AGND with a 0.47µF capacitor for optimum performance. See Section 14 of the *MAXQ7667 User's Guide*.

Schedule Timer

The MAXQ7667's schedule timer provides general time-keeping and software synchronization to an external I/O. The schedule timer features include the following:

- 16-bit autoreload up-counter for the timer
- Programmable 16-bit alarm register
- Alarm interrupts
- Schedule timer incremented by a programmable system clock prescaler (1, 1/2, 1/4, 1/8, 1/16, 1/32, 1/64, 1/128)
- Schedule timer up-counter resettable through an external I/O pin, which allows synchronization of a schedule timer to an external event
- Wake-up alarm to pull the system clock from stop-mode to normal operation

Figure 8 shows a simplified block diagram of the schedule timer.

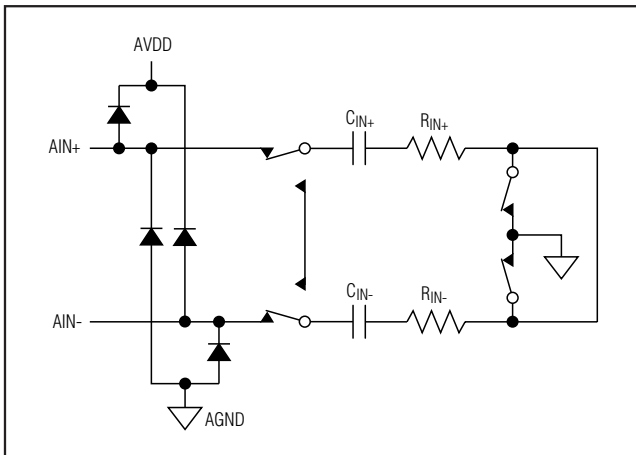

Figure 6. Equivalent Input Circuit (Track/Acquisition Mode)

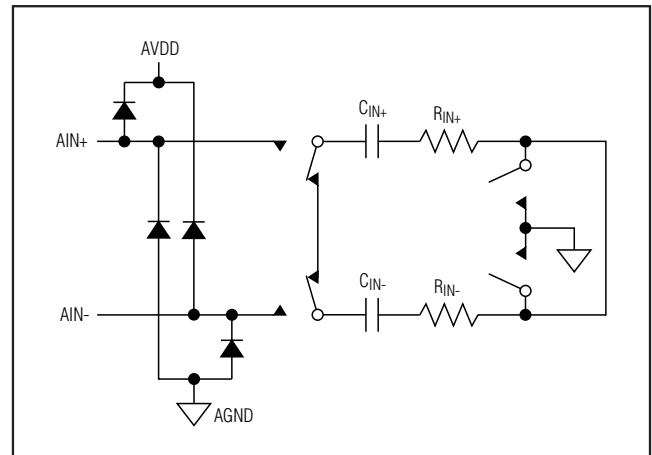

Figure 7. Equivalent Input Circuit (Hold/Conversion Mode)

16-Bit, RISC, Microcontroller-Based, Ultrasonic Distance-Measuring System

Type 2 Timers/Counters

The MAXQ7667 includes three 16-bit timers/counters with programmable I/O (Figure 9). Each timer is a Type 2 timer implemented in the MAXQ® family. The Type 2 timer is an autoreload 16-bit timer/counter offering the following functions:

- 8-bit/16-bit timer/counter
- Up/down autoreload
- Counter function of external pulse
- Capture
- Compare

Clock Sources

The MAXQ7667 oscillator module supplies the system clock for the μ C core and all of the peripheral modules. The high-frequency oscillator operates with a 1MHz to 16MHz crystal. Use the internal RC oscillator as the system clock for applications that do not require precise timing. See Section 15 of the *MAXQ7667 User's Guide*.

The MAXQ7667 supports the following master clock sources:

- Internal high-frequency oscillator drives an external 1MHz–16MHz crystal or ceramic resonator

- Internal, fast-starting, 13.5MHz RC oscillator (default oscillator at startup and in the event the external crystal fails)
- External 4MHz–16MHz clock input

Crystal Selection

The MAXQ7667 requires a crystal with the following specifications:

Frequency: 1MHz–16MHz

C_{LOAD}: 6pF (min)

Drive level: 5 μ W

Series resonance resistance: 30 Ω (max)

Note: Quartz crystal vendors often specify series resonance resistance (R₁). Series resonance resistance is the resistance observed when the resonator is in the series resonant condition. When a resonator is used in the parallel resonant mode with an external load capacitance, as is the case with the MAXQ7667 oscillator circuit, the effective resistance at the loaded frequency of oscillation is:

$$R_1 \times (1 + (CO/C_{LOAD}))^2$$

For typical shunt capacitance (CO) and load capacitance (C_{LOAD}) values, the effective resistance potentially exceeds R₁ by a factor of 2.

16-Bit, RISC, Microcontroller-Based, Ultrasonic Distance-Measuring System

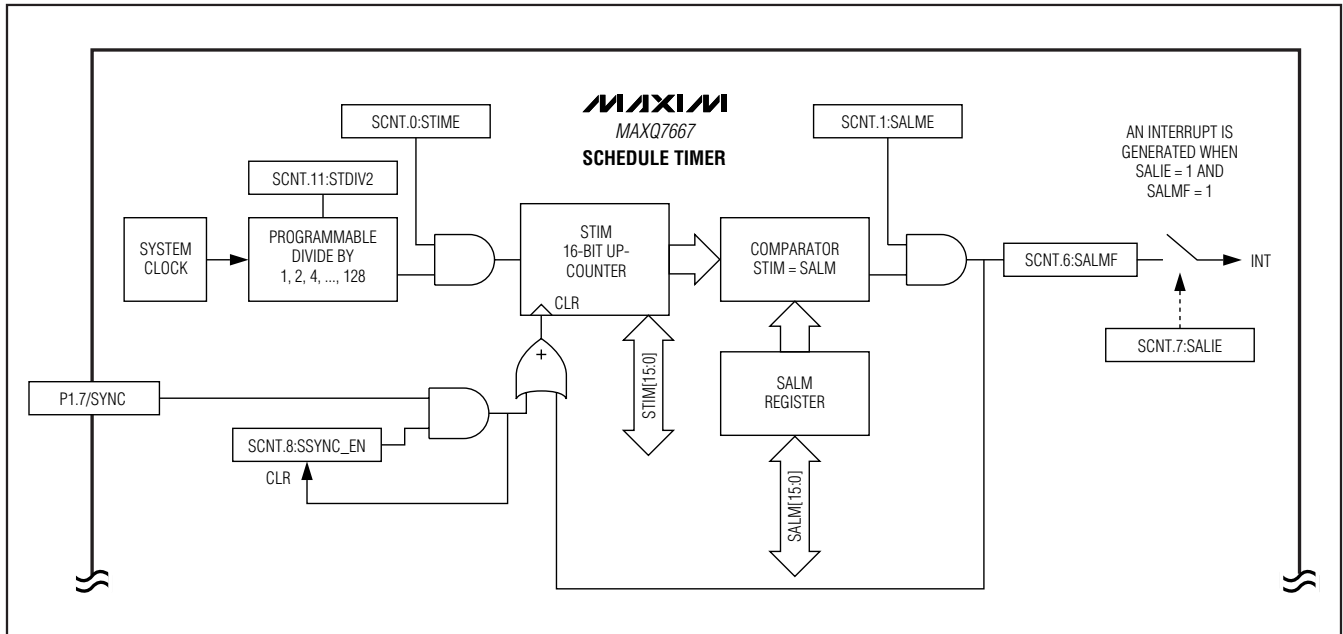

Figure 8. Schedule-Timer Module Block Diagram

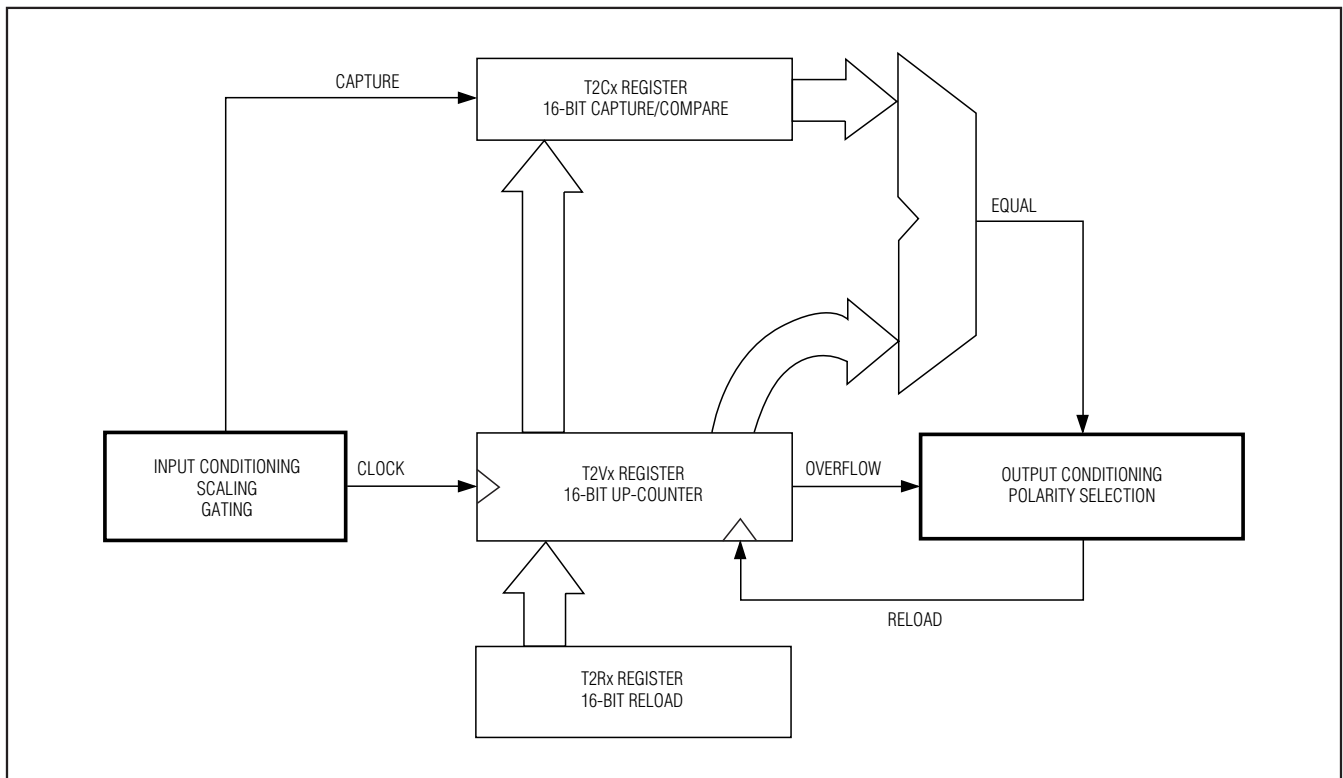

Figure 9. Type 2 Timer/Counter in 16-Bit Mode

16-Bit, RISC, Microcontroller-Based, Ultrasonic Distance-Measuring System

The following four digital I/Os form the TAP interface:

- TDO—Serial output signal for test instruction and data. Data transitions on the falling edge of TCK. TDO idles high when inactive. TDO serially transfers internal data to the external host. Data transfers least significant bit first.
- TDI—Serial input signal for test instruction and data. Transition data on the rising edge of TCK. TDO pulls high when unconnected. TDI serially transfers data from the external host to the internal TAP module shift registers. Data transfers least significant bit first.
- TCK—Serial clock for the test logic. When TCK stops at 0, storage elements in the test logic must retain their data indefinitely. Force TCK high when inactive.
- TMS—Test mode selection. The rising edge of TCK samples the test signals at TMS. The TAP controller decodes the test signals at TMS to control the test operation. Force TMS high when inactive.

UART/LIN Interface

The MAXQ7667 includes a UART/LIN transceiver combination that supports communication speeds up to 2MBd. The LIN standard for example limits communication speed to 20kBd or less. Connect a LIN transceiver or other UART connections such as RS-232 and RS-485 directly to the MAXQ7667's 2-wire interface: URX and UTX. The MAXQ7667 operates as a LIN slave or LIN master device. The UART provides the programmable baud-rate generators to communicate effectively to or from the LIN transceiver. The device holds up to 8 bytes of data in each of the transmit and receive FIFOs. The following characteristics apply to the MAXQ7667 UART/LIN interface:

- Full-duplex operation for asynchronous data transfers up to 500kBd (system clock/32)
- Half-duplex operation for synchronous data transfers up to 2MBd (system clock/8)
- 8-deep receive and transmit FIFO with programmable interrupt for receive and transmit
- Independent baud-rate generator
- Programmable 9th data bit (commonly used for parity or address/data selection)—UART mode only
- Hardware support for LIN including break detection, autobaud, address identity filtering, checksum calculation, and block length checking

- Supports common RS-232 and LIN baud rates: 1000, 1200, 2400, 4800, 9600, 19,200, 20,000, 38,400, 57,600, and 115,200 with system clock = 16MHz.

SPI Interface

The MAXQ7667 supports 4-wire SPI interface communication with 8-bit or 16-bit data streams operating in either master mode or slave mode. The SPI interface allows synchronous half-duplex or full-duplex serial data transfers to a wide variety of external serial devices using MISO, MOSI, SS, and SCLK signals. Collision detection is provided when two or more masters attempt a data transfer at the same time. See Section 9 of the *MAXQ7667 User's Guide*.

General-Purpose Digital I/O Ports

Two 8-bit digital I/O ports (P0._ and P1._), with dedicated one or more alternative functions, are available as general-purpose I/Os (GPIOs) under the control of the integrated MAXQ20. Set each I/O within each port individually as an input or output. The GPIOs incorporate a Schmitt trigger receiver and a full CMOS output driver (Figure 13). Each GPIO configures as an input with pullup to DVDDIO at power-up. When programmed as an input, each I/O is configurable for high-impedance, weak pullup to DVDDIO or pulldown to DGND. When programmed as an output, writing to the port output register (PO) controls the output logic state. The outputs source or sink at least 1.6mA. Configure the drive strength for each I/O within each port to high or low using the pad drive strength register for optimum EMI performance. All the I/O ports have interrupt capability that wake up the device while in stop mode and have protection circuitry to DVDDIO and DGND.

Supply-Voltage Regulators

The MAXQ7667 requires three different power-supply voltages. DVDDIO, nominally +5V, allows interfacing to standard 5V logic on all the digital I/Os including the LIN/UART, JTAG, and SPI ports. DVDD, nominally +2.5V, powers all the high-speed digital circuits. AVDD, nominally 3.3V, powers the analog circuits.

External power supplies or internal voltage regulators provide each of the supply voltages. The internal voltage regulators provide 3.3V and 2.5V supplies from the 5V DVDDIO input. Obtain the 5V supply from a higher external voltage supply by using a few external components. The MAXQ7667 includes an internal error amplifier used to regulate the voltage on DVDDIO by driving the gate or base of an external pass transistor. Refer to the *MAXQ7667 User's Guide* for more details on the external components needed for 5V regulation.

16-Bit, RISC, Microcontroller-Based, Ultrasonic Distance-Measuring System

MAXQ7667

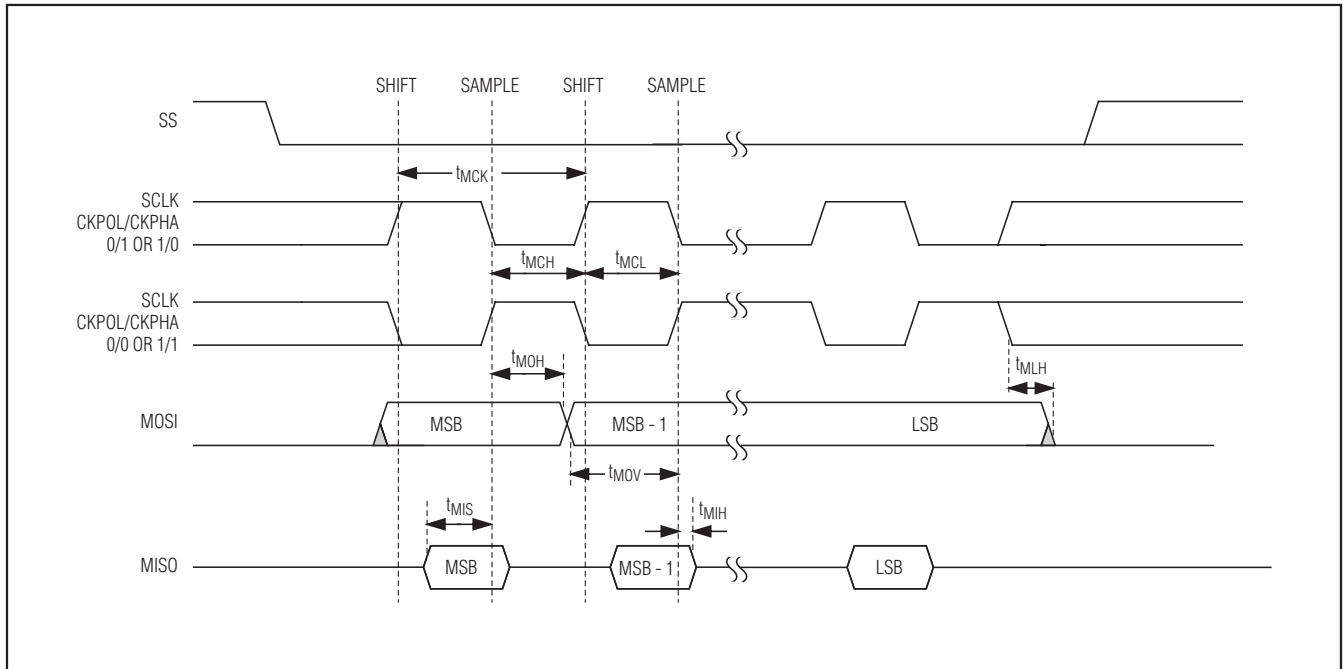

Figure 11. SPI Timing Diagram in Master Mode

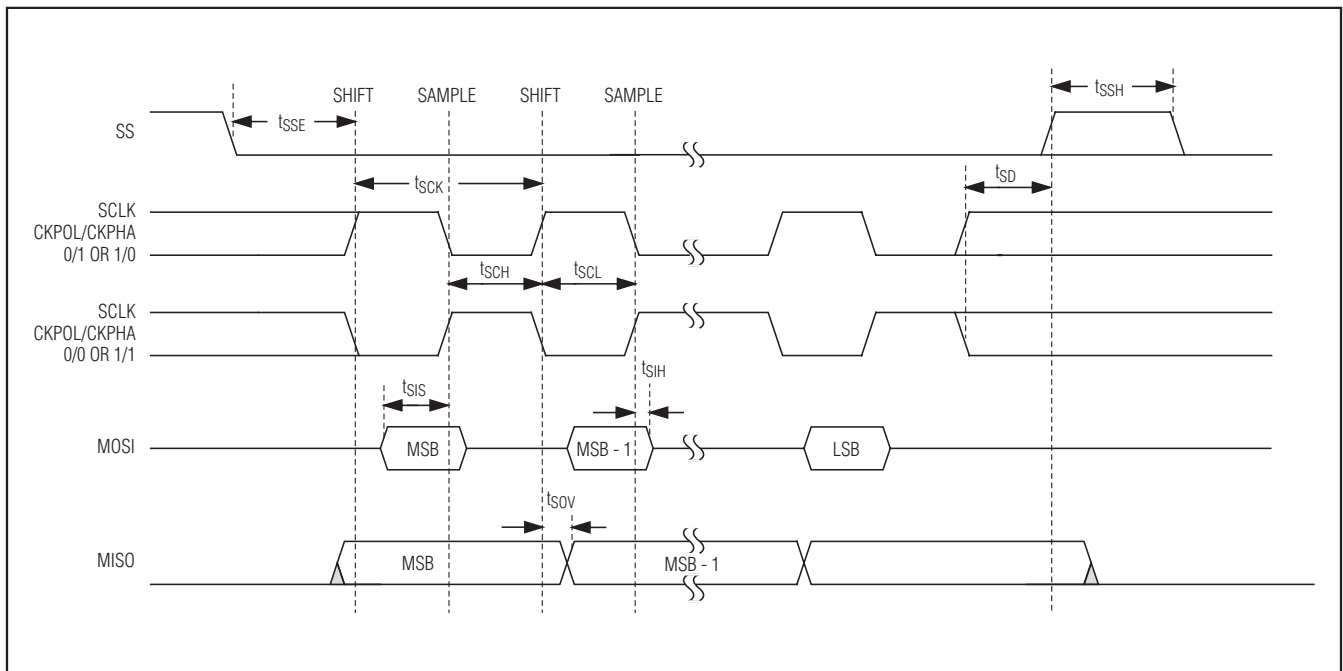

Figure 12. SPI Timing Diagram in Slave Mode

16-Bit, RISC, Microcontroller-Based, Ultrasonic Distance-Measuring System

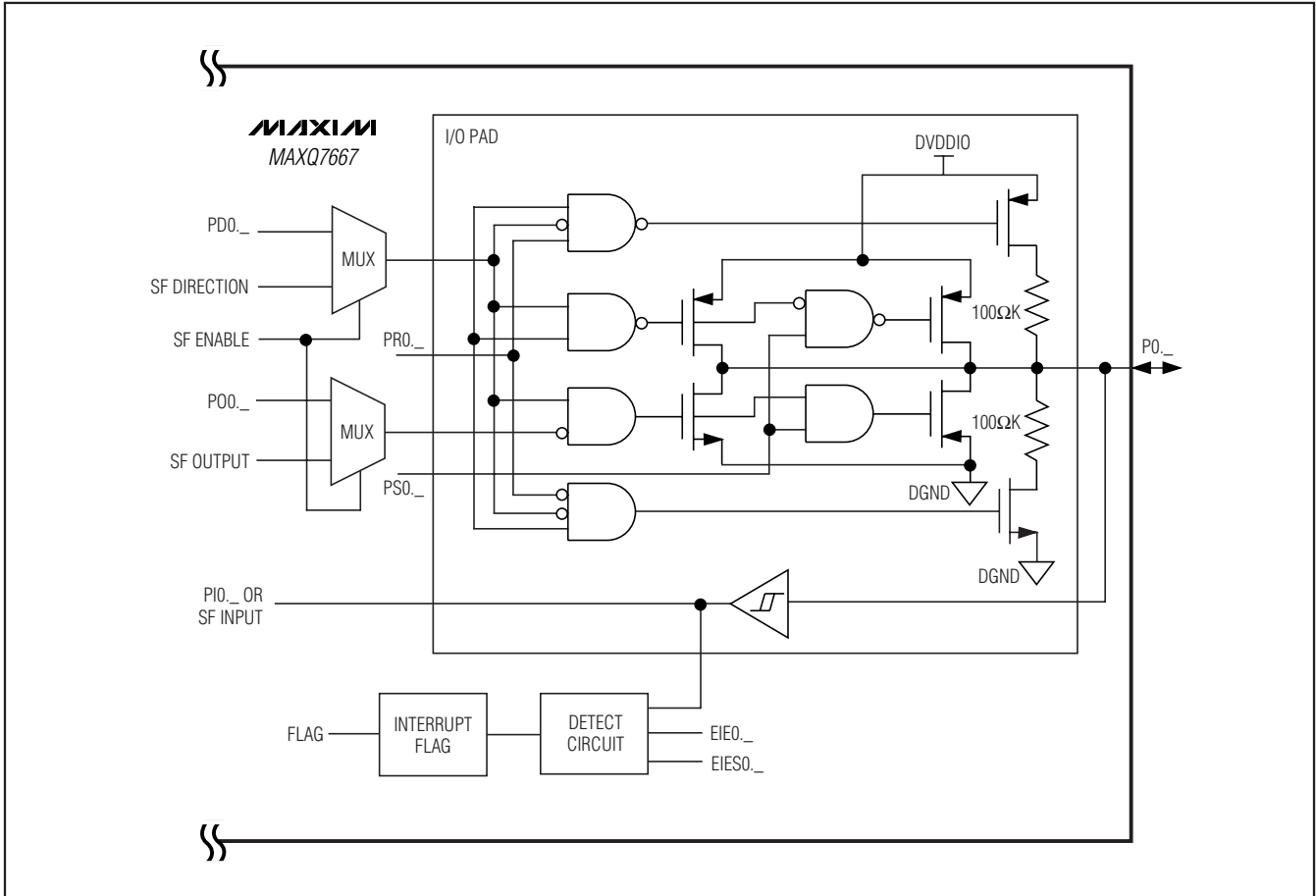

Figure 13. Port 0 Digital I/O Basic Circuitry. Port 1 Circuitry is the Same as Port 2.

Connect bypass capacitors at each power-supply input as close as possible to the device. Use a bypass capacitor less than 0.47µF on DVDDIO. For most applications, 0.1µF bypass capacitors are adequate.

Supply Brownout Monitor

Power supplies DVDD, AVDD, and DVDDIO each include a brownout monitor/supervisor that alerts the µC when their corresponding supply voltages drop below the interrupt threshold. Activate each brownout monitor independently using the corresponding brownout enable bits: VDBE, VIBE, and VABE.

Reset

In reset mode, no instruction execution occurs and all inputs/outputs return to their default states. Code execution resumes at address 8000h (in the utility ROM) once the reset condition is removed.

Four different sources reset the MAXQ7667: POR, watchdog timer reset, external reset, and internal system reset.

During normal operation, force $\overline{\text{RESET}}$ low for at least four system clock cycles for an external reset. Set the ROD bit in the SC register, while the SPE bit in the ICDF register is set, for an internal system reset. See Section 16 of the *MAXQ7667 User's Guide*.

Power-On Reset (POR)

The MAXQ7667 includes a DVDD voltage supervisor to control the µC POR. On power-up, internal circuitry pulls $\overline{\text{RESET}}$ low and resets all the internal registers. $\overline{\text{RESET}}$ is held low for the duration of the power-on delay after VDvDD rises above the DVDD reset threshold. The internal RC oscillator starts up and software execution begins at the reset vector location 8000h immediately after the device exits POR while $\overline{\text{RESET}}$ is

16-Bit, RISC, Microcontroller-Based, Ultrasonic Distance-Measuring System

not externally forced low. An internal POR flag indicates the source of a reset. Ramp up the DVDD supply at a minimum rate of 60mV/ms to keep the device in POR until DVDD fully settles.

Watchdog Timer

The primary function of the watchdog timer is to watch for stalled or stuck software. The watchdog timer performs a controlled system restart when the μ P fails to write to the watchdog timer register before a selectable timeout interval expires. The internal 13.5MHz RC oscillator drives the MAXQ7667's watchdog timer.

Figure 14 shows the watchdog timer functions as the source of both the watchdog interrupt and watchdog reset. The watchdog interrupt timeout period is programmable to 2^{12} , 2^{15} , 2^{18} , or 2^{21} cycles of the RC oscillator resulting in a nominal range of 273 μ s to 139.8ms. The watchdog reset timeout period is a fixed 512 RC clock cycles (34 μ s). When enabled, the watchdog generates an interrupt upon expiration; then, if not reset within 512 RC clock cycles, the watchdog asserts $\overline{\text{RESET}}$ low for eight RC clock cycles.

Hardware Multiplier/Accumulator

A hardware multiplier supports high-speed multiplications. The multiplier completes a 16-bit x 16-bit multiplication in a single clock cycle and contains a 48-bit accumulator. The multiplier is a peripheral that performs seven different multiplication operations:

- Unsigned 16-bit multiplication
- Unsigned 16-bit multiplication and accumulation
- Unsigned 16-bit multiplication and subtraction

- Signed 16-bit multiplication
- Signed 16-bit multiplication and negation
- Signed 16-bit multiplication and accumulation
- Signed 16-bit multiplication and subtraction

MAXQ Core Architecture

The MAXQ20 μ C is an accumulator-based Harvard memory architecture. Fetch and execution operations complete in one clock cycle without pipelining because the instruction contains both the op code and data. The μ C streamlines 16 million instructions per second (MIPS). Integrated 16-level hardware stack enables fast subroutine calling and task switching. Manipulate data quickly and efficiently with three internal data pointers. Multiple data pointers allow more than one function to access data memory without having to save and restore data pointers each time. The data pointers automatically increment or decrement following an operation, eliminating the need for software intervention.

Instruction Set

The instruction set consists of a total of 33 fixed-length 16-bit instructions that operate on registers and memory locations. The highly orthogonal instruction set allows arithmetic and logical operations to use any register along with the accumulator. System registers control functionality common to all MAXQ μ Cs, while peripheral registers control peripherals and functions specific to the MAXQ7667. All registers are subdivided into register modules.

The architecture is transport-triggered. Writes or reads from certain register locations potentially have side effects. These side effects form the basis for the higher level op codes defined by the assembler, such as ADDC, OR, JUMP, etc. The op codes are implemented as MOVE instructions between system registers. The assembler handles all the instruction encoding.

Memory Organization

In addition to the internal register space, the device incorporates several memory areas:

- 16Kwords of flash memory for program storage
- 2Kword of SRAM for storage of temporary variables
- 4Kwords utility ROM
- 16-level, 16-bit-wide hardware stack for storage of program return addresses and general-purpose use

Use the internal memory-management unit (MMU) to map data memory space into a predefined program memory segment for code execution from data memory. Use the MMU to map program memory space as data space for access to constant data stored in program

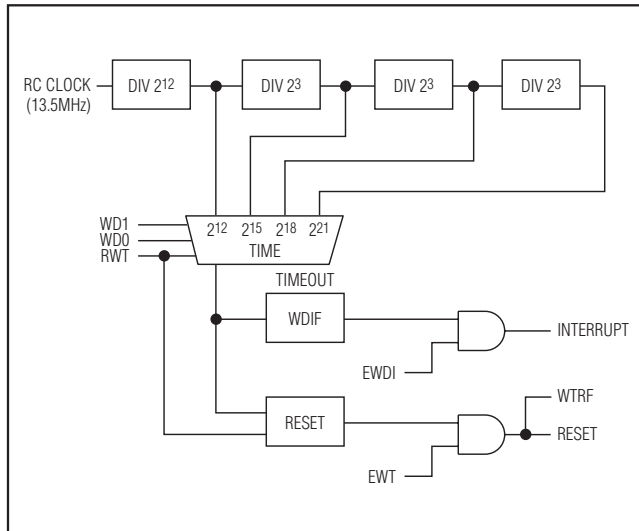

Figure 14. Watchdog Functional Diagram

16-Bit, RISC, Microcontroller-Based, Ultrasonic Distance-Measuring System

memory. Access physical memory segments (other than the stack and register memories) as either program memory or data memory, but not both at once.

By default, the memory is arranged in a Harvard architecture, with separate address spaces for program and data memory. The configuration of program and data space depends on the current execution location.

- When executing code from flash memory, access the SRAM and utility ROM in data space.
- When executing code from SRAM, access the flash memory and utility ROM in data space.
- When executing code from the utility ROM, access the flash memory and SRAM in data space.

Utility ROM (see Section 18 of the MAXQ7667 User's Guide)

The utility ROM is a 4K x 16 block of internal ROM memory that defaults to a starting address of 8000h. The utility ROM consists of subroutines called from application software. The subroutines include:

- In-system programming (bootloader) over the JTAG or UART interface
- In-circuit debug routines
- Test routines (internal memory tests, memory loader, etc.)
- User-callable routines for in-application flash programming and code space table lookup

Following any reset, execution begins in the utility ROM. The ROM software determines whether the program execution immediately jumps to the start of the user-application code (located at address 0000h) or to one of the special routines mentioned above. Call the routines within the utility ROM using the application software. Refer to the *MAXQ7667 User's Guide* for more information on the utility ROM contents.

Password protect in-system programming, in-application programming, and in-circuit debugging functions using a password-lock (PWL) bit. The PWL bit is implemented in the SC register. When the PWL bit is set to one (POR default), the password is required to access the utility ROM, including in-circuit debug and in-system programming routines that allow reading or writing of internal memory. When the PWL bit is cleared to zero, these utilities are fully accessible without the password. The password is automatically set to all ones following a mass erase.

Data Memory

The 2K x 16 internal data SRAM maps into either program or data space. The contents of the SRAM are maintained during stop mode and across non-POR resets, as long as DVDD remains within the operating voltage range.

A data memory cycle requires only one system clock period to support fast internal execution. This allows a complete read or write operation on SRAM in one clock cycle. The MMU handles data memory mapping and access control. Read or write to the data memory with word or byte-wide commands.

Stack Memory

The MAXQ7667 provides a 16 x 16 hardware stack to support subroutine calls and system interrupts. A 16-bit wide internal hardware stack provides storage for program return addresses and general-purpose use. The stack is used automatically by the processor when the CALL, RET, and RETI instructions are executed and interrupts serviced.

Register Set

Sets of registers control most functions. These registers provide a working space for memory operations as well as configuring and addressing peripheral registers on the device. Registers are divided into two major types; system registers and peripheral registers. The register set common to most MAXQ-based devices, also known as the system registers, includes the ALU, accumulator registers, data pointers, interrupt vectors and control, and stack pointer. The peripheral registers define additional functionality. Tables 1 and 3 show the MAXQ7667 register set.

Programming

Two different methods program the flash memory: in-system programming and in-application programming. Both methods afford great flexibility in system design as well as reduce the life-cycle cost of the embedded system. The MAXQ7667 password protects these features to prevent unauthorized access to code memory.

In-System Programming

An internal bootstrap loader reloads the device over a simple JTAG or UART interface allowing cost savings in system software upgrade. During power-up, the MAXQ7667 first checks for activity on the JTAG port. If no activity is present, the device checks if a password-protected program is present. If the password is set,

16-Bit, RISC, Microcontroller-Based, Ultrasonic Distance-Measuring System

the application code executes. The application codes initiate reprogramming. If the password is not set, the MAXQ7667 monitors the UART for an autobaud character (0x0D). If this character is received, the device sets its serial baud rate and initiates a boot loader procedure. If 0x0D is not received after five seconds, the device begins execution of the application code.

The following bootloader functions are supported:

- Load
- Dump
- CRC
- Verify
- Erase

In-Application Programming

The in-application programming feature allows the μC to modify its own flash program memory while simultaneously executing its application software. This allows on the fly software updates in mission-critical applications that cannot afford downtime. Erase and program the flash memory using the flash programming functions in the utility ROM. Refer to Section 18 of the *MAXQ7667 User's Guide* for a detailed description of the utility ROM functions.

Stop Mode

Power consumption reaches its minimum in stop mode (STOP = 1). In this mode, the external oscillator, internal RC oscillator, system clock, and all processing halts. Trigger an enabled external interrupt input or directly apply an external reset on $\overline{\text{RESET}}$ to exit stop mode. Upon exiting stop mode, the μC either waits for the external high-frequency crystal to complete its warmup period or starts execution immediately from its internal RC oscillator while the crystal warms up.

Interrupts

Multiple interrupt sources quickly respond to internal and external events. The MAXQ architecture uses a single interrupt vector (IV) and single interrupt-service routine (ISR) design. Enable interrupts globally,

individually, or by module. When an interrupt condition occurs, its individual flag is set even if the interrupt source is disabled at the local, module, or global level. Clear interrupt flags within the interrupt routine to avoid repeated false interrupts from the same source. Provide an adequate delay between the write to the flag and the RETI instruction using application software to allow time for the interrupt hardware to remove the internal interrupt condition. Asynchronous interrupt flags require a one-instruction delay and synchronous interrupt flags require a two-instruction delay.

When an enabled interrupt is detected, software jumps to a user-programmable interrupt vector location. The IV register defaults to 0000h on reset or power-up. Once software control transfers to the ISR, use the interrupt identification register (IIR) to determine if the source of the interrupt is a system register or peripheral register. The specified module identifies the specific interrupt source. The following interrupt sources are available:

- Watchdog interrupt
- External interrupts 0–7 on port 0 and port 1
- Timer 0 low compare, low overflow, capture/compare, and overflow interrupts
- Timer 1 low compare, low overflow, capture/compare, and overflow interrupts
- Timer 2 low compare, low overflow, and overflow interrupts
- Schedule timer alarm interrupt
- SPI data transfer complete, mode fault, write collision and receive overrun interrupts
- UART transmit, receive interrupts
- LIN mode master or slave interrupt
- SAR ADC data ready interrupt
- Echo envelope LPF output, FIFO full, and comparator interrupts
- Digital and I/O voltage brownout interrupts
- High-frequency oscillator failure interrupt

16-Bit, RISC, Microcontroller-Based, Ultrasonic Distance-Measuring System

Table 1. System Register Map

| REGISTER INDEX | MODULE NAME (BASE SPECIFIER) | | | | | | |
|----------------|------------------------------|--------------|---------------|-----------|--------------|-------------|--------------|
| | AP (8h) | A (9h) | PFX (Bh) | IP (Ch) | SP (Dh) | DPC (Eh) | DP (Fh) |
| 0h | AP | A[0] | PFX[0] | IP | — | — | — |
| 1h | APC | A[1] | PFX[1] | — | SP | — | — |
| 2h | — | A[2] | PFX[2] | — | IV | — | — |
| 3h | — | A[3] | PFX[3] | — | — | OFFS | DP[0] |
| 4h | PSF | A[4] | PFX[4] | — | — | DPC | — |
| 5h | IC | A[5] | PFX[5] | — | — | GR | — |
| 6h | IMR | A[6] | PFX[6] | — | LC[0] | GRL | — |
| 7h | — | A[7] | PFX[7] | — | LC[1] | BP | DP[1] |
| 8h | SC | A[8] | — | — | — | GRS | — |
| 9h | — | A[9] | — | — | — | GRH | — |
| Ah | — | A[10] | — | — | — | GRXL | — |
| Bh | <i>IIR</i> | A[11] | — | — | — | FP | — |
| Ch | — | A[12] | — | — | — | — | — |
| Dh | — | A[13] | — | — | — | — | — |
| Eh | CKCN | A[14] | — | — | — | — | — |
| Fh | WDCN | A[15] | — | — | — | — | — |

Note: Registers in italics are read-only. Registers in bold are 16-bit wide.

16-Bit, RISC, Microcontroller-Based, Ultrasonic Distance-Measuring System

Table 2. System Register Bit and Reset Values

| REGISTER | REGISTER BIT | | | | | | | | | | | | | | | | | |
|---------------|--------------|----|----|----|----|----|---|------------------|------|------|------|------|-------------|------|------|---|---|---|
| | 15 | 14 | 13 | 12 | 11 | 10 | 9 | 8 | 7 | 6 | 5 | 4 | 3 | 2 | 1 | 0 | | |
| AP | | | | | | | | — | — | — | — | — | AP (4 Bits) | | | | | |
| APC | | | | | | | | CLR | IDS | — | — | — | MOD2 | MOD1 | MOD0 | | | |
| PSF | | | | | | | | Z | S | — | GPF1 | GPF0 | OV | C | E | | | |
| IC | | | | | | | | 1 | 0 | 0 | 0 | 0 | 0 | 0 | 0 | | | |
| IMR | | | | | | | | — | — | CGDS | — | — | — | INS | IGE | | | |
| SC | | | | | | | | IMS | — | IM5 | IM4 | IM3 | IM2 | IM1 | IM0 | | | |
| IIR | | | | | | | | TAP | — | CDA1 | CDA0 | — | ROD | PWL | — | | | |
| CKCN | | | | | | | | 1 | 0 | 0 | 0 | 0 | 0 | 0 | 0 | | | |
| | | | | | | | | IIS | — | IIS | IIS | IIS | IIS | IIS | IIS | | | |
| | | | | | | | | XTRC | — | RGMD | STOP | SWB | PMME | CD1 | CD0 | | | |
| WDCN | | | | | | | | S* | 0 | 0 | 0 | 0 | 0 | 0 | 0 | | | |
| | | | | | | | | POR | EWDI | WD1 | WD0 | WDIF | WTRF | EWT | RWT | | | |
| A[n] (0..15) | 0 | 0 | 0 | 0 | 0 | 0 | 0 | S* | S* | 0 | 0 | 0 | 0 | S* | 0 | | | |
| PFX[n] (0..7) | 0 | 0 | 0 | 0 | 0 | 0 | 0 | A[n] (16 Bits) | | | | | | | | 0 | 0 | 0 |
| IP | 1 | 0 | 0 | 0 | 0 | 0 | 0 | PFX[n] (16 Bits) | | | | | | | | 0 | 0 | 0 |
| | — | — | — | — | — | — | — | IP (16 Bits) | | | | | | | | 0 | 0 | 0 |
| SP | 0 | 0 | 0 | 0 | 0 | 0 | 0 | IV (16 Bits) | | | | | | | | 1 | 1 | 1 |
| | — | — | — | — | — | — | — | IV (16 Bits) | | | | | | | | 0 | 0 | 0 |
| IV | 0 | 0 | 0 | 0 | 0 | 0 | 0 | LC[0] (16 Bits) | | | | | | | | 0 | 0 | 0 |
| | — | — | — | — | — | — | — | LC[0] (16 Bits) | | | | | | | | 0 | 0 | 0 |
| LC[0] | 0 | 0 | 0 | 0 | 0 | 0 | 0 | LC[1] (16 Bits) | | | | | | | | 0 | 0 | 0 |
| | — | — | — | — | — | — | — | LC[1] (16 Bits) | | | | | | | | 0 | 0 | 0 |
| LC[1] | 0 | 0 | 0 | 0 | 0 | 0 | 0 | SP (4 Bits) | | | | | | | | 1 | 1 | 1 |
| | — | — | — | — | — | — | — | SP (4 Bits) | | | | | | | | 0 | 0 | 0 |

*Bits indicated by an "s" are only affected by a POR and not by other forms of reset. These bits are set to 0 after a POR. Refer to the MAXQ7667 User's Guide for more information.

16-Bit, RISC, Microcontroller-Based, Ultrasonic Distance-Measuring System

Table 2. System Register Bit and Reset Values (continued)

| REGISTER | REGISTER BIT | | | | | | | | | | | | | | | |
|----------|-----------------|--------|--------|--------|--------|--------|-------|-------|-------|-------|-------|---------------|-------|-------|-------|-------|
| | 15 | 14 | 13 | 12 | 11 | 10 | 9 | 8 | 7 | 6 | 5 | 4 | 3 | 2 | 1 | 0 |
| OFFS | | | | | | | | | | | | OFFS (8 Bits) | | | | |
| | | | | | | | | | 0 | 0 | 0 | 0 | 0 | 0 | 0 | 0 |
| DPC | | | | | | | | | | | | WBS2 | WBS1 | WBS0 | SDPS1 | SDPS0 |
| | 0 | 0 | 0 | 0 | 0 | 0 | 0 | 0 | 0 | 0 | 0 | 1 | 1 | 1 | 0 | 0 |
| GR | GR15 | GR14 | GR13 | GR12 | GR11 | GR10 | GR9 | GR8 | GR7 | GR6 | GR5 | GR4 | GR3 | GR2 | GR1 | GR0 |
| | 0 | 0 | 0 | 0 | 0 | 0 | 0 | 0 | 0 | 0 | 0 | 0 | 0 | 0 | 0 | 0 |
| GRL | | | | | | | | | GRL7 | GRL6 | GRL5 | GRL4 | GRL3 | GRL2 | GRL1 | GRL0 |
| | | | | | | | | | 0 | 0 | 0 | 0 | 0 | 0 | 0 | 0 |
| BP | BP (16 Bits) | | | | | | | | | | | | | | | |
| GRS | 0 | 0 | 0 | 0 | 0 | 0 | 0 | 0 | 0 | 0 | 0 | 0 | 0 | 0 | 0 | 0 |
| | GRS15 | GRS14 | GRS13 | GRS12 | GRS11 | GRS10 | GRS9 | GRS8 | GRS7 | GRS6 | GRS5 | GRS4 | GRS3 | GRS2 | GRS1 | GRS0 |
| GRH | 0 | 0 | 0 | 0 | 0 | 0 | 0 | 0 | 0 | 0 | 0 | 0 | 0 | 0 | 0 | 0 |
| | | | | | | | | | GR15 | GR14 | GR13 | GR12 | GR11 | GR10 | GR9 | GR8 |
| GRXL | GRXL15 | GRXL14 | GRXL13 | GRXL12 | GRXL11 | GRXL10 | GRXL9 | GRXL8 | GRXL7 | GRXL6 | GRXL5 | GRXL4 | GRXL3 | GRXL2 | GRXL1 | GRXL0 |
| | 0 | 0 | 0 | 0 | 0 | 0 | 0 | 0 | 0 | 0 | 0 | 0 | 0 | 0 | 0 | 0 |
| FP | FP (16 Bits) | | | | | | | | | | | | | | | |
| DP[0] | 0 | 0 | 0 | 0 | 0 | 0 | 0 | 0 | 0 | 0 | 0 | 0 | 0 | 0 | 0 | 0 |
| | DP[0] (16 Bits) | | | | | | | | | | | | | | | |
| DP[1] | 0 | 0 | 0 | 0 | 0 | 0 | 0 | 0 | 0 | 0 | 0 | 0 | 0 | 0 | 0 | 0 |
| | DP[1] (16 Bits) | | | | | | | | | | | | | | | |

*Bits indicated by an "s" are only affected by a POR and not by other forms of reset. These bits are set to 0 after a POR. Refer to the MAXQ7667 User's Guide for more information.

16-Bit, RISC, Microcontroller-Based, Ultrasonic Distance-Measuring System

MAXQ7667

Table 3. Peripheral Register Map

| REGISTER INDEX | MODULE NAME (BASE SPECIFIER) | | | | | |
|----------------|------------------------------|---------|---------|---------|---------|---------|
| | M0 (0h) | M1 (1h) | M2 (2h) | M3 (3h) | M4 (4h) | M5 (5h) |
| 0h | PO0 | MCNT | T2CNA0 | T2CNA2 | — | BPH |
| 1h | PO1 | MA | T2H0 | T2H2 | — | BTRN |
| 2h | — | MB | T2RH0 | T2RH2 | — | SARC |
| 3h | EIF0 | MC2 | T2CH0 | T2CH2 | — | RCVC |
| 4h | EIF1 | MC1 | T2CNA1 | — | — | PLL |
| 5h | — | MC0 | T2H1 | CNT1 | — | AIE |
| 6h | — | SPIB | T2RH1 | SCON | — | CMPC |
| 7h | — | SPICN | T2CH1 | SBUF | — | CMPT |
| 8h | PI0 | SPICF | T2CNB0 | T2CNB2 | — | ASR |
| 9h | PI1 | SPICK | T2V0 | T2V2 | — | SARD |
| Ah | — | — | T2R0 | T2R2 | — | LPFC |
| Bh | EIE0 | — | T2C0 | T2C2 | — | OSCC |
| Ch | EIE1 | MC1R | T2CNB1 | FSTAT | — | BPFI |
| Dh | — | MC0R | T2V1 | ERRR | — | BPFO |
| Eh | — | SCNT | T2R1 | CHKSUM | — | LPFD |
| Fh | — | STIM | T2C1 | ISVEC | — | LPFF |
| 10h | PDO | SALM | T2CFG0 | T2CFG2 | — | APE |
| 11h | PD1 | FPCTL | T2CFG1 | STA0 | — | — |
| 12h | — | — | — | SMD | — | FGAIN |
| 13h | EIES0 | — | — | FCON | — | B1COEF |
| 14h | EIES1 | — | — | CNT0 | — | B2COEF |
| 15h | — | — | — | CNT2 | — | B3COEF |
| 16h | — | — | — | IDFB | — | A2A |
| 17h | — | RCTRM | — | SADDR | — | A2B |
| 18h | PS0 | — | ICDT0 | SADEN | — | — |
| 19h | PS1 | — | ICDT1 | BT | — | A2D |
| 1Ah | — | — | ICDC | TMR | — | — |
| 1Bh | PR0 | — | ICDF | — | — | A3A |
| 1Ch | PR1 | ID0 | ICDB | — | — | A3B |
| 1Dh | — | ID1 | ICDA | — | — | — |
| 1Eh | — | — | ICDD | — | — | A3D |
| 1Fh | — | — | — | — | — | — |

16-Bit, RISC, Microcontroller-Based, Ultrasonic Distance-Measuring System

Table 4. Peripheral Register Bit Functions and Reset Values

| REGISTER | 15 | 14 | 13 | 12 | 11 | 10 | 9 | 8 | REGISTER BIT | | | | | | | | 0 |
|----------|--------|--------|--------|--------|--------|--------|-------|-------|--------------|--------|--------|--------|--------|--------|--------|--------|---|
| | | | | | | | | | 7 | 6 | 5 | 4 | 3 | 2 | 1 | | |
| PO0 | 0 | 0 | 0 | 0 | 0 | 0 | 0 | 0 | PO07 | PO06 | PO05 | PO04 | PO03 | PO02 | PO01 | PO00 | |
| PO1 | 0 | 0 | 0 | 0 | 0 | 0 | 0 | 0 | PO17 | PO16 | PO15 | PO14 | PO13 | PO12 | PO11 | PO10 | |
| EiF0 | 0 | 0 | 0 | 0 | 0 | 0 | 0 | 0 | IE7 | IE6 | IE5 | IE4 | IE3 | IE2 | IE1 | IE0 | |
| EiF1 | 0 | 0 | 0 | 0 | 0 | 0 | 0 | 0 | IE7 | IE6 | IE5 | IE4 | IE3 | IE2 | IE1 | IE0 | |
| PI0 | 0 | 0 | 0 | 0 | 0 | 0 | 0 | 0 | PI07 | PI06 | PI05 | PI04 | PI03 | PI02 | PI01 | PI00 | |
| PI1 | 0 | 0 | 0 | 0 | 0 | 0 | 0 | 0 | ST | ST | ST | ST | ST | ST | ST | ST | |
| EiE0 | 0 | 0 | 0 | 0 | 0 | 0 | 0 | 0 | EX7 | EX6 | EX5 | EX4 | EX3 | EX2 | EX1 | EX0 | |
| EiE1 | 0 | 0 | 0 | 0 | 0 | 0 | 0 | 0 | EX7 | EX6 | EX5 | EX4 | EX3 | EX2 | EX1 | EX0 | |
| PD0 | 0 | 0 | 0 | 0 | 0 | 0 | 0 | 0 | PD07 | PD06 | PD05 | PD04 | PD03 | PD02 | PD01 | PD00 | |
| PD1 | 0 | 0 | 0 | 0 | 0 | 0 | 0 | 0 | PD17 | PD16 | PD15 | PD14 | PD13 | PD12 | PD11 | PD10 | |
| EiES0 | 0 | 0 | 0 | 0 | 0 | 0 | 0 | 0 | IT7 | IT6 | IT5 | IT4 | IT3 | IT2 | IT1 | IT0 | |
| EiES1 | 0 | 0 | 0 | 0 | 0 | 0 | 0 | 0 | IT7 | IT6 | IT5 | IT4 | IT3 | IT2 | IT1 | IT0 | |
| PS0 | 0 | 0 | 0 | 0 | 0 | 0 | 0 | 0 | PS07 | PS06 | PS05 | PS04 | PS03 | PS02 | PS01 | PS00 | |
| PS1 | 0 | 0 | 0 | 0 | 0 | 0 | 0 | 0 | PS17 | PS16 | PS15 | PS14 | PS13 | PS12 | PS11 | PS10 | |
| PR0 | 0 | 0 | 0 | 0 | 0 | 0 | 0 | 0 | PR07 | PR06 | PR05 | PR04 | PR03 | PR02 | PR01 | PR00 | |
| PR1 | 0 | 0 | 0 | 0 | 0 | 0 | 0 | 0 | PR17 | PR16 | PR15 | PR14 | PR13 | PR12 | PR11 | PR10 | |
| MCNT | 0 | 0 | 0 | 0 | 0 | 0 | 0 | 0 | OF | MCW | CLD | SOU | OPCS | MSUB | MMAC | SUS | |
| MA | MA15 | MA14 | MA13 | MA12 | MA11 | MA10 | MA9 | MA8 | MA7 | MA6 | MA5 | MA4 | MA3 | MA2 | MA1 | MA0 | |
| MB | MB15 | MB14 | MB13 | MB12 | MB11 | MB10 | MB9 | MB8 | MB7 | MB6 | MB5 | MB4 | MB3 | MB2 | MB1 | MB0 | |
| MC2 | MC215 | MC214 | MC213 | MC212 | MC211 | MC210 | MC29 | MC28 | MC27 | MC26 | MC25 | MC24 | MC23 | MC22 | MC21 | MC20 | |
| MC1 | MC115 | MC114 | MC113 | MC112 | MC111 | MC110 | MC19 | MC18 | MC17 | MC16 | MC15 | MC14 | MC13 | MC12 | MC11 | MC10 | |
| MC0 | MC015 | MC014 | MC013 | MC012 | MC011 | MC010 | MC09 | MC08 | MC07 | MC06 | MC05 | MC04 | MC03 | MC02 | MC01 | MC00 | |
| SPIB | SPIB15 | SPIB14 | SPIB13 | SPIB12 | SPIB11 | SPIB10 | SPIB9 | SPIB8 | SPIB7 | SPIB6 | SPIB5 | SPIB4 | SPIB3 | SPIB2 | SPIB1 | SPIB0 | |
| SPICN | 0 | 0 | 0 | 0 | 0 | 0 | 0 | 0 | STBY | SPIC | ROVR | WCOL | MODF | MODFE | MSTM | SPIEN | |
| SPICF | 0 | 0 | 0 | 0 | 0 | 0 | 0 | 0 | ESPII | SAS | — | — | — | CHR | CKPHA | CKPOL | |
| SPICK | 0 | 0 | 0 | 0 | 0 | 0 | 0 | 0 | SPICK7 | SPICK6 | SPICK5 | SPICK4 | SPICK3 | SPICK2 | SPICK1 | SPICK0 | |
| FCNTL | 0 | 0 | 0 | 0 | 0 | 0 | 0 | 0 | FBUSY | — | — | — | — | FC2 | FC1 | FC0 | |
| MC1R | MC1R15 | MC1R14 | MC1R13 | MC1R12 | MC1R11 | MC1R10 | MC1R9 | MC1R8 | MC1R7 | MC1R6 | MC1R5 | MC1R4 | MC1R3 | MC1R2 | MC1R1 | MC1R0 | |
| MC0R | MC0R15 | MC0R14 | MC0R13 | MC0R12 | MC0R11 | MC0R10 | MC0R9 | MC0R8 | MC0R7 | MC0R6 | MC0R5 | MC0R4 | MC0R3 | MC0R2 | MC0R1 | MC0R0 | |

16-Bit, RISC, Microcontroller-Based, Ultrasonic Distance-Measuring System

MAXQ7667

Table 4. Peripheral Register Bit Functions and Reset Values (continued)

| REGISTER | REGISTER BIT | | | | | | | | | | | | | | | |
|----------|--------------|---------|---------|---------|---------|---------|--------|--------|--------|--------|--------|--------|--------|--------|--------|--------|
| | 15 | 14 | 13 | 12 | 11 | 10 | 9 | 8 | 7 | 6 | 5 | 4 | 3 | 2 | 1 | 0 |
| SCNT | — | — | — | — | — | — | — | — | — | — | — | — | — | — | — | — |
| STIM | STIM15 | STIM14 | STIM13 | STIM12 | STIM11 | STIM10 | STIM9 | STIM8 | STIM7 | STIM6 | STIM5 | STIM4 | STIM3 | STIM2 | STIM1 | STIM0 |
| SALM | SALM15 | SALM14 | SALM13 | SALM12 | SALM11 | SALM10 | SALM9 | SALM8 | SALM7 | SALM6 | SALM5 | SALM4 | SALM3 | SALM2 | SALM1 | SALM0 |
| FPCNTL | — | — | — | — | — | — | — | — | — | — | — | — | — | — | — | DPMG |
| RCTRM | — | — | — | — | — | — | — | RCTRM8 | RCTRM7 | RCTRM6 | RCTRM5 | RCTRM4 | RCTRM3 | RCTRM2 | RCTRM1 | RCTRM0 |
| ID0 | ID015 | ID014 | ID013 | ID012 | ID011 | ID010 | ID09 | ID08 | ID07 | ID06 | ID05 | ID04 | ID03 | ID02 | ID01 | ID00 |
| ID1 | ID115 | ID114 | ID113 | ID112 | ID111 | ID110 | ID19 | ID18 | ID17 | ID16 | ID15 | ID14 | ID13 | ID12 | ID11 | ID10 |
| T2CNA0 | — | — | — | — | — | — | — | — | ET2 | T2OE0 | T2POL0 | TR2L | TR2 | CPRL2 | SS2 | G2EN |
| T2H0 | — | — | — | — | — | — | — | — | T2H07 | T2H06 | T2H05 | T2H04 | T2H03 | T2H02 | T2H01 | T2H00 |
| T2RH0 | — | — | — | — | — | — | — | — | T2RH07 | T2RH06 | T2RH05 | T2RH04 | T2RH03 | T2RH02 | T2RH01 | T2RH00 |
| T2CH0 | — | — | — | — | — | — | — | — | T2CH07 | T2CH06 | T2CH05 | T2CH04 | T2CH03 | T2CH02 | T2CH01 | T2CH00 |
| T2CNA1 | — | — | — | — | — | — | — | — | ET2 | T2OE0 | T2POL0 | TR2L | TR2 | CPRL2 | SS2 | G2EN |
| T2H1 | — | — | — | — | — | — | — | — | T2H17 | T2H16 | T2H15 | T2H14 | T2H13 | T2H12 | T2H11 | T2H10 |
| T2RH1 | — | — | — | — | — | — | — | — | T2RH17 | T2RH16 | T2RH15 | T2RH14 | T2RH13 | T2RH12 | T2RH11 | T2RH10 |
| T2CH1 | — | — | — | — | — | — | — | — | T2CH17 | T2CH16 | T2CH15 | T2CH14 | T2CH13 | T2CH12 | T2CH11 | T2CH10 |
| T2CNB0 | — | — | — | — | — | — | — | — | ET2L | T2OE1 | T2POL1 | — | TF2 | TF2L | TCC2 | TC2L |
| T2V0 | T2V015 | T2V014 | T2V013 | T2V012 | T2V011 | T2V010 | T2V09 | T2V08 | T2V07 | T2V06 | T2V05 | T2V04 | T2V03 | T2V02 | T2V01 | T2V00 |
| T2R0 | T2R015 | T2R014 | T2R013 | T2R012 | T2R011 | T2R010 | T2R09 | T2R08 | T2R07 | T2R06 | T2R05 | T2R04 | T2R03 | T2R02 | T2R01 | T2R00 |
| T2C0 | T2C015 | T2C014 | T2C013 | T2C012 | T2C011 | T2C010 | T2C09 | T2C08 | T2C07 | T2C06 | T2C05 | T2C04 | T2C03 | T2C02 | T2C01 | T2C00 |
| T2CNB1 | — | — | — | — | — | — | — | — | ET2L | T2OE1 | T2POL1 | — | TF2 | TF2L | TCC2 | TC2L |
| T2V1 | T2V115 | T2V114 | T2V113 | T2V112 | T2V111 | T2V110 | T2V19 | T2V18 | T2V17 | T2V16 | T2V15 | T2V14 | T2V13 | T2V12 | T2V11 | T2V10 |
| T2R1 | T2R115 | T2R114 | T2R113 | T2R112 | T2R111 | T2R110 | T2R19 | T2R18 | T2R17 | T2R16 | T2R15 | T2R14 | T2R13 | T2R12 | T2R11 | T2R10 |
| T2C1 | T2C115 | T2C114 | T2C113 | T2C112 | T2C111 | T2C110 | T2C19 | T2C18 | T2C17 | T2C16 | T2C15 | T2C14 | T2C13 | T2C12 | T2C11 | T2C10 |
| T2CFG0 | — | — | — | — | — | — | — | — | T2C1 | T2DM2 | T2DM1 | T2DM0 | T2MD | CCF1 | CCF0 | C72 |
| T2CFG1 | — | — | — | — | — | — | — | — | T2C1 | T2DM2 | T2DM1 | T2DM0 | T2MD | CCF1 | CCF0 | C72 |
| ICD10 | ICD1015 | ICD1014 | ICD1013 | ICD1012 | ICD1011 | ICD1010 | ICD109 | ICD108 | ICD107 | ICD106 | ICD105 | ICD104 | ICD103 | ICD102 | ICD101 | ICD100 |
| ICD11 | ICD1115 | ICD1114 | ICD1113 | ICD1112 | ICD1111 | ICD1110 | ICD119 | ICD118 | ICD117 | ICD116 | ICD115 | ICD114 | ICD113 | ICD112 | ICD111 | ICD110 |
| ICDC | — | — | — | — | — | — | — | — | DME | — | REG | — | CMD3 | CMD2 | CMD1 | CMD0 |
| | 0 | 0 | 0 | 0 | 0 | 0 | 0 | 0 | DW | 0 | DW | 0 | DW | DW | DW | DW |

16-Bit, RISC, Microcontroller-Based, Ultrasonic Distance-Measuring System

Table 4. Peripheral Register Bit Functions and Reset Values (continued)

| REGISTER | 15 | 14 | 13 | 12 | 11 | 10 | 9 | 8 | 7 | 6 | 5 | 4 | 3 | 2 | 1 | 0 |
|----------|----------|----------|----------|----------|----------|----------|---------|---------|---------|---------|---------|---------|---------|---------|---------|---------|
| ICDF | 0 | 0 | 0 | 0 | 0 | 0 | 0 | 0 | 0 | 0 | 0 | 0 | 0 | 0 | 0 | 0 |
| ICDB | 0 | 0 | 0 | 0 | 0 | 0 | 0 | 0 | 0 | 0 | 0 | 0 | 0 | 0 | 0 | 0 |
| ICDA | ICDA15 | ICDA14 | ICDA13 | ICDA12 | ICDA11 | ICDA10 | ICDA9 | ICDA8 | ICDA7 | ICDA6 | ICDA5 | ICDA4 | ICDA3 | ICDA2 | ICDA1 | ICDA0 |
| ICDD | ICDD15 | ICDD14 | ICDD13 | ICDD12 | ICDD11 | ICDD10 | ICDD9 | ICDD8 | ICDD7 | ICDD6 | ICDD5 | ICDD4 | ICDD3 | ICDD2 | ICDD1 | ICDD0 |
| T2CNA2 | 0 | 0 | 0 | 0 | 0 | 0 | 0 | 0 | ET2 | T2OE0 | T2POL0 | TR2L | TR2 | CPRL2 | SS2 | G2EN |
| T2H2 | 0 | 0 | 0 | 0 | 0 | 0 | 0 | 0 | T2H27 | T2H26 | T2H25 | T2H24 | T2H23 | T2H22 | T2H21 | T2H20 |
| T2RH2 | 0 | 0 | 0 | 0 | 0 | 0 | 0 | 0 | T2RH27 | T2RH26 | T2RH25 | T2RH24 | T2RH23 | T2RH22 | T2RH21 | T2RH20 |
| T2CH2 | 0 | 0 | 0 | 0 | 0 | 0 | 0 | 0 | T2CH27 | T2CH26 | T2CH25 | T2CH24 | T2CH23 | T2CH22 | T2CH21 | T2CH20 |
| CNT1 | 0 | 0 | 0 | 0 | 0 | 0 | 0 | 0 | RTN | CK | FL5 | FL4 | FL3 | FL2 | FL1 | FL0 |
| SCON | 0 | 0 | 0 | 0 | 0 | 0 | 0 | 0 | SMD/FE | SM1 | SM2 | REN | RB8 | RB8 | TI | RI |
| SBUF | 0 | 0 | 0 | 0 | 0 | 0 | 0 | 0 | SBUF7 | SBUF6 | SBUF5 | SBUF4 | SBUF3 | SBUF2 | SBUF1 | SBUF0 |
| T2CNB2 | 0 | 0 | 0 | 0 | 0 | 0 | 0 | 0 | ET2L | T2OE1 | T2POL1 | — | TF2 | TF2L | TCC2 | TC2L |
| T2V2 | T2V215 | T2V214 | T2V213 | T2V212 | T2V211 | T2V210 | T2V29 | T2V28 | T2V27 | T2V26 | T2V25 | T2V24 | T2V23 | T2V22 | T2V21 | T2V20 |
| T2R2 | T2R215 | T2R214 | T2R213 | T2R212 | T2R211 | T2R210 | T2R29 | T2R28 | T2R27 | T2R26 | T2R25 | T2R24 | T2R23 | T2R22 | T2R21 | T2R20 |
| T2C2 | T2C215 | T2C214 | T2C213 | T2C212 | T2C211 | T2C210 | T2C29 | T2C28 | T2C27 | T2C26 | T2C25 | T2C24 | T2C23 | T2C22 | T2C21 | T2C20 |
| FSTAT | 0 | 0 | 0 | 0 | 0 | 0 | 0 | 0 | — | — | TFF | TFAE | TFE | RFF | RFAF | RFE |
| ERRR | 0 | 0 | 0 | 0 | 0 | 0 | 0 | 0 | — | OTE | DME | CKE | P1 | PIE | P0 | POE |
| CHKSUM | CHKSUM15 | CHKSUM14 | CHKSUM13 | CHKSUM12 | CHKSUM11 | CHKSUM10 | CHKSUM9 | CHKSUM8 | CHKSUM7 | CHKSUM6 | CHKSUM5 | CHKSUM4 | CHKSUM3 | CHKSUM2 | CHKSUM1 | CHKSUM0 |
| ISVEC | 0 | 0 | 0 | 0 | 0 | 0 | 0 | 0 | 0 | 0 | 0 | 0 | ISVEC3 | ISVEC2 | ISVEC1 | ISVECO |
| T2CFG2 | 0 | 0 | 0 | 0 | 0 | 0 | 0 | 0 | T2C1 | T2DIV2 | T2DIV1 | T2DIV0 | T2MD | CCF1 | CCF0 | CT2 |
| STAO | 0 | 0 | 0 | 0 | 0 | 0 | 0 | 0 | — | — | — | — | — | — | INP | BUSY |
| SMD | 0 | 0 | 0 | 0 | 0 | 0 | 0 | 0 | EIR | OFS | — | — | — | IE | SMOD | FEDE |
| FCON | 0 | 0 | 0 | 0 | 0 | 0 | 0 | 0 | FTF | FRF | TXFT1 | TXFT0 | RXFET1 | RXFET0 | OE | FEN |
| CNT0 | 0 | 0 | 0 | 0 | 0 | 0 | 0 | 0 | WU | FP1 | FP0 | INE | AUT | INIT | LUN1 | LUN0 |
| CNT2 | 0 | 0 | 0 | 0 | 0 | 0 | 0 | 0 | — | — | — | DMIS | PM | HDO | FBS | BTH |
| IDFB | 0 | 0 | IDFBH5 | IDFBH4 | IDFBH3 | IDFBH2 | IDFBH1 | IDFBH0 | — | — | IDFB5 | IDFB4 | IDFB3 | IDFB2 | IDFB1 | IDFB0 |
| SADDR | 0 | 0 | 0 | 0 | 0 | 0 | 0 | 0 | SADDR7 | SADDR6 | SADDR5 | SADDR4 | SADDR3 | SADDR2 | SADDR1 | SADDR0 |
| SADEN | 0 | 0 | 0 | 0 | 0 | 0 | 0 | 0 | SADEN7 | SADEN6 | SADEN5 | SADEN4 | SADEN3 | SADEN2 | SADEN1 | SADEN0 |

16-Bit, RISC, Microcontroller-Based, Ultrasonic Distance-Measuring System

MAXQ7667

Table 4. Peripheral Register Bit Functions and Reset Values (continued)

| REGISTER | REGISTER BIT | | | | | | | | | | | | | | | |
|----------|--------------|-------------|-------------|-------------|-------------|-------------|-------------|--------------|---------------|---------------|--------------|-------------|-------------|-------------|-------------|-------------|
| | 15 | 14 | 13 | 12 | 11 | 10 | 9 | 8 | 7 | 6 | 5 | 4 | 3 | 2 | 1 | 0 |
| BT | BT15 0 | BT14 0 | BT13 0 | BT12 0 | BT11 0 | BT10 0 | BT9 0 | BT8 0 | BT7 0 | BT6 0 | BT5 0 | BT4 0 | BT3 0 | BT2 0 | BT1 0 | BT0 0 |
| TMR | TMR15 0 | TMR14 0 | TMR13 0 | TMR12 0 | TMR11 0 | TMR10 0 | TMR9 0 | TMR8 0 | TMR7 0 | TMR6 0 | TMR5 0 | TMR4 0 | TMR3 0 | TMR2 0 | TMR1 0 | TMR0 0 |
| BPH | BSTT 0 | BOS 0 | — | — | — | — | BPH9 0 | BPH8 0 | BPH7 0 | BPH6 0 | BPH5 0 | BPH4 0 | BPH3 0 | BPH2 0 | BPH1 0 | BPH0 0 |
| BTRN | BDIV3 1 | BDIV2 0 | BDIV1 0 | BDIV0 1 | BPOL 0 | BCKS 1 | BTRI 0 | BGT 0 | BCTN7 0 | BCTN6 0 | BCTN5 0 | BCTN4 0 | BCTN3 0 | BCTN2 0 | BCTN1 0 | BCTN0 0 |
| SARC | — | — | — | — | SARWX2 0 | SARWX1 0 | SARWX0 0 | SARDIF 0 | SARBIP 0 | SARDUL 0 | SARSSEL 0 | SARASD 0 | SARBY 0 | SARC2 0 | SARC1 0 | SARCO 0 |
| RCVC | — | — | — | — | — | — | — | LMAOSEL 0 | LMAISEL1 0 | LMAISEL0 0 | — | RCVGN4 0 | RCVGN3 0 | RCVGN2 0 | RCVGN1 0 | RCVGN0 0 |
| PLLF | — | — | — | — | — | PLLC1 0 | PLLC0 0 | PLLF8 0 | PLLF7 0 | PLLF6 0 | PLLF5 0 | PLLF4 0 | PLLF3 0 | PLLF2 0 | PLLF1 0 | PLLF0 0 |
| AIE | — | — | — | — | — | — | — | — | XTIE 0 | VIBIE 0 | VDBIE 0 | VABIE 0 | CMPIE 0 | LFLIE 0 | LPFIE 0 | SARIE 0 |
| CMPC | CMPP 0 | CMPH14 0 | CMPH13 0 | CMPH12 0 | CMPH11 0 | CMPH10 0 | CMPH9 0 | CMPH8 0 | CMPH7 0 | CMPH6 0 | CMPH5 0 | CMPH4 0 | CMPH3 0 | CMPH2 0 | CMPH1 0 | CMPH0 0 |
| CMPT | CMPT15 0 | CMPT14 0 | CMPT13 0 | CMPT12 0 | CMPT11 0 | CMPT10 0 | CMPT9 0 | CMPT8 0 | CMPT7 0 | CMPT6 0 | CMPT5 0 | CMPT4 0 | CMPT3 0 | CMPT2 0 | CMPT1 0 | CMPT0 0 |
| ASR | VIOLVL 0 | DVLVL 0 | AVLVL 0 | CMPLVL 0 | — | — | — | XTRDY 0 | XTI 0 | VIBI 0 | VDBI 0 | VABI 0 | CMPI 0 | LPFFL 0 | LPFRDY 0 | SARRDY 0 |
| SARD | — | — | — | — | SARD11 0 | SARD10 0 | SARD9 0 | SARD8 0 | SARD7 0 | SARD6 0 | SARD5 0 | SARD4 0 | SARD3 0 | SARD2 0 | SARD1 0 | SARD0 0 |
| LPFC | FFIL3 0 | FFIL2 0 | FFIL1 0 | FFILO 0 | FFDP3 0 | FFDP2 0 | FFDP1 0 | FFDP0 0 | FFOV 0 | — | — | — | FFLD 0 | FFLS2 0 | FFLS1 0 | FFLS0 1 |
| OSCC | — | — | — | — | — | — | — | — | — | — | — | — | SARCD1 0 | SARCD0 0 | XTE 0 | RCE 0 |
| BPFI | BPFI15 0 | BPFI14 0 | BPFI13 0 | BPFI12 0 | BPFI11 0 | BPFI10 0 | BPFI9 0 | BPFI8 0 | BPFI7 0 | BPFI6 0 | BPFI5 0 | BPFI4 0 | BPFI3 0 | BPFI2 0 | BPFI1 0 | BPFI0 0 |
| BPFO | BPFO15 0 | BPFO14 0 | BPFO13 0 | BPFO12 0 | BPFO11 0 | BPFO10 0 | BPFO9 0 | BPFO8 0 | BPFO7 0 | BPFO6 0 | BPFO5 0 | BPFO4 0 | BPFO3 0 | BPFO2 0 | BPFO1 0 | BPFO0 0 |
| LPFD | LPFD15 0 | LPFD14 0 | LPFD13 0 | LPFD12 0 | LPFD11 0 | LPFD10 0 | LPFD9 0 | LPFD8 0 | LPFD7 0 | LPFD6 0 | LPFD5 0 | LPFD4 0 | LPFD3 0 | LPFD2 0 | LPFD1 0 | LPFD0 0 |
| LPFF | LPFF15 0 | LPFF14 0 | LPFF13 0 | LPFF12 0 | LPFF11 0 | LPFF10 0 | LPFF9 0 | LPFF8 0 | LPFF7 0 | LPFF6 0 | LPFF5 0 | LPFF4 0 | LPFF3 0 | LPFF2 0 | LPFF1 0 | LPFF0 0 |
| APE | — | RBUFE 0 | RSARE 0 | BGE 0 | LRIOPD 0 | LRDPD 0 | LRAPD 0 | VIBE 0 | VDPE 1 | VDBE 0 | VABE 0 | SARE 0 | PLE 0 | MDE 0 | LNAE 0 | BIASE 0 |

NOT INITIALIZED

16-Bit, RISC, Microcontroller-Based, Ultrasonic Distance-Measuring System

Table 4. Peripheral Register Bit Functions and Reset Values (continued)

| REGISTER | 15 | 14 | 13 | 12 | 11 | 10 | 9 | 8 | REGISTER BIT | | | | | | | |
|----------|----|----|----|----|----|----|---|--------|--------------|---|---|---|---|---|---|---|
| | | | | | | | | | 7 | 6 | 5 | 4 | 3 | 2 | 1 | 0 |
| FGAIN | | | | | | | | [15:0] | 0x7B5C | | | | | | | |
| B1COEF | | | | | | | | [15:0] | 0x2492 | | | | | | | |
| B2COEF | | | | | | | | [15:0] | 0x5820 | | | | | | | |
| B3COEF | | | | | | | | [15:0] | 0x2410 | | | | | | | |
| A2A | | | | | | | | [15:0] | 0x30F4 | | | | | | | |
| A2B | | | | | | | | [15:0] | 0x3369 | | | | | | | |
| A2D | | | | | | | | [15:0] | 0x3A28 | | | | | | | |
| A3A | | | | | | | | [15:0] | 0xE20E | | | | | | | |
| A3B | | | | | | | | [15:0] | 0xE1E3 | | | | | | | |
| A3D | | | | | | | | [15:0] | 0xE5F9 | | | | | | | |

Bits indicated by "ST" reflect the input signal state.

Bits indicated by "P" are cleared to 00h on POR and then, if required, initialized to a value stored within the flash information block.

Bits indicated by "DB" have read/write access only in background or debug mode. These bits are cleared after a POR.

Bits indicated by "DW" are only written to in debug mode. These bits are cleared after a POR.

The OSCC register is cleared to 0002h after a POR and is not affected by other forms of reset.

16-Bit, RISC, Microcontroller-Based, Ultrasonic Distance-Measuring System

MAXQ7667

Applications Information

Development and Technical Support

A variety of highly versatile, affordably priced development tools for this μ C are available from Maxim and third-party suppliers, including:

- Compilers
- Evaluation kit
- Integrated development environments (IDEs)
- JTAG-to-serial converters for programming and debugging

A partial list of development tool vendors can be found at [www.maxim-ic.com/MAXQ tools](http://www.maxim-ic.com/MAXQ_tools).

Technical support is available at <https://support.maxim-ic.com/micro>.

Additional Documentation

Designers must have the following documents to fully use all the features of this device. This data sheet contains pin descriptions, feature overviews, and electrical specifications. Errata sheets contain deviations from published specifications. The user's guides offer detailed information about device features and operation. The following documents can be downloaded from www.maxim-ic.com/microcontrollers.

- This MAXQ7667 data sheet, which contains electrical/timing specifications and pin descriptions.
- The MAXQ7667 revision-specific errata sheet (www.maxim-ic.com/errata).
- The *MAXQ7667 Family User's Guide*, which contains detailed information on core features and operation, including programming.

Pin Configuration

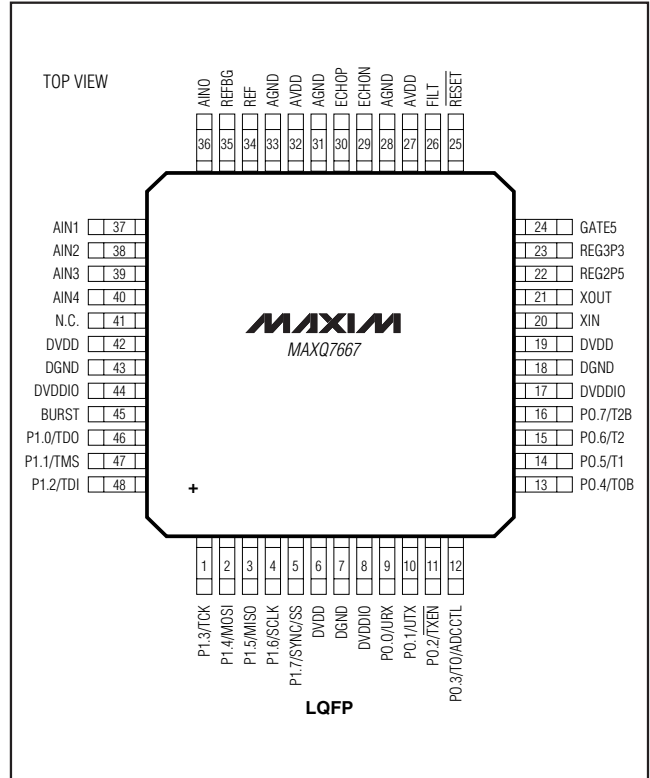

Chip Information

PROCESS: CMOS

Package Information

For the latest package outline information and land patterns, go to www.maxim-ic.com/packages.

| PACKAGE TYPE | PACKAGE CODE | DOCUMENT NO. |
|--------------|--------------|-------------------------|
| 48 LQFP | C48+2 | 21-0054 |

16-Bit, RISC, Microcontroller-Based, Ultrasonic Distance-Measuring System

Revision History

| REVISION NUMBER | REVISION DATE | DESCRIPTION | PAGES CHANGED |
|-----------------|---------------|---|---------------|
| 0 | 4/09 | Initial release | — |
| 1 | 7/09 | Updated <i>Ordering Information</i> to indicate automotive qualified part | 1 |

Maxim cannot assume responsibility for use of any circuitry other than circuitry entirely embodied in a Maxim product. No circuit patent licenses are implied. Maxim reserves the right to change the circuitry and specifications without notice at any time.

40 _____ **Maxim Integrated Products, 120 San Gabriel Drive, Sunnyvale, CA 94086 408-737-7600**