



MAX9728A Evaluation Kit

General Description

The MAX9728A evaluation kit (EV kit) is a fully assembled and tested surface-mount circuit board that evaluates the MAX9728A DirectDrive™ stereo headphone amplifier. Maxim's DirectDrive technology eliminates the need for DC-blocking capacitors on the stereo outputs of the amplifier. Designed to operate from a 2.7V to 5.5V DC power supply, the EV kit is capable of delivering up to 42mW per channel into a 16Ω load or 63mW per channel into a 32Ω load at 1% THD+N ($V_{DD} = 5V$).

The EV kit can be configured as a line driver to deliver 2V_{RMS} into a 10kΩ load from a single 3.3V DC supply. The MAX9728A EV kit also evaluates the MAX9728B IC.

Features

- ◆ No Bulky DC-Blocking Capacitors Required
- ◆ 2.7V to 5.5V DC Single-Supply Operation
- ◆ 63mW Per Channel into 32Ω ($V_{DD} = 5V$)
- ◆ Low 0.02% THD+N at 1kHz
- ◆ High 86dB PSRR Eliminates LDO
- ◆ 2V_{RMS} Audio Line Driver from a Single 3.3V Supply
- ◆ Fully Assembled and Tested Surface-Mount Board

Ordering Information

PART	TEMP RANGE	IC PACKAGE
MAX9728AEVKIT	0°C to +70°C	12 Thin QFN

Note: To evaluate the MAX9728B, request a MAX9728BETC+ free sample with the MAX9728AEVKIT.

Component List

DESIGNATION	QTY	DESCRIPTION
C1, C2, C3	3	1.0μF ±10%, 10V X7R ceramic capacitors (0603) TDK C1608X7R1A105K Taiyo Yuden LMK107BJ105KA
C4*	1	10μF ±20%, 6.3V X5R ceramic capacitor (0805) TDK C2012X5R0J106M Taiyo Yuden JMK212BJ106MG
E1, E7	2	15kΩ ±1% resistors (0603)
E2, E8	2	30.1kΩ ±1% resistors (0603)
E3, E9	2	0.47μF ±10%, 6.3V X7R ceramic capacitors (0603) TDK C1608X5R0J474K

*System-level requirement.

DESIGNATION	QTY	DESCRIPTION
E4, E10	2	0Ω resistors (0603)
E5, E6, E11, E12	0	Not installed (0603)
J1	1	Stereo headphone jack (3.5mm dia.)
JU1	1	3-pin header
U1	1	MAX9728AETC+ (12-pin TQFN, 3mm x 3mm x 0.8mm)
—	1	Shunt
—	1	MAX9728A EV kit PC board

Component Suppliers

SUPPLIER	PHONE	FAX	WEBSITE
AVX	843-946-0238	843-626-3123	www.avxcorp.com
Taiyo Yuden	800-348-2496	847-925-0899	www.t-yuden.com
TDK	847-803-6100	847-390-4405	www.component.tdk.com

Note: Indicate that you are using the MAX9728A when contacting these component suppliers.



MAX9728A Evaluation Kit

Quick Start

Recommended Equipment

- One pair of 16 Ω or 32 Ω headphones
- One DC power supply capable of supplying between 2.7V and 5.5V at 500mA
- One stereo audio source

Procedures

The MAX9728A EV kit is fully assembled and tested. Follow the steps below to verify board operation. **Do not turn on the power supply until all connections are completed:**

- 1) Verify that a shunt is installed across pins 1 and 2 of jumper JU1.
- 2) Plug the headphones into the 3.5mm headphone jack.
- 3) Ensure that the stereo audio source is turned off.
- 4) Connect the disabled audio source between IN₋ and GND.
- 5) Connect the 2.7V to 5.5V DC power supply to the VDD and GND pads.
- 6) Turn on the DC power supply.
- 7) Enable the stereo audio source.

Detailed Description

The MAX9728A EV kit evaluates the MAX9728A adjustable gain, DirectDrive stereo headphone amplifier. The MAX9728A EV kit is configured with an external gain of -2V/V and can be powered from a 2.7V to 5.5V DC single supply. The MAX9728A is designed to drive 42mW per channel into a 16 Ω load or 63mW per channel into a 32 Ω load at 1% THD+N ($V_{DD} = 5V$).

The EV kit can also be configured as an audio line driver to drive 2V_{RMS} into a 10k Ω load from a single supply. An active lowpass filter can be implemented with the MAX9728A (see the *MAX9728A as a Lineout Amplifier* section). All passive components recommended for a line driver configuration are included in the MAX9728A EV kit pack-out BOM.

The MAX9728A EV kit can be used to evaluate the MAX9728B, fixed-gain, DirectDrive stereo headphone amplifier. To evaluate the MAX9728B, request a MAX9728BETC free sample with the MAX9728AEVKIT (see the *Evaluating the MAX9728B* section for more details).

Shutdown Control

Jumper JU1 controls the shutdown pin (SHDN) of the MAX9728A IC. See Table 1 for jumper shunt positions.

Table 1. Jumper JU1 Shutdown Selection

SHUNT POSITION	DESCRIPTION
1-2	Amplifier enabled
2-3	Amplifier disabled

Layout Considerations

To optimize the audio performance of the MAX9728A, it is important to follow these layout guidelines. The MAX9728A EV kit implements two ground planes to minimize the amount of charge-pump switching noise coupled into the audio signal. The two planes are star-connected at one point (GND pad). Place capacitors C1, C2, and C3 as close to the IC as possible. Use short, wide traces to connect the power pins of the IC to the power supply.

Evaluating the MAX9728B

The MAX9728A EV kit can evaluate the MAX9728B. The MAX9728B is a -1.5V/V fixed-gain version of the MAX9728A. To evaluate the MAX9728B, replace U1 with a MAX9728BETC+ IC and replace the components as outlined in Table 2. The MAX9728B IC can only be evaluated in the headphone amplifier configuration.

Table 2. Component Values for Evaluating the MAX9728B

COMPONENT	MAX9728A	MAX9728B
E1, E7	15k Ω resistors	0 Ω resistors
E2, E8	30.1k Ω resistors	Open

MAX9728A Evaluation Kit

MAX9728A as a Line Out Amplifier (Optional Configuration)

$2V_{RMS}$ is a popular audio line level, first used in CD players, but now common in DVD and set-top box (STB) interface standards. An audio system designer cannot simply run the line out stage from a typical 5V supply; the resulting output swing would be inadequate for a $2V_{RMS}$, or $5.7V_{P-P}$, output swing. A common solution to this problem is to use operational amplifiers driven from split supplies ($\pm 5V$ typically), or to use a high-voltage supply rail (9V to 12V). This output level requirement can add extra cost and complexity to the system power supply. Maxim's DirectDrive architecture grants the ability to derive $2V_{RMS}$ from a single +5V supply, or even a single +3.3V supply, at reduced system cost and component count.

When the MAX9728A is used as a line driver to provide outputs that feed stereo equipment with a digital-to-analog converter (DAC) audio input source, it is often desirable to eliminate any high-frequency quantization noise produced by the DAC output before it reaches the load. This high-frequency noise can cause the input stages of the line-in equipment to exceed slew-rate limitations or create excessive EMI emissions on the cables between devices.

The MAX9728A EV kit can be configured as a line driver with an active lowpass filter to suppress the high-frequency quantization noise produced by the DAC output. Figure 1 demonstrates the MAX9728A configured as a 2-pole Rauch/multiple-feedback filter with a passband gain of 6dB and a -3dB (below passband) cutoff frequency of approximately 27kHz (see Figure 2 for the Gain vs. Frequency plot).

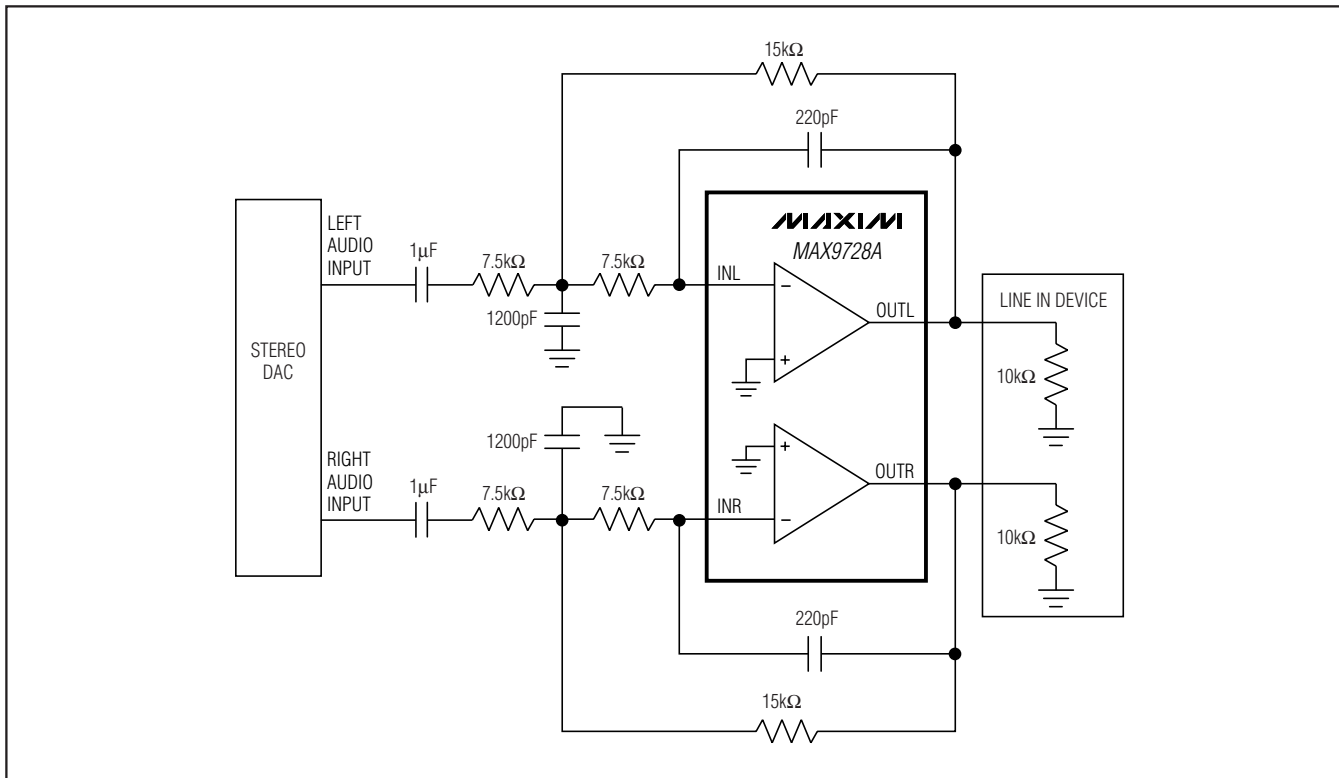

Figure 1. MAX9728A Line Out Amplifier and Filter Block Configuration

Evaluates: MAX9728A/MAX9728B

MAX9728A Evaluation Kit

To evaluate the MAX9728A EV kit in a line driver, active lowpass filter configuration, replace the passive components as outlined in Table 3. An active lowpass filter pack-out BOM is shipped with the MAX9728A EV kit. See Figure 3 for headphone amplifier configuration. See Figure 4 for line driver configuration.

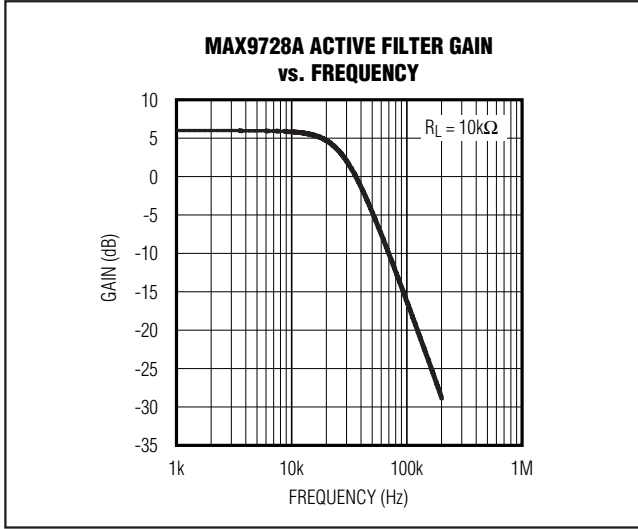

Figure 2. Gain vs. Frequency for the Line Out Amplifier ($V_{DD} = 5V$, $A_V = -2V/V$, $f = 1kHz$ to $100kHz$, $R_L = 32\Omega$)

Table 3. MAX9728A EV Kit Active Lowpass Filter Configuration

DESIGNATION	COMPONENT VALUE FOR HEADPHONE AMPLIFIER CONFIGURATION	COMPONENT VALUE FOR LINE DRIVER CONFIGURATION
E1, E7	15k Ω resistors	7.5k Ω resistors
E2, E8	30.1k Ω resistors	220pF capacitors
E3, E9	0.47 μ F capacitors	7.5k Ω resistors
E4, E10	0 Ω resistors	1 μ F capacitors
E6, E12	Open	1200pF capacitors
E5, E11	Open	15k Ω resistors

MAX9728A Evaluation Kit

Evaluates: MAX9728A/MAX9728B

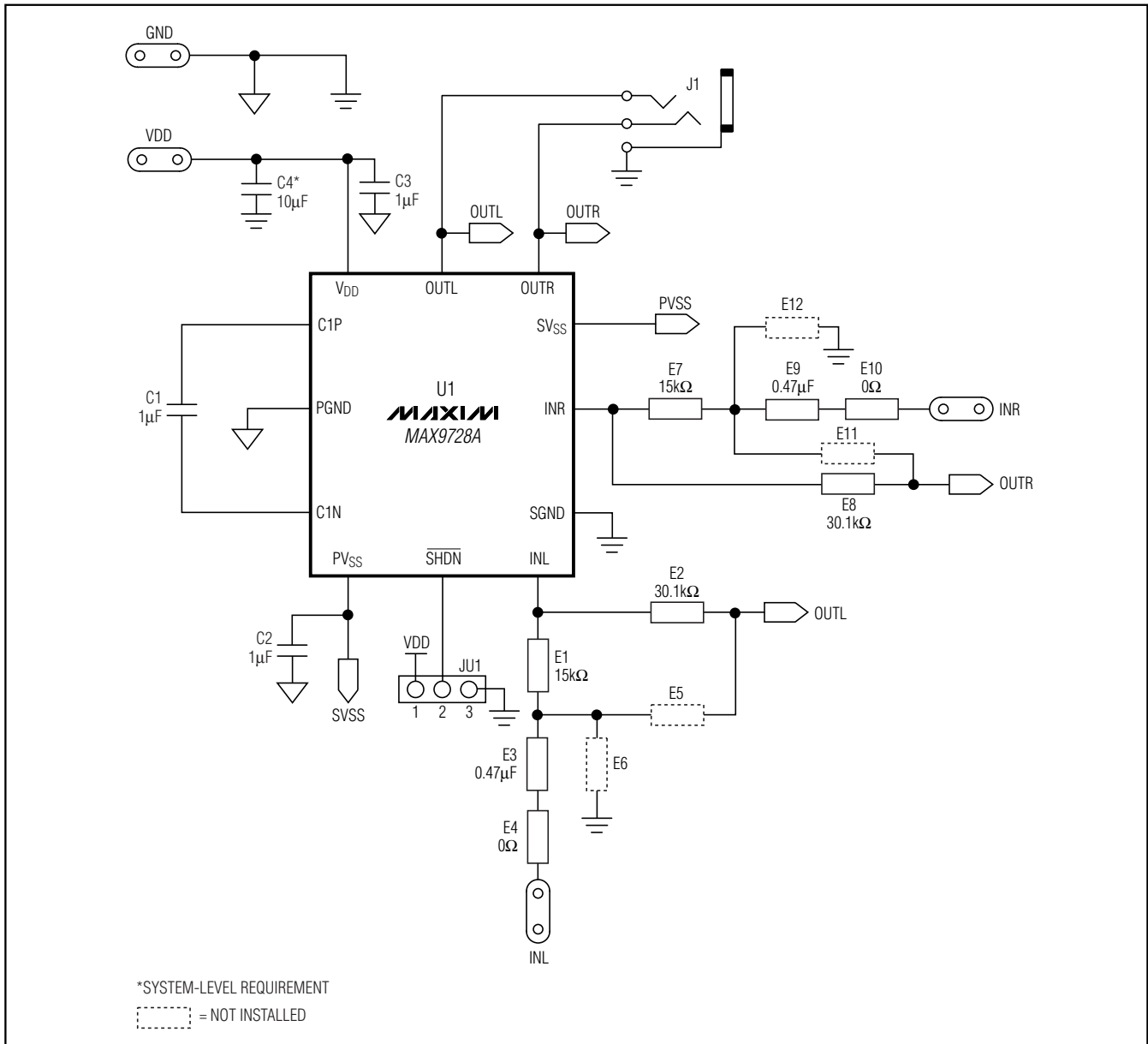

Figure 3. MAX9728A EV Kit Schematic (Headphone Amplifier Shipped Configuration)

MAX9728A Evaluation Kit

Evaluates: MAX9728A/MAX9728B

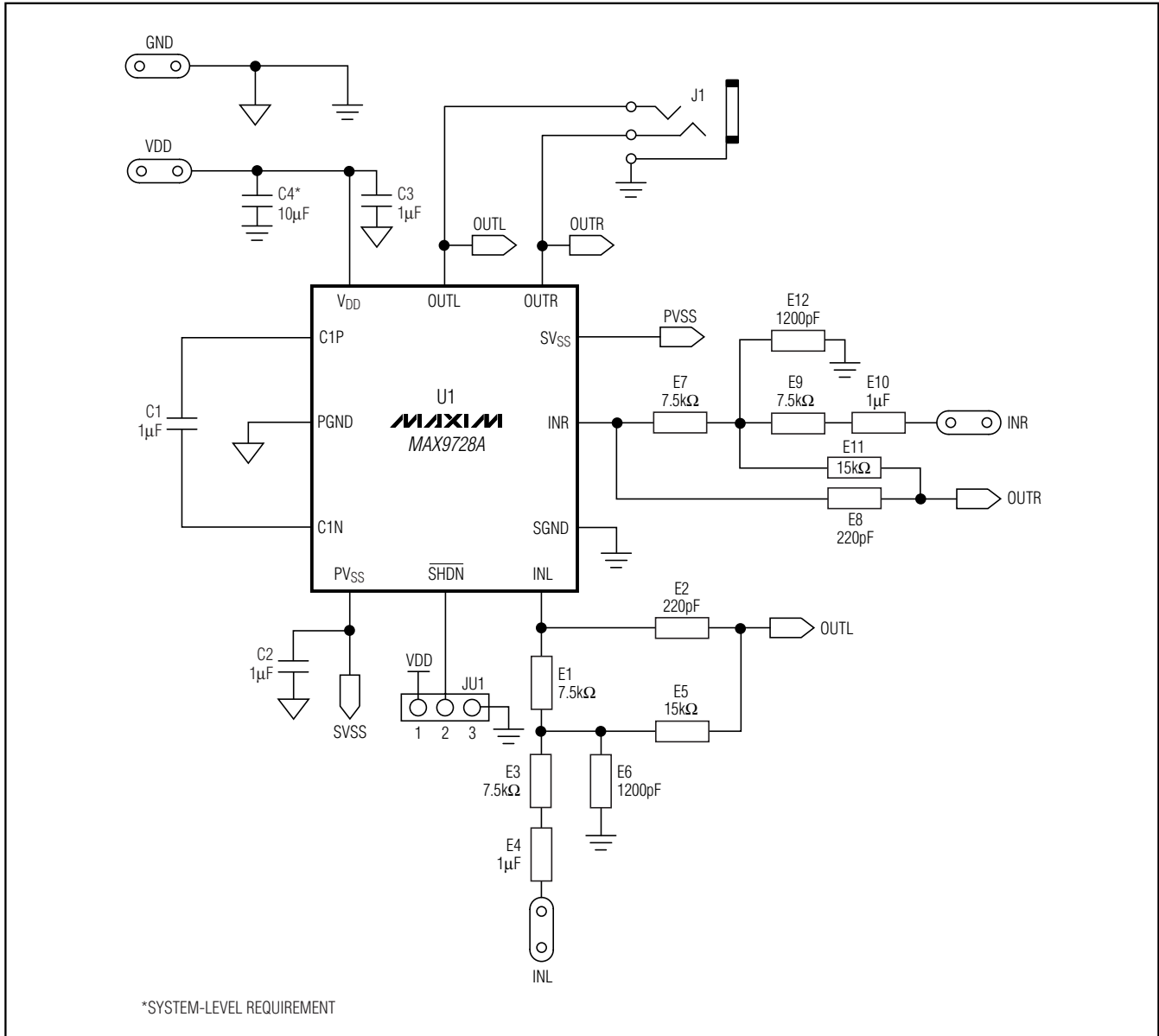

Figure 4. MAX9728A EV Kit Schematic (Optional Line Driver Configuration)

MAX9728A Evaluation Kit

Evaluates: MAX9728A/MAX9728B

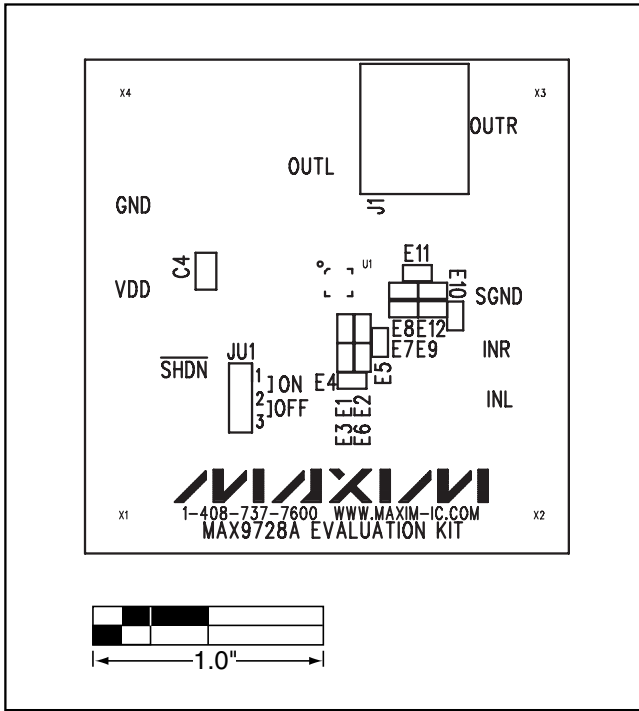

Figure 5. MAX9728A EV Kit Component Placement Guide—Component Side

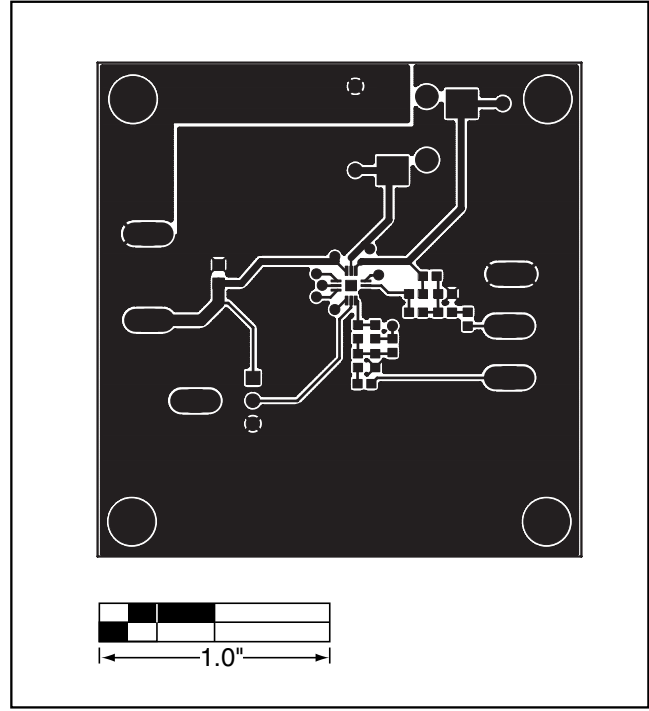

Figure 6. MAX9728A EV Kit PC Board Layout—Component Side

MAX9728A Evaluation Kit

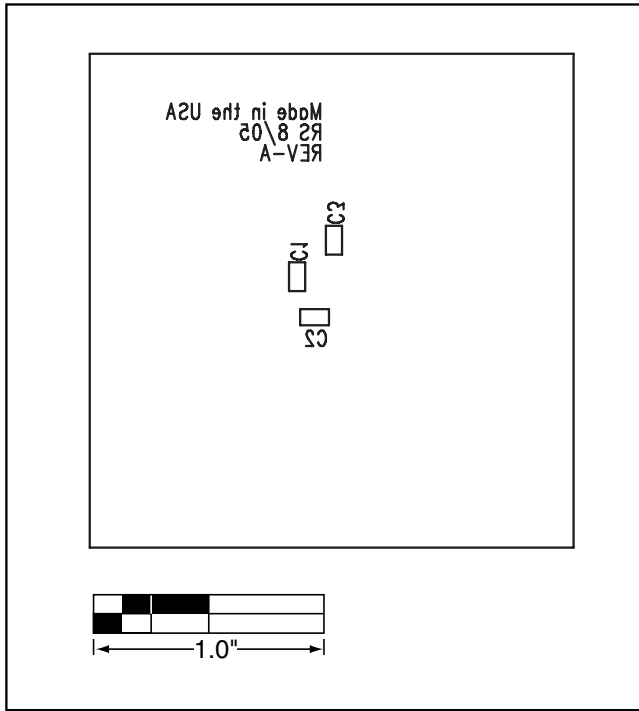

Figure 7. MAX9728A EV Kit Component Placement Guide—Solder Side

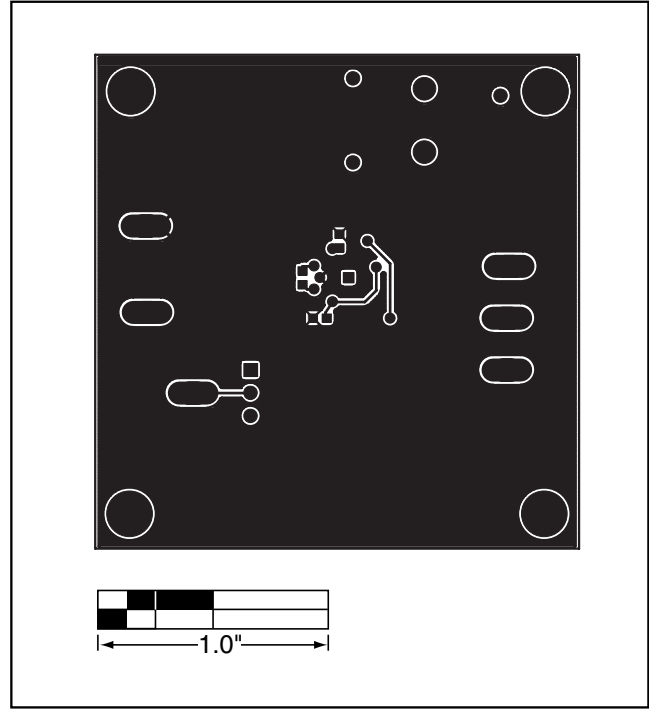

Figure 8. MAX9728A EV Kit PC Board Layout—Solder Side

Maxim cannot assume responsibility for use of any circuitry other than circuitry entirely embodied in a Maxim product. No circuit patent licenses are implied. Maxim reserves the right to change the circuitry and specifications without notice at any time.

8 _____ **Maxim Integrated Products, 120 San Gabriel Drive, Sunnyvale, CA 94086 408-737-7600**