



MAX9714 Evaluation Kit

General Description

The MAX9714 evaluation kit (EV kit) is a fully assembled and tested circuit board that contains the MAX9714 filterless class D amplifier. The EV kit is capable of delivering 6W into an 8Ω load and is designed to operate from a 10V to 25V DC power supply. The MAX9714 EV kit accepts differential or single-ended input signals and provides an option to select between different switching frequencies.

The MAX9714 EV kit can also evaluate the MAX9704 15W, filterless, class D amplifier.

Ordering Information

| PART | TEMP RANGE | IC PACKAGE |
|--------------|--------------|-------------------------|
| MAX9714EVKIT | 0°C to +70°C | 32 TQFN-EP* (7mm x 7mm) |

*EP = Exposed paddle.

Note: To evaluate the MAX9704, request a MAX9704ETJ free sample with the MAX9714EVKIT.

Features

- ◆ 10V to 25V Single-Supply Operation
- ◆ Up to 85% Efficiency
- ◆ Drives 6W into 8Ω/8W into 16Ω Speaker
- ◆ Differential or Single-Ended Input Modes
- ◆ Pin-Selectable Switching Modulation and Switching Frequency Options
- ◆ Pin-Selectable Gain Options
- ◆ Low 0.04% THD+N
- ◆ Surface-Mount Construction
- ◆ Fully Assembled and Tested

Component List

| DESIGNATION | QTY | DESCRIPTION |
|----------------------------|-----|---|
| C1 | 1 | 1000pF ±10%, 50V X7R ceramic capacitor (0603) Murata GRM188R71H102K TDK C1608X7R1H102KT |
| C2, C3 | 2 | 33μF ±10%, 35V tantalum capacitors (D case) AVX TAJD336K035 |
| C4, C5 | 2 | 0.1μF ±10%, 25V X7R ceramic capacitors (0603) Murata GRM188R71E104K TDK C1608X7R1E104K |
| C6–C9 | 4 | 100pF ±5%, 50V C0G ceramic capacitors (0402) Murata GRP155C1H101J Taiyo Yuden UMK105CG101JW |
| C10, C11, C20–C25, C28–C31 | 0 | Not installed, ceramic capacitors (0402) |
| C12–C15, C17 | 5 | 0.47μF ±10%, 6.3V X5R ceramic capacitors (0402) Murata GRM155R60J474K TDK C1005X5R0J474K |
| C16 | 1 | 0.01μF ±10%, 25V X7R ceramic capacitor (0402) Murata GRP155R71E103K TDK C1005X7R1E103K |

| DESIGNATION | QTY | DESCRIPTION |
|--------------------------------|-----|--|
| C18 | 1 | 1μF ±10%, 25V X7R ceramic capacitor (0805) TDK C2012X7R1E105K |
| C19 | 1 | 0.1μF ±10%, 25V X5R ceramic capacitor (0402) TDK C1005X5R1E104K |
| C26, C27 | 0 | Not installed, ceramic capacitors (0603) |
| D1 | 1 | 5.1V, 20mA zener diode (SOT23) Central CMPZ5231B (top mark C8F) |
| L1 | 1 | 100Ω at 1MHz, 1.7A ferrite bead (0603) Taiyo Yuden BKP1608HS101 |
| L2–L5 | 4 | 0Ω resistors (0402) |
| L6–L9 | 0 | Not installed, power inductor |
| JU1, JU2, JU8 | 3 | 2-pin headers |
| JU3–JU7 | 5 | 3-pin headers |
| R1 | 1 | 10kΩ ±5% resistor (0402) |
| R2–R5 | 0 | Not installed, resistors (0402) |
| FOUTL+, FOURL-, FOUTR+, FOUTR- | 0 | Not installed, test points |
| U1 | 1 | MAX9714EUB (32-pin thin QFN, 7mm x 7mm) |
| None | 8 | Shunts |
| None | 1 | MAX9714 PC board |

Evaluates: MAX9704/MAX9714

MAX9714 Evaluation Kit

Component Suppliers

| SUPPLIER | PHONE | FAX | WEBSITE |
|-------------|---------------|--------------|-----------------------|
| AVX | 843- 946-0238 | 843-626-3123 | www.avxcorp.com |
| Central | 631-435-1110 | 631-435-1824 | www.centrasemi.com |
| Murata | 770-436-1300 | 770-436-3030 | www.murata.com |
| Taiyo Yuden | 800-348-2496 | 847-925-0899 | www.t-yuden.com |
| TDK | 847-803-6100 | 847-390-4405 | www.component.tdk.com |

Note: Indicate that you are using the MAX9704/MAX9714 when contacting these suppliers.

Quick Start

The MAX9714 EV kit is fully assembled and tested. Follow the steps listed below to verify board operation.

Do not turn on the power supply until all connections are completed.

Recommended Equipment:

- 15V, 2A power supply
 - Audio source (i.e., CD player, cassette player)
 - 8Ω/16Ω speaker
- 1) Verify that no shunts are across jumpers JU1 and JU2 (differential input mode).
 - 2) Install shunts across pins 2 and 3 of jumper JU3 and JU8 (EV kit ON).
 - 3) Install shunts across pins 1 and 2 of jumpers JU4 and JU5 (gain = 16dB).
 - 4) Install shunts across pins 1 and 2 of jumpers JU6 and JU7 (spectrum frequency mode, 335kHz).
 - 5) Connect the speakers across the OUTL+, OUTL- and OUTR+, OUTR- pads.
 - 6) Connect the positive of the 15V power supply to the V+ pad and the ground terminal of the power supply to the GND pad.
 - 7) Connect the audio source across the VINL+, VINL- and VINR+, VINR- pads.
 - 8) Turn on the power supply, and then turn on the audio sources.

Detailed Description

The MAX9714 EV kit contains the MAX9714 filterless class D amplifier IC. The EV kit operates from a DC power supply that provides 10V to 25V and accepts a differential or single-ended audio input source. The single-ended input mode accepts a signal up to 2V_{P-P}, and the differential mode accepts a signal up to 4V_{P-P}. The audio input source is amplified to drive 6W into an 8Ω speaker.

The EV kit provides two sets of differential outputs. The main outputs OUTL+/OUTL- and OUTR+/OUTR- are filterless. However, a filter can be added for ease of evaluation with resistive loads. The filtered outputs FOUTL+/FOUTL- and FOUTR+/FOUTR- require installation of components L6–L9, C20–C31, and R2–R5. For a 16Ω load and 35kHz cutoff, see Table 1 for the suggested values. All recommended components for a 16Ω load are included in the MAX9714 EV kit. For outputs with an 8Ω load, see Table 2.

Jumper Selection

Shutdown Mode

Jumpers JU3 and JU8 control the shutdown pin (SHDN) of the MAX9714. See Table 3 for JU3 and JU8 functions.

Table 1. Recommended Filter Component for Outputs With a 16Ω Load

| COMPONENT | RECOMMENDED VALUE |
|-----------|-------------------|
| C20–C25 | 0.022μF |
| C26, C27 | 0.15μF |
| C28–C31 | 0.01μF |
| L6–L9 | 47μH |
| R2–R5 | 100Ω |

Table 2. Recommended Filter Component for Outputs With an 8Ω Load

| COMPONENT | RECOMMENDED VALUE |
|-----------|-------------------|
| C20–C25 | 0.022μF |
| C26, C27 | 0.1μF |
| C28–C31 | 0.01μF |
| L6–L9 | 22μH |
| R2–R5 | 100Ω |

MAX9714 Evaluation Kit

Evaluates: MAX9704/MAX9714

Gain Selection

Jumpers JU4 and JU5 provide an option to select the output voltage gain. See Table 4 for JU4 and JU5 functions. See Tables 7 and 8 for suggested gain and input levels.

Input Mode

Jumpers JU1 and JU2 provide an option to select between a differential or single-ended input mode of the EV kit. See Table 6 for JU1 and JU2 functions.

Switching Frequency

The MAX9714 has two operating modes, fixed-frequency modulation (FFM) mode and spread-spectrum modulation (SSM) mode. The EV kit incorporates jumpers JU6 and JU7 to control pins FS1 and FS2. See Table 5 for JU6 and JU7 functions.

Evaluating the MAX9704

To evaluate the MAX9704, remove the MAX9714 from the EV kit and replace it with MAX9704. No other components on the EV kit need to be changed.

Table 3. JU3 and JU8 Functions ($\overline{\text{SHDN}}$)

| JU3 SHUNT POSITION | JU8 SHUNT POSITION | EV KIT FUNCTION |
|--------------------|---|---|
| Pins 2 and 3 | Installed ($\overline{\text{SHDN}}$ = high) | EV kit enabled (default) |
| Pins 1 and 2 | Installed, without external signal ($\overline{\text{SHDN}}$ = low) | MAX9714 in shutdown |
| Pins 2 and 3 | Not installed, with external signal connected to $\overline{\text{SHDN}}$ pad | $\overline{\text{SHDN}}$ pin driven by external signal. Shutdown is active low. |

Table 4. JU4 and JU5 Functions (G1 and G2)

| JU4 SHUNT POSITION | JU5 SHUNT POSITION | MAX9714 GAIN (dB) | MAX9704 GAIN (dB) |
|--------------------------|--------------------------|-------------------|-------------------|
| Pins 1 and 2 (G1 = high) | Pins 1 and 2 (G2 = high) | 16 (default) | 16 |
| Pins 1 and 2 (G1 = high) | Pins 2 and 3 (G2 = low) | 13 | 13 |
| Pins 2 and 3 (G1 = low) | Pins 1 and 3 (G2 = high) | 19.1 | 19.1 |
| Pins 2 and 3 (G1 = low) | Pins 2 and 3 (G2 = low) | 22.1 | 29.6 |

Note: Make sure a shunt is installed across pins 2 and 3 of jumper JU3.

Table 5. JU6 and JU7 Functions (FS1 and FS2)

| JU6 SHUNT POSITION | JU7 SHUNT POSITION | MAX9714 SWITCHING FREQUENCY (kHz) |
|---------------------------|---------------------------|-----------------------------------|
| Pins 1 and 2 (FS1 = high) | Pins 1 and 2 (FS2 = high) | 335 \pm 8%, SSM (default) |
| Pins 1 and 2 (FS1 = high) | Pins 2 and 3 (FS2 = low) | 236, FFM |
| Pins 2 and 3 (FS1 = low) | Pins 1 and 3 (FS2 = high) | 460, FFM |
| Pins 2 and 3 (FS1 = low) | Pins 2 and 3 (FS2 = low) | 335, FFM |

Note: Make sure a shunt is installed across pins 2 and 3 of jumper JU3.

Table 6. JU1 and JU2 Functions

| SHUNT POSITION | EV KIT INPUT MODE |
|--|-----------------------------------|
| Not installed | Differential input mode (default) |
| Installed (VINL-/MINR- pad connected to GND) | Single-ended input mode |

MAX9714 Evaluation Kit

Evaluates: MAX9704/MAX9714

Table 7. MAX9714 Power vs. Gain and Input Levels

| GAIN (dB) | V _{IN} DIFF RMS (V) | R _L (Ω) | P _{OUT} AT 10% THD+N (W) |
|-----------|------------------------------|--------------------|-----------------------------------|
| 13.0 | 1.56 | 8 | 6 |
| 16.1 | 1.08 | 8 | 6 |
| 19.1 | 0.75 | 8 | 6 |
| 22.1 | 0.54 | 8 | 6 |
| 13.0 | 2.54 | 16 | 8 |
| 16.1 | 1.78 | 16 | 8 |
| 19.1 | 1.26 | 16 | 8 |
| 22.1 | 0.90 | 16 | 8 |

Table 8. MAX9704 Power vs. Gain and Input Levels

| GAIN (dB) | V _{IN} DIFF RMS (V) | R _L (Ω) | P _{OUT} AT 10% THD+N (W) |
|-----------|------------------------------|--------------------|-----------------------------------|
| 13.0 | 2.46 | 8 | 15 |
| 16.1 | 1.72 | 8 | 15 |
| 19.1 | 1.22 | 8 | 15 |
| 29.6 | 0.38 | 8 | 15 |
| 13.0 | 1.34 | 4 | 9 |
| 16.1 | 0.94 | 4 | 9 |
| 19.1 | 0.66 | 4 | 9 |
| 29.6 | 0.20 | 4 | 9 |

MAX9714 Evaluation Kit

Evaluates: MAX9704/MAX9714

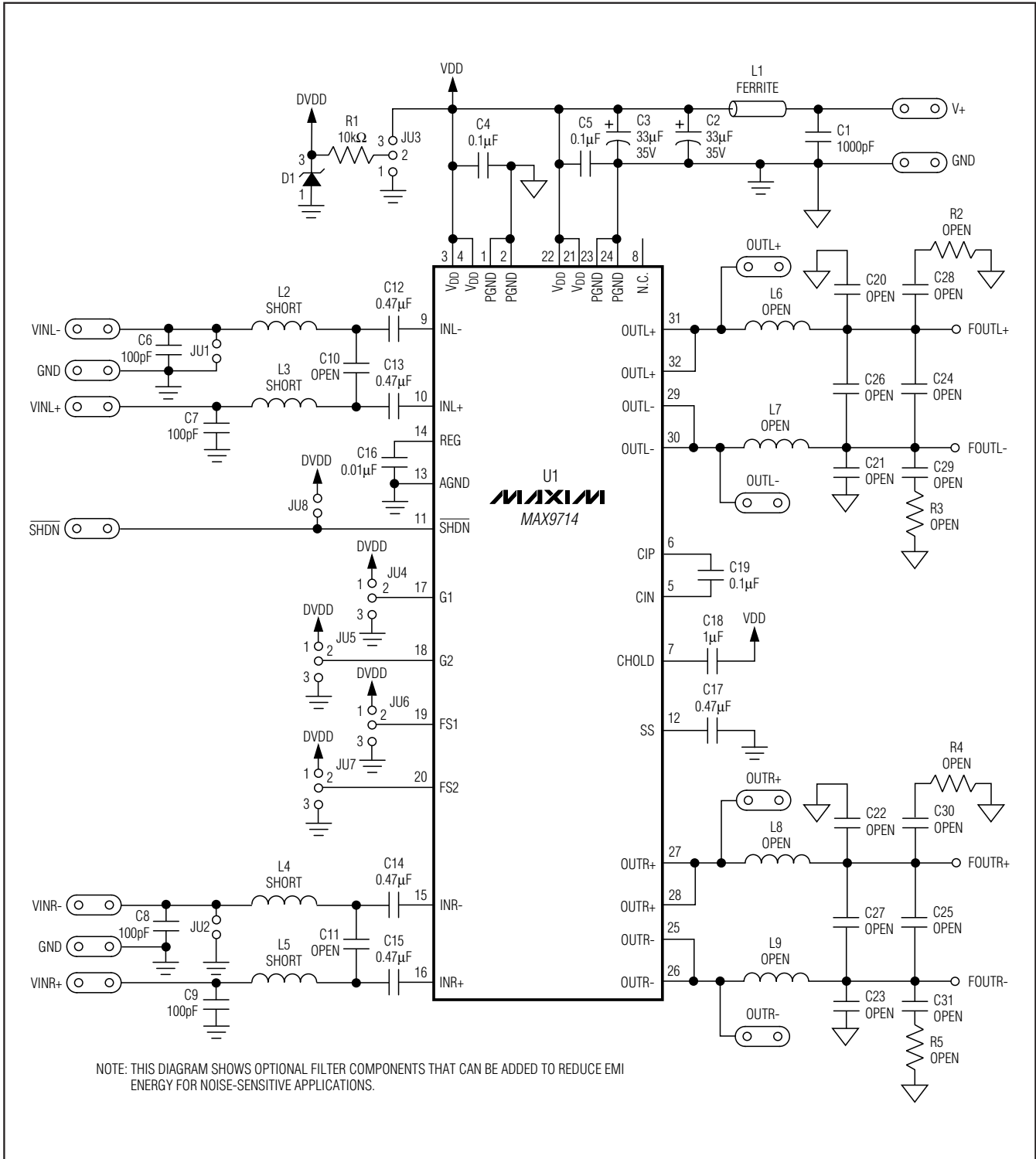

Figure 1. MAX9714 EV Kit Schematic

MAX9714 Evaluation Kit

Evaluates: MAX9704/MAX9714

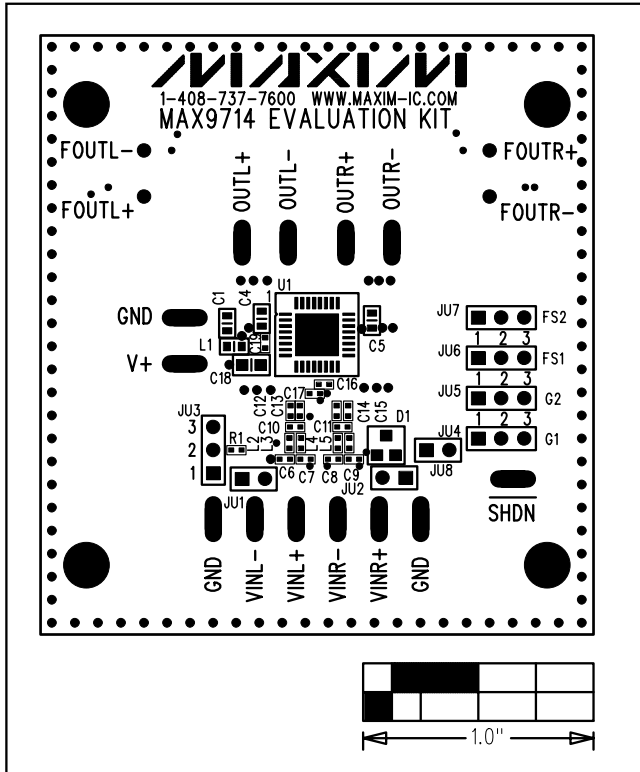

Figure 2. MAX9714 EV Kit Component Placement Guide—Component Side

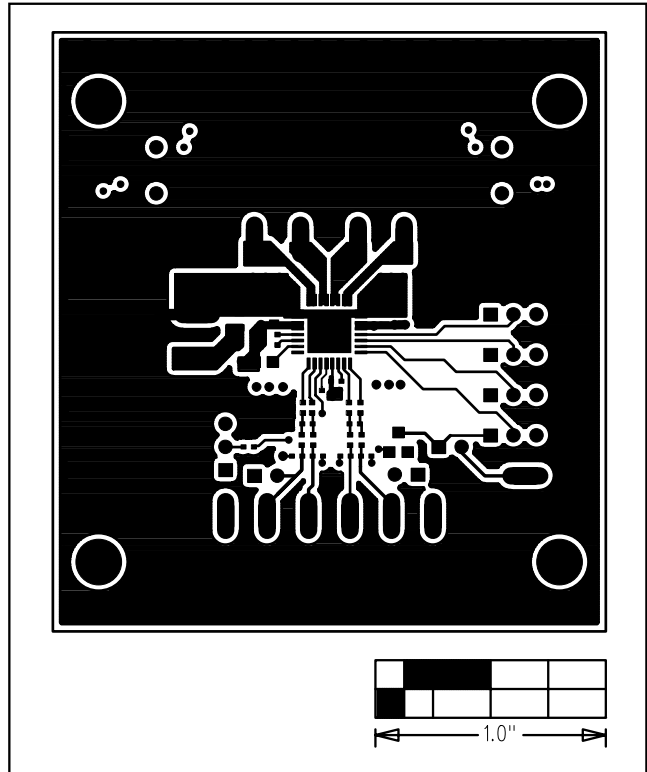

Figure 3. MAX9714 EV Kit PC Board Layout—Component Side

MAX9714 Evaluation Kit

Evaluates: MAX9704/MAX9714

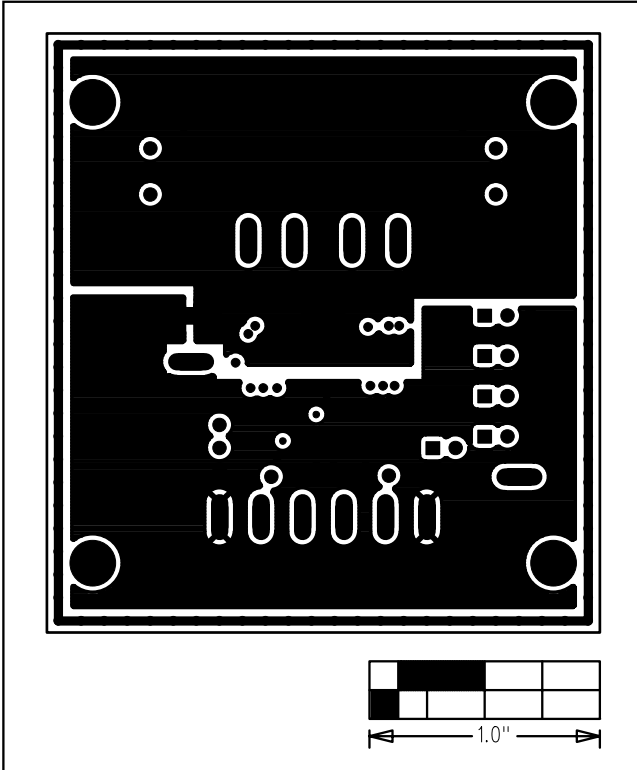

Figure 4. MAX9714 EV Kit PC Board Layout—Layer 2 (GND)

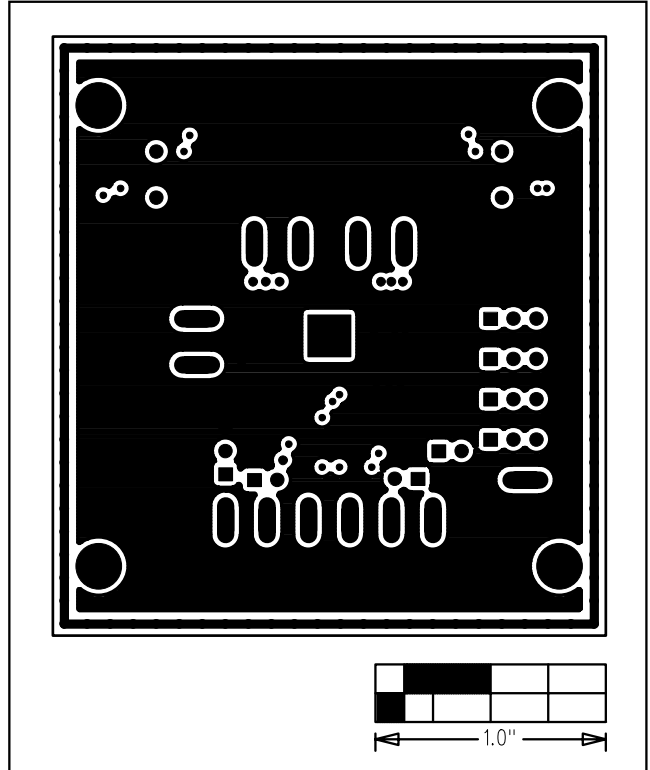

Figure 5. MAX9714 EV Kit PC Board Layout—Layer 3 (VDD)

