



MAX9485 Evaluation Kit

General Description

The MAX9485 evaluation kit (EV kit) evaluates the MAX9485, a programmable multiple-output clock generator. The EV kit provides a fixed 27MHz reference clock output, CLK0, and two buffered clock outputs, CLK1 and CLK2. The output frequency is 256, 384, or 768 times the chosen sampling frequency selected through an I²C* interface or hardwire pins. The sampling frequencies are 12kHz, 32kHz, 44.1kHz, 48kHz, 64kHz, 88.2kHz, and 96kHz. The EV kit operates from a single 3.3V power supply.

Features

- ◆ Low Single 3.3V Supply
- ◆ Controlled 50Ω Coplanar Traces
- ◆ I²C Interface or On-Board Hardwire Options for Output Clock Selection
- ◆ Fully Assembled and Tested

Ordering Information

PART	TEMP RANGE	IC PACKAGE
MAX9485EVKIT	0°C to +70°C	20 TSSOP

Component List

DESIGNATION	QTY	DESCRIPTION
C1, C2, C3	3	10μF ±20%, 6.3V X5R ceramic capacitors (0805) Taiyo Yuden JMK212BJ106MG TDK C2012X5R0J106M
C4, C5, C6, C9, C10, C11	6	0.01μF ±10%, 16V X7R ceramic capacitors (0402) Taiyo Yuden EMK105BJ103K or Murata GRM36X7R103K016
C7, C8, C17, C18, C19	0	Not installed, ceramic capacitors (0402)
C12, C13, C14	3	0.001μF ±10%, 50V X7R ceramic capacitors (0402) TDK C1005X7R1H102K
C15, C16	2	4.0pF ±0.25pF, 50V C0G ceramic capacitors (0402) TDK C1005C0G1H4R0CT

DESIGNATION	QTY	DESCRIPTION
C20	0	Not installed, ceramic capacitor (0603)
JU1–JU8	8	3-pin headers
JU9, JU10, JU11	3	2-pin headers
R1	0	Not installed, resistor (0402)
U1	1	MAX9485EUP (20-pin TSSOP)
INPUT, CLK0, CLK1, CLK2	4	SMA edge-mount connectors
Y1	1	Through-hole crystal resonator (with 14pF load capacitance) Ecliptek ECX-5527-27.000M
Y2	0	Not installed, SMD crystal resonator
—	8	Shunts
—	1	MAX9485 PC board

Component Suppliers

SUPPLIER	PHONE	FAX	WEBSITE
Ecliptek	800-433-1280	714-433-1234	www.ecliptek.com
Murata	770-436-1300	770-436-3030	www.murata.com
Taiyo Yuden	800-348-2496	847-925-0899	www.t-yuden.com
TDK	847-803-6100	847-390-4405	www.component.tdk.com

Note: Indicate that you are using the MAX9485 when contacting these component suppliers.

*Purchase of I²C components of Maxim Integrated Products, Inc., or one of its sublicensed Associated Companies, conveys a license under the Philips I²C Patent Rights to use these components in an I²C system, provided that the system conforms to the I²C Standard Specification as defined by Philips.

MAX9485 Evaluation Kit

Quick Start

The MAX9485 EV kit is fully assembled and tested. Do not turn on the power supplies until all connections are completed.

Recommended Equipment

- 3.3V, 500mA power supply
- Optional 0.0V to 3.0V, 10mA power supply (for VCXO tuning)
- Frequency counter(s)/500MHz oscilloscope

Procedure

- 1) Verify that there are no shunts across JU1 and JU2. Verify that a shunt is across on JU3 (pins 1 and 2). (Set CLK1 and CLK2 at 73.728MHz.)
- 2) Verify that there is no shunt across JU4, and there is a shunt across JU5 (pins 1 and 2). (CLK0, CLK1, and CLK2 are enabled.)
- 3) Verify that there are shunts on JU6 (pins 1 and 2) (hardwire mode), JU7 (pins 1 and 2) (internal power reset), and there is a shunt across JU8 (pins 1 and 2).
- 4) Verify that there is no shunt across JU9, JU10, and JU11.
- 5) Connect frequency counter(s) to the CLK0, CLK1, and/or CLK2 SMA connectors.
- 6) Connect the positive of the power supply to VDD, VDDP, and DVDD pads.
- 7) Connect the power ground to the GND pads.
- 8) Turn on the power supply, and enable frequency counter(s).
- 9) Verify output frequency CLK0 is around 27.000MHz, and CLK1 and CLK2 are around 73.728MHz.

Detailed Description

The MAX9485 EV kit contains the MAX9485, a programmable multiple-output clock generator. Output CLK0 provides a fixed 27MHz-reference output, and CLK1 and CLK2 provide two buffered clock outputs of 256, 384, or 768 times the chosen sampling frequency selected through an I²C interface or on-board hardwire option. Jumpers JU6, JU7, and JU8 are incorporated to control MODE, $\overline{\text{RST}}$, and TUN pins of the MAX9485 device, respectively. See Table 1 for JU6 function, Table 2 for JU7 function, and Table 3 for JU8 function.

Hardwire Mode

The EV kit provides on-board hardwire selection. Jumpers JU1–JU5 control pins SCL/FS0, SDA/FS1, FS2, SAO2, and SAO1, respectively. To set the EV kit at hardwire mode, make sure a shunt is across pins 1 and 2 of jumper JU6 (MODE = high). Jumper JU1 controls

the sampling frequency, jumper JU2 controls the frequency-scaling factors, and jumper JU3 sets the sampling rate. See Table 4 for JU1, JU2, and JU3 functions.

Jumpers JU4 and JU5 control the SAO2 and SAO1 pins of the MAX9485 device, respectively. See Table 5 for JU5 function, and Table 6 for JU4 function.

Software Mode

To use the I²C-compatible 2-wire interface, make sure a shunt is across pins 2 and 3 of jumper JU6 (MODE = low). Leave jumpers JU1, JU2, and JU3 uninstalled. Connect the external I²C clock to SCL pad and I²C data to SDA pad. At software mode, jumpers JU4 and JU5 set an 8-bit register for the device address; see Table 7 for setting the device address. Refer to the *Software Mode Programming* section on the MAX9485 IC data sheet for control register bit mapping.

Using External Clock as Reference Input

To use an external clock as reference input, remove the crystal on the board (Y1 or Y2), and install a 0 Ω resistor on R1 pads, then connect the external clock to the INPUT connector. In this case, the function of tuning output frequency is invalid.

Table 1. JU6 Function (MODE)

SHUNT LOCATION	MODE PIN	OPERATING MODE
Pins 1 and 2 (default)	Connected to DVDD	Hardwire mode
Pins 2 and 3	Connected to GND	Software mode

Table 2. JU7 Function ($\overline{\text{RST}}$)

SHUNT LOCATION	$\overline{\text{RST}}$ PIN	CHIP RESET FUNCTION
Pins 1 and 2 (default)	Connected to DVDD	On-chip internal power-on reset
Pins 2 and 3	Connected to GND	External reset

Table 3. JU8 Function (TUN)

SHUNT LOCATION	TUN PIN
Pins 1 and 2 (default)	TUN = DVDD.
Pins 2 and 3	TUN = 0.0V.
Not installed	To tune VCO frequency, apply a 0.0V to 3.0V power supply to TUN pad.

MAX9485 Evaluation Kit

Evaluates: MAX9485

Table 4. JU1, JU2, and JU3 Functions

JU1	SAMPLING FREQUENCY	JU3	SAMPLING RATE	CLK1 AND CLK2 FREQUENCY (MHz)					
	f_s (kHz)			JU2	$256 \times f_s$	JU2	$384 \times f_s$	JU2	$768 \times f_s$
Any Setting	12	Not installed	Standard	Pins 2 and 3	3.072	Pins 1 and 2	4.608	Not installed	9.126
Pins 2 and 3	32	Pins 2 and 3	Standard	Pins 2 and 3	8.1920	Pins 1 and 2	12.2880	Not installed	24.5760
Pins 1 and 2	44.1	Pins 2 and 3	Standard	Pins 2 and 3	11.2896	Pins 1 and 2	16.9344	Not installed	33.8688
Not installed	48	Pins 2 and 3	Standard	Pins 2 and 3	12.2880	Pins 1 and 2	18.4320	Not installed	36.8640
Pins 2 and 3	64	Pins 1 and 2	Double	Pins 2 and 3	16.3840	Pins 1 and 2	24.5760	Not installed	49.1520
Pins 1 and 2	88.2	Pins 1 and 2	Double	Pins 2 and 3	22.5792	Pins 1 and 2	33.8688	Not installed	67.7376
Not installed (default)	96	Pins 1 and 2 (default)	Double	Pins 2 and 3	24.5760	Pins 1 and 2	36.8640	Not installed (default)	73.7280

Table 5. JU5 Function (SAO1)

SHUNT LOCATION	SAO1 PIN	CLK0
Pins 1 and 2 (default)	Connected to DVDD	Enabled
Pins 2 and 3	Connected to GND	Disabled
Not installed	Open	Reserved

Table 6. JU4 Function (SAO2)

SHUNT LOCATION	SAO2 PIN	CLK1	CLK2
Pins 1 and 2	Connected to DVDD	Disabled	Enabled
Pins 2 and 3	Connected to GND	Enabled	Disabled
Not installed	Floating	Enabled	Enabled

Table 7. Setting Device Address

JU5	SAO1 PIN	JU4	SAO2 PIN	DEVICE ADDRESS
Not installed	Open	Not installed	Open	110 0000
Pins 2 and 3	Connected to GND	Not installed	Open	110 0011
Pins 1 and 2	Connected to DVDD	Not installed	Open	110 0010
Not installed	Open	Pins 2 and 3	Connected to GND	110 0100
Pins 2 and 3	Connected to GND	Pins 2 and 3	Connected to GND	110 1000
Pins 1 and 2	Connected to DVDD	Pins 2 and 3	Connected to GND	111 0000
Not installed	Open	Pins 1 and 2	Connected to DVDD	111 0001
Pins 2 and 3	Connected to GND	Pins 1 and 2	Connected to DVDD	111 0010
Pins 1 and 2	Connected to DVDD	Pins 1 and 2	Connected to DVDD	111 0100

MAX9485 Evaluation Kit

Evaluates: MAX9485

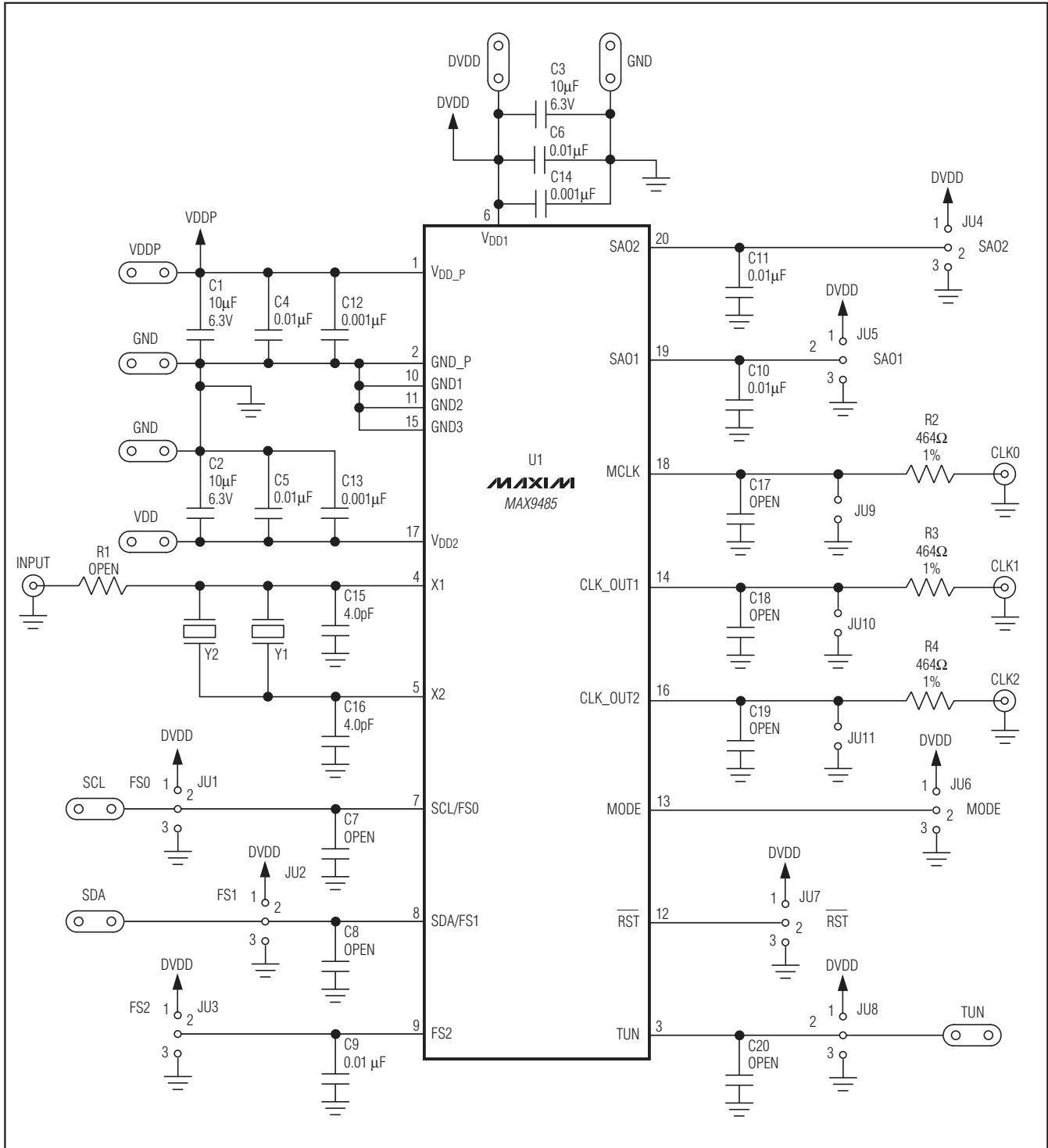

Figure 1. MAX9485 EV Kit Schematic

MAX9485 Evaluation Kit

Evaluates: MAX9485

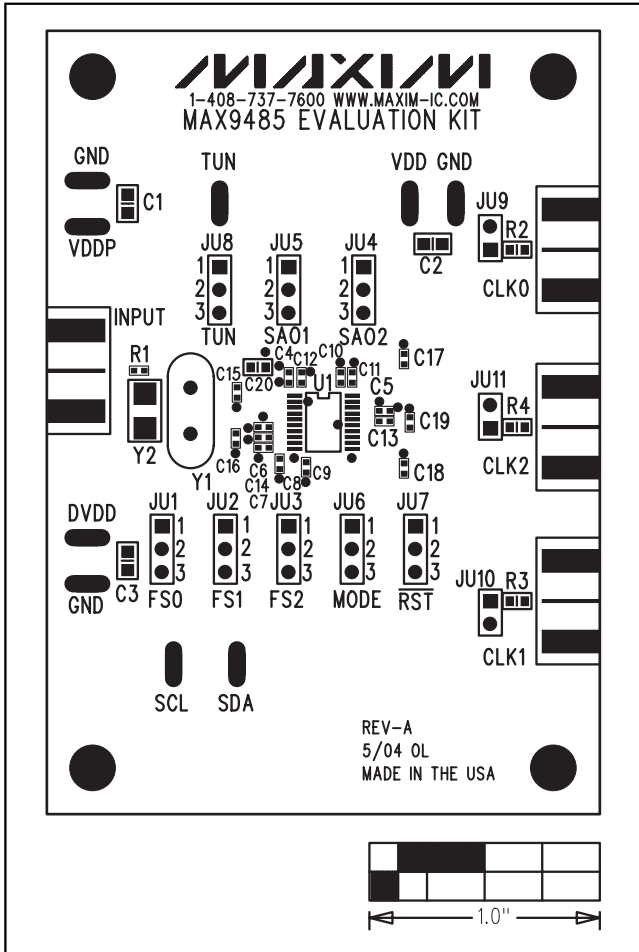

Figure 2. MAX9485 EV Kit Component Placement Guide—Component Side

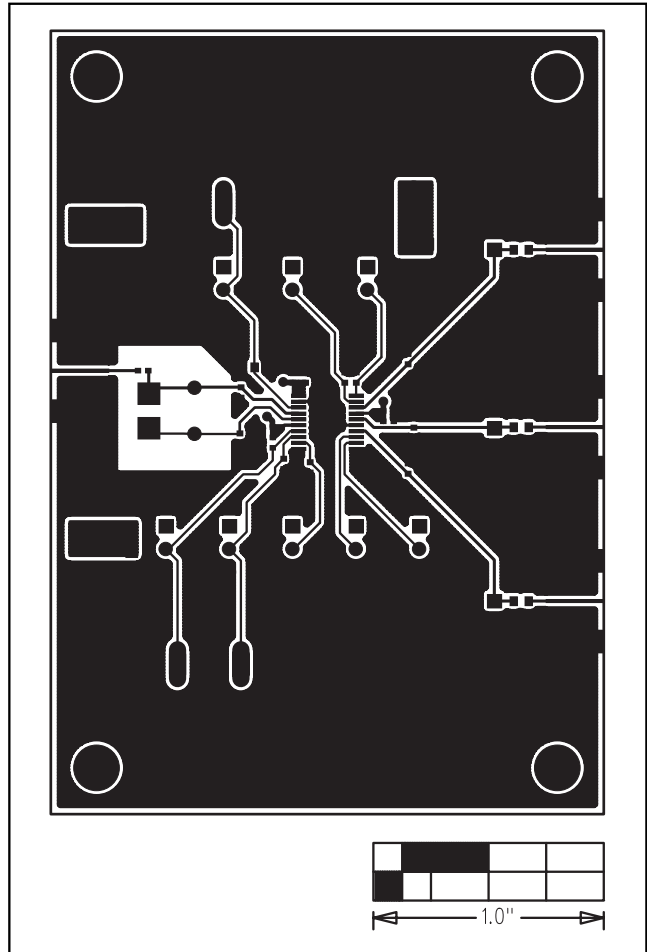

Figure 3. MAX9485 EV Kit PC Board Layout—Component Side

MAX9485 Evaluation Kit

Evaluates: MAX9485

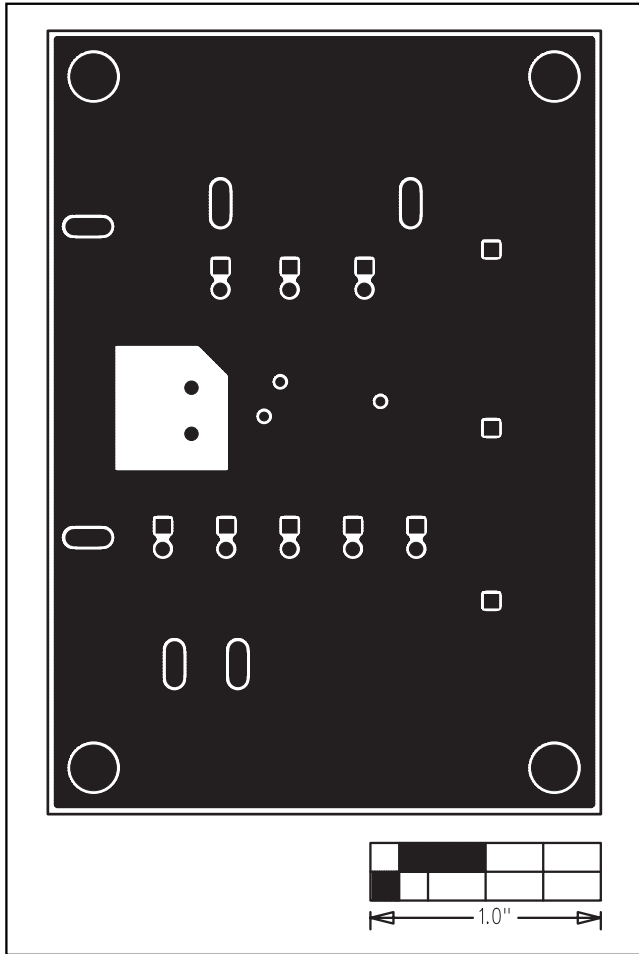

Figure 4. MAX9485 EV Kit PC Board Layout—Inner Layer 2 (GND Layer)

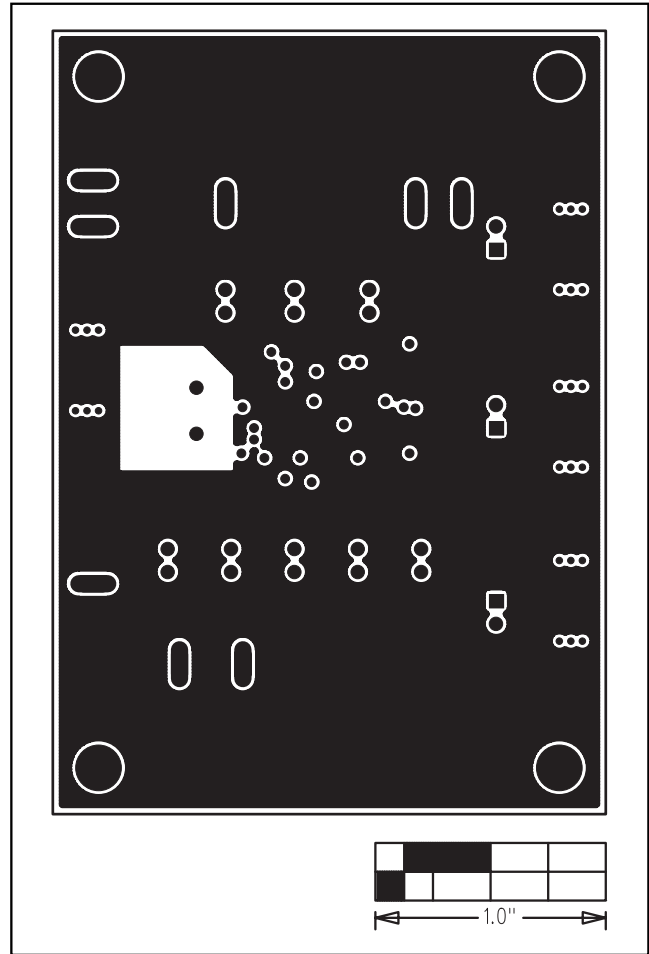

Figure 5. MAX9485 EV Kit PC Board Layout—Inner Layer 3 (DVDD Layer)

MAX9485 Evaluation Kit

Evaluates: MAX9485

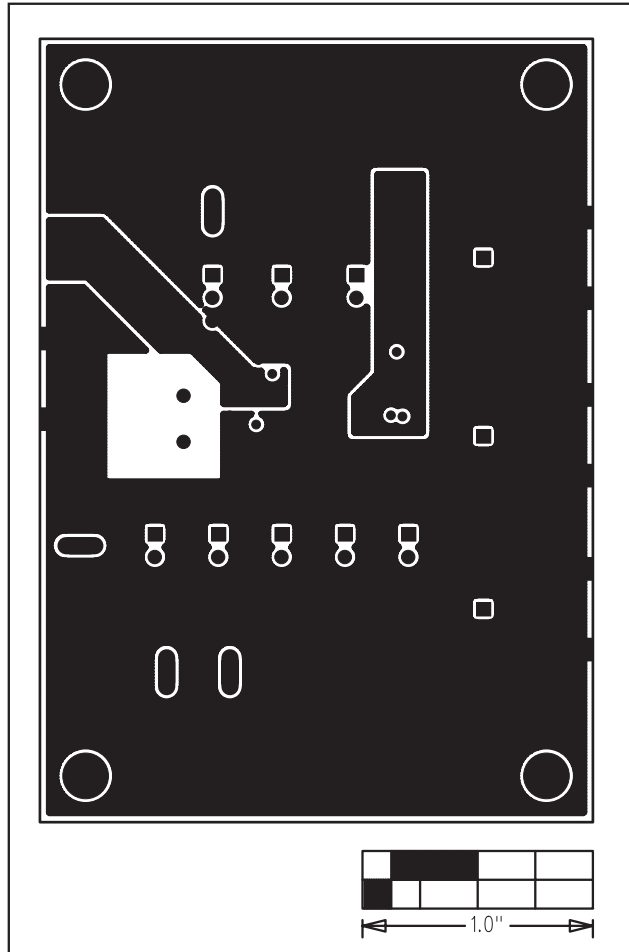

Figure 6. MAX9485 EV Kit PC Board Layout—Solder Side

Maxim cannot assume responsibility for use of any circuitry other than circuitry entirely embodied in a Maxim product. No circuit patent licenses are implied. Maxim reserves the right to change the circuitry and specifications without notice at any time.

Maxim Integrated Products, 120 San Gabriel Drive, Sunnyvale, CA 94086 408-737-7600 _____ 7