



# MAX9450 Evaluation Kit

## General Description

The MAX9450 evaluation kit (EV kit) is a fully assembled and tested PCB that demonstrates the performance of the MAX9450 high-precision clock generator for timing in SONET/SDH systems or Gigabit Ethernet systems.

The EV kit is installed with a 155.52MHz crystal. For evaluating other frequencies, remove and replace the Y1 crystal with a target crystal.

The MAX9450 EV kit includes Windows® 98SE/2000/XP-compatible software that provides a simple graphical user interface (GUI) for exercising the features of the MAX9450.

The EV kit comes with the MAX9450EHJ installed. Contact the factory for free samples of the pin-compatible MAX9451EHJ or MAX9452EHJ to evaluate these devices.

## Features

- ◆ Both I<sup>2</sup>C and SPI™ Interfaces Provided to Control the MAX9450
- ◆ Proven PCB Layout
- ◆ Windows 98SE/2000/XP-Compatible Evaluation Software
- ◆ Convenient Configuration Jumpers and Test Points
- ◆ USB-PC Connection

## Ordering Information

PART	TYPE	INTERFACE
MAX9450EVKIT	EV kit	USB

Windows is a registered trademark of Microsoft Corp.

SPI is a trademark of Motorola, Inc.

## Component List

DESIGNATION	QTY	DESCRIPTION
C1–C4, C30, C31	6	10µF ±10%, 10V X5R ceramic capacitors (0805) Murata GRM21BR61A106K or TDK C2012X5R1A106K or equivalent
C5, C6, C11–C16, C19, C20, C22–C29, C37	19	0.1µF ±10%, 16V X7R ceramic capacitors (0603) TDK C1608X7R1C104K
C7, C8	0	Not installed, ceramic capacitors (0603)
C9	1	0.01µF ±10%, 16V X7R ceramic capacitor (0603) Murata GRM188R71C103K
C10, C17, C18, C21	0	Not installed, ceramic capacitors (0603)
C32, C33	2	22pF ±5%, 50V C0G ceramic capacitors (0603) TDK C1608C0G1H220J or Murata GRM1885C1H220J or equivalent
C34	1	0.033µF ±10%, 25V X7R ceramic capacitor (0603) TDK C1608X7R1E333K or equivalent

DESIGNATION	QTY	DESCRIPTION
C35, C36	2	10pF ±5%, 50V C0G ceramic capacitors (0603) Murata GRM1885C1H100J or TDK C1608C0G1H100J or equivalent
D1	1	Red LED (0603) Lite-On LTST-C190CKT
D2	1	Green LED (0603) Lite-On LTST-C190GKT
FB1	1	Ferrite bead TDK MPZ1608S101A
INT, $\overline{\text{LOCK}}$ , SDA, SCL	4	Test points (red) Keystone Electronics 5000 or equivalent
J1–J8	8	SMA connectors, edge mount Johnson 142-0701-851
J9	1	USB type B, right-angle PC mount receptacle
J10	0	Not installed, vertical header, 2 x 5 pins
JU1–JU10	10	3-pin headers
JU11–JU14	4	2-pin headers



# MAX9450 Evaluation Kit

## Component List (continued)

DESIGNATION	QTY	DESCRIPTION
R1	1	200kΩ single-turn potentiometer
R2	1	10kΩ ±1% resistor (0603)
R3, R9, R12, R23	4	24Ω ±5% resistors (0603)
R4, R10, R13, R24, R25, R26	6	27Ω ±5% resistors (0603)
R5, R7, R15, R20, R31, R32	6	130Ω ±5% resistors (0603)
R6, R8, R16, R21	4	220Ω ±5% resistors (0603)
R11, R14, R17, R22	4	51Ω ±5% resistors (0603)
R18, R19	2	4.7kΩ ±5% resistors (0603)
R27	1	470Ω ±5% resistor (0603)
R28	1	1.5kΩ ±5% resistor (0603)
R29	1	2.2kΩ ±5% resistor (0603)
R30	1	10kΩ ±5% resistor (0603)
R33	1	100kΩ ±5% resistor (0603)
R34, R35	2	100Ω ±5% resistors (0603)
U1	1	MAX9450EHJ (32 TQFP-EP, EP grounded) high-precision clock generator
U2	1	MAXQ2000-RAX+ (68 QFN) microcontroller

DESIGNATION	QTY	DESCRIPTION
U3	1	MAX8511EXK25+ (5L SC70) LDO regulator
U4	1	USB-UART converter FTDI FT232BL
U5	1	93C46 type 3-wire EEPROM Atmel AT93C46A-10SU-2.7
Y1	1	155.520MHz crystal, fundamental mode, loading capacitance 8pF, motional capacitance > 6pF KDS America DSX321S-155.52M-8pF-30-30
Y2	0	Not installed, high-stability fundamental crystal
Y3	1	6MHz crystal Citizen HCM49-6.000MABJ-UT
Y4	1	16MHz crystal Citizen HCM49-16.000MABJ-UT
—	12	Shunts
—	1	MAX9450EVKIT PCB

## MAX9450 EV Kit Files

FILE	DESCRIPTION
INSTALL.EXE	Installs the EV kit files on your computer
MAX9450.EXE	Application program
FTD2XX.INF	USB device driver file
UNINST.INI	Uninstalls the EV kit software
TROUBLESHOOTING_USB.PDF	USB driver installation help file

## Quick Start

### Recommended Equipment

- One 3.3VDC power supply
- One 8kHz to 500MHz function generator that can generate 19.44MHz (±20PPM) square wave
- One two-channel 200MHz oscilloscope
- One digital voltmeter (DVM)
- One USB cable
- A user-supplied Windows 98SE/2000/XP PC with a spare USB port

**Note:** In the following sections, software-related items are identified by bolding. Text in **bold** refers to items directly from the EV kit software. Text in **bold and underlined** refers to items from the Windows 98SE/2000/XP operating system.

## Component Suppliers

SUPPLIER	PHONE	WEBSITE
Murata Mfg. Co., Ltd.	770-436-1300	www.murata.com
TDK Corp.	847-803-6100	www.component.tdk.com

**Note:** Indicate that you are using the MAX9450 when contacting these component suppliers.

# MAX9450 Evaluation Kit

## Procedure

The MAX9450 EV kit is fully assembled and tested. Follow the steps below to verify board operation.

**Caution: Do not turn on the power supply until all connections are completed.**

- 1) Visit the Maxim website ([www.maxim-ic.com/evkit-software](http://www.maxim-ic.com/evkit-software)) to download the most recent version of the EV kit software, 9450Rxx.ZIP.
- 2) Install the MAX9450 EV kit software on your computer by running the INSTALL.EXE program. The program files are copied and icons are created in the Windows **Start** menu.
- 3) Verify that all jumpers are in default positions, as described in Table 1.
- 4) Connect the function-generator output to SMA connector IN0+, then connect jumper JU13. Adjust the signal swing from 0 to 3.3V, square-wave frequency to 19.44MHz, and duty cycle to 50%. Use scope to verify.
- 5) Leave SMA connector IN1+ unconnected and connect jumper JU14.
- 6) Connect SMA connector CLK0+ to the oscilloscope channel-1 input.
- 7) Connect SMA connector CLK1+ to the oscilloscope channel-2 input.
- 8) Connect the USB cable from the PC to the MAX9450 EV kit board.
- 9) Unless installed previously, a **Building Driver Database** window pops up in addition to a **New Hardware Found** message. If you do not see a window similar to the one described above after 30 seconds and the device is not functional, remove the USB cable from the MAX9450 EV kit board and reconnect it. Administrator privileges are required to install the USB device driver on Windows 2000/XP.

Refer to the TROUBLESHOOTING\_USB.PDF document included with the software if you have trouble during this step.

- 10) Follow the directions of the **Add New Hardware Wizard** to install the USB device driver. Choose the **Search for the Best Driver for your Device** option. Specify the location of the device driver as **C:\Program Files\MAX9450** (default installation directory) using the **Browse** button.
- 11) Connect the 3.3VDC power supply on the MAX9450 EV kit VDD and GND pads.
- 12) Connect the 3.3VDC power supply on the MAX9450 EV kit VDDQ, VLO1, VLO2, and GND pads.
- 13) Turn on the 3.3VDC power supply. Enable the output of the function generator.
- 14) Start the MAX9450 EV kit software by opening its icon in the **Start** menu. A small window appears, as shown in Figure 1.
- 15) The **I2C** button allows you to evaluate the MAX9450 in I2C control mode. The **SPI** button allows you to evaluate the MAX9450 in SPI control mode. Click the **I2C** button. A small notification window appears, as shown in Figure 2.
- 16) Follow the instructions on the window and click **OK**. The main software window appears, as shown in Figure 3.
- 17) Verify that the status bar reads **MAX9450 EVKIT found** and **I2C Address is 0xD0**.
- 18) In the **M Divider (1-32768)** text field, type in 8 and click the **Set** button.
- 19) Verify that the waveforms on oscilloscope channel-1 and channel-2 are 155.52MHz.
- 20) Use the DVM to verify that test point  $\overline{\text{LOCK}}$  on the EV kit board is in a logic-low state.

Evaluates: MAX9450/MAX9451/MAX9452

# MAX9450 Evaluation Kit

Table 1. MAX9450 EV Kit Jumper Settings

JUMPER	SHUNT POSITION	DESCRIPTION
JU1	1-2*	Input clock IN0 activated (when CR5[3:2] = 00)
	2-3	Input clock IN0 disabled (when CR5[3:2] = 00)
JU2	1-2*	Input clock IN1 activated (when CR5[3:2] = 00)
	2-3	Input clock IN1 disabled (when CR5[3:2] = 00)
JU3	1-2*	Normal operation
	2-3	Master reset
JU4	1-2*	I <sup>2</sup> C control mode. Connect MAX9450 pin 11 to ground.
	2-3	SPI control mode. Connect MAX9450 pin 11 to interface $\overline{CS}$ signal.
JU5	1-2*	I <sup>2</sup> C control mode. Connect MAX9450 pin 12 to interface SCL signal.
	2-3	SPI control mode. Connect MAX9450 pin 12 to interface SCLK signal.
JU6	1-2*	I <sup>2</sup> C control mode. Connect MAX9450 pin 13 to interface SDA signal.
	2-3	SPI control mode. Connect MAX9450 pin 13 to interface MOSI signal.
JU7, JU8	2-3*	I <sup>2</sup> C slave address is 0xD0
	Other	See Table 2 for AD0 and AD1 configurations
JU9	2-3*	Enable input clock monitor
	1-2	Disable input clock monitor
JU10	2-3*	Enable clock output
	1-2	Disable clock output
JU11	Open	JU11 pins 1-2 for testing purpose only
JU12	Open	JU12 pins 1-2 for testing purpose only
JU13	Open	Input clock IN0 uses differential signaling
	1-2*	Input clock IN0 uses single-ended signaling
JU14	Open	Input clock IN1 uses differential signaling
	1-2*	Input clock IN1 uses single-ended signaling

\*Default position.

# MAX9450 Evaluation Kit

Evaluates: MAX9450/MAX9451/MAX9452

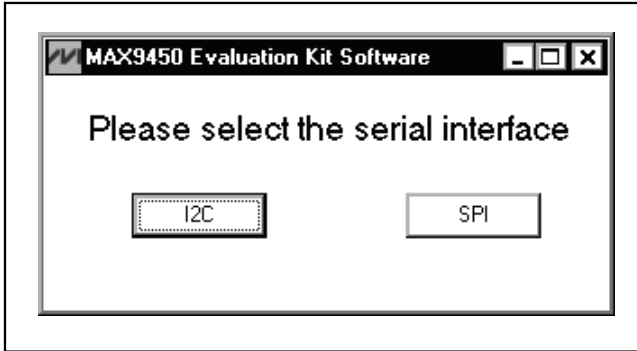

Figure 1. MAX9450 EV Kit Software—Interface Selection Window

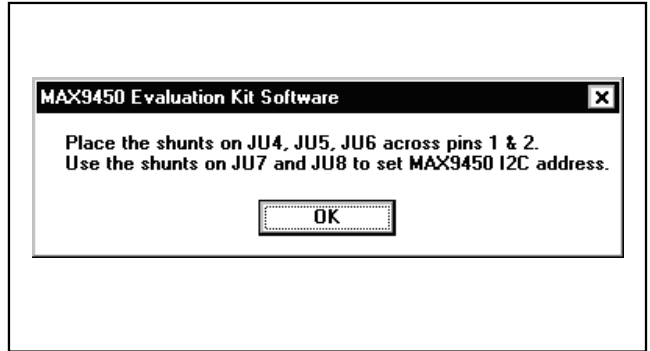

Figure 2. MAX9450 EV Kit Software—I2C Interface Notification Window

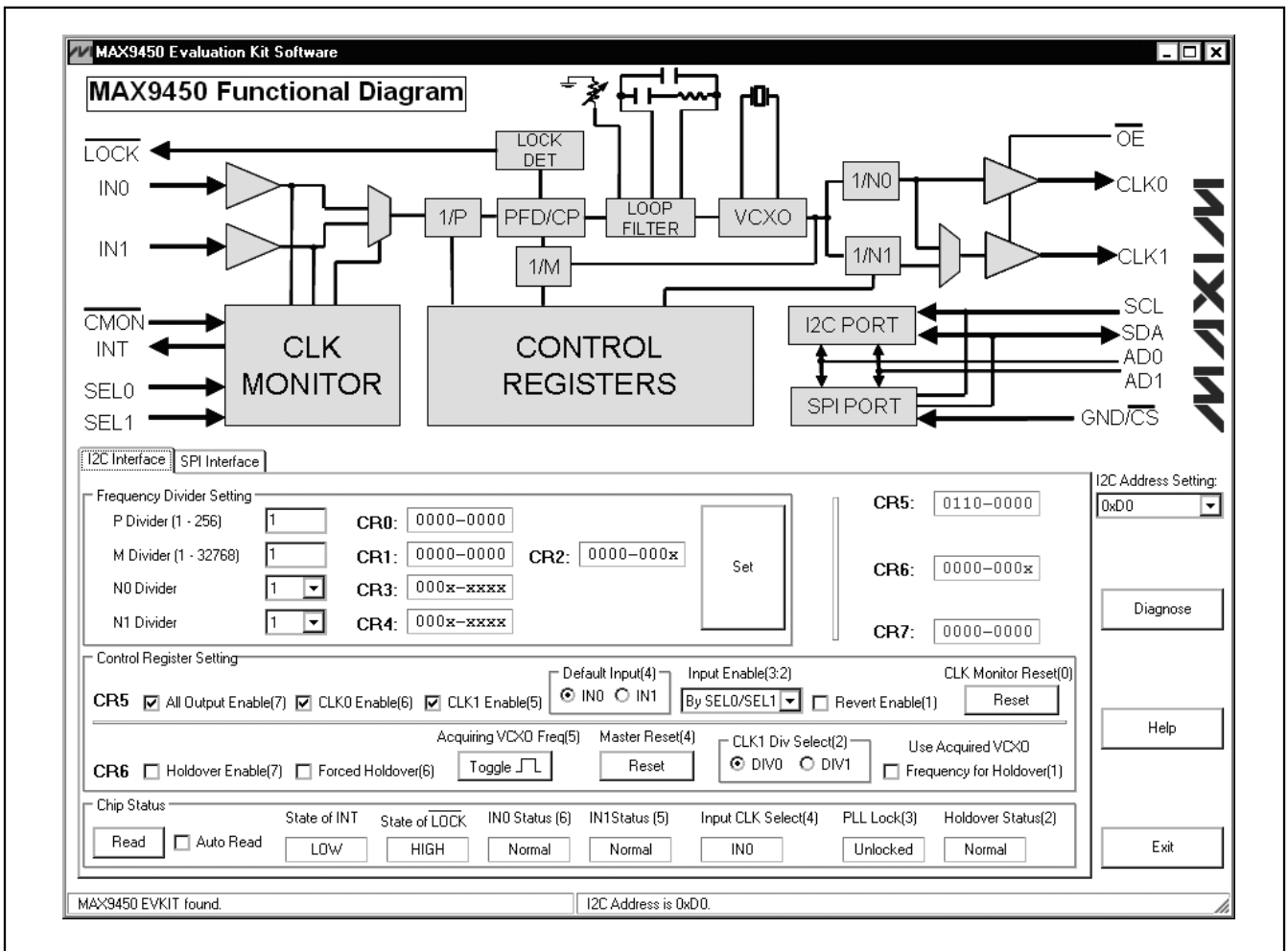

Figure 3. MAX9450 EV Kit Software—I2C Interface Tab

# MAX9450 Evaluation Kit

## Detailed Description of Software

### I2C Interface Tab

On the **I2C Interface** tab, a user sets the divider registers (i.e., M, P, N0, and N1). The output frequency at CLK<sub>n</sub> (n = 0, 1) is determined by the reference clock, and dividing factors M, Ni (i = 0, 1), and P, as shown in the following equation:

$$f_{CLKn} = f_{REF} \times \frac{M}{N_i \times P}$$

Control registers CR5 and CR6 are set in the **Control Register Setting** box.

Chip status CR7 can be monitored by clicking the **Read** button in the **Chip Status** box. Checking the **Auto Read** checkbox makes the software read the chip status approximately every one second.

### SPI Interface Tab

The **SPI Interface** tab (Figure 4) has the same function as the **I2C Interface** tab. A user can set the divider registers (i.e., M, P, N0, and N1) and control registers CR5 and CR6 as well, but chip status CR7 is not accessible in SPI control mode.

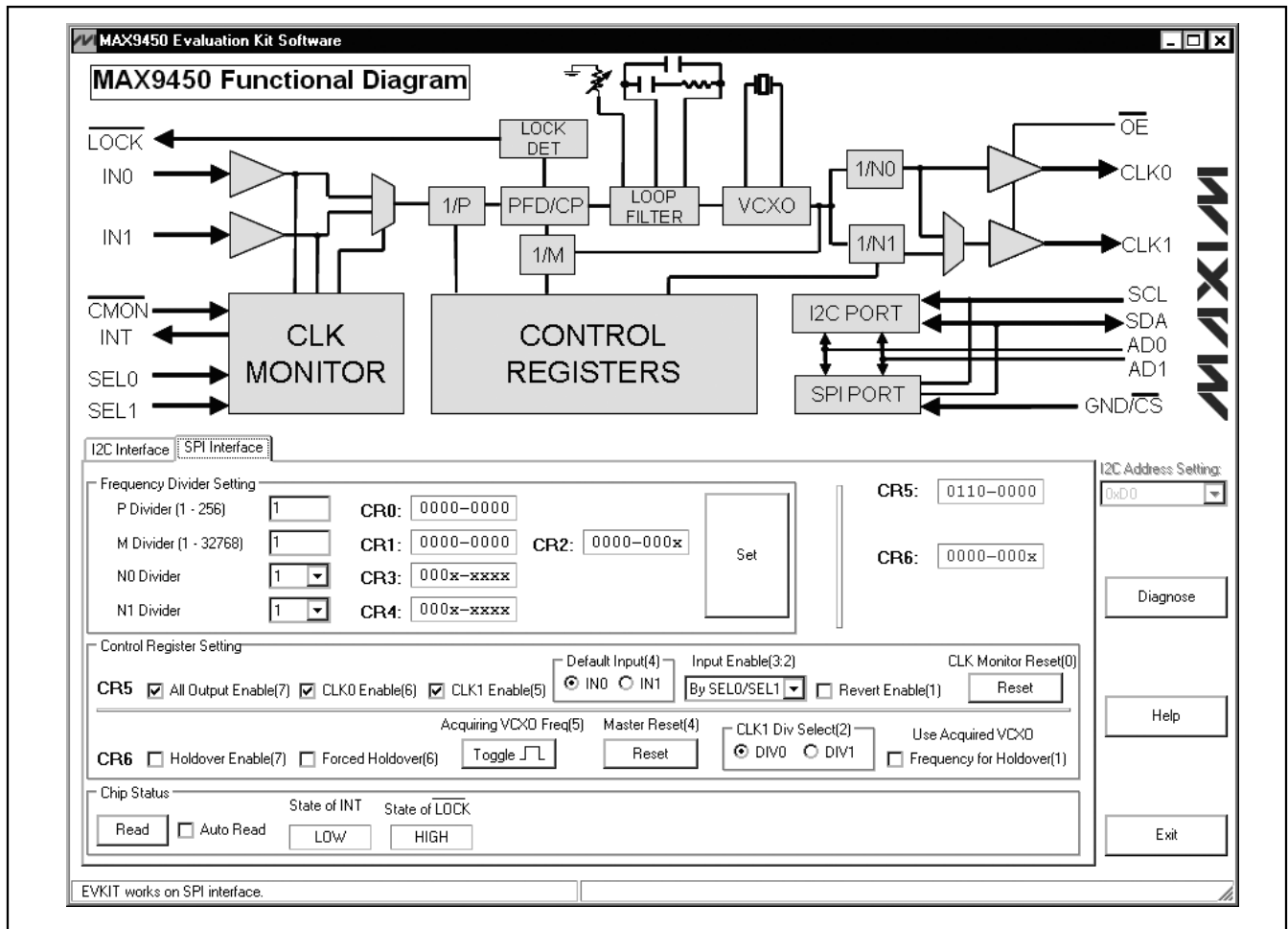

Figure 4. MAX9450 EV Kit Software—SPI Interface Tab

# MAX9450 Evaluation Kit

Evaluates: MAX9450/MAX9451/MAX9452

## I<sup>2</sup>C Address Setting

The MAX9450 I<sup>2</sup>C slave addresses are hardware-programmable by configuring jumpers JU7 and JU8, as shown in Table 2. This configuration provides eight selectable addresses for the MAX9450, allowing eight devices to be connected to one master.

Once jumpers JU7 and JU8 are changed, the user should change the **I<sup>2</sup>C Address Setting** dropdown menu on the right side of the software window to match the correct address.

**Table 2. I<sup>2</sup>C Address Setting by AD0 and AD1**

JU7 (AD0)	JU8 (AD1)	ADDRESS
2-3 (Low)	2-3 (Low)	1101 000x
2-3 (Low)	Open	1101 001x
2-3 (Low)	1-2 (High)	1101 010x
Open	2-3 (Low)	1101 011x
Open	Open	1101 100x
Open	1-2 (High)	1101 101x
1-2 (High)	2-3 (Low)	1101 110x
1-2 (High)	Open	1101 111x
1-2 (High)	1-2 (High)	Convert to SPI

## Manually Sending I<sup>2</sup>C or SPI Commands

In addition to the controls on the main window, the MAX9450 software allows the I<sup>2</sup>C or SPI commands to be entered manually. To bring up the **Maxim Command Module Interface** window (see Figure 5), click the **Diagnose** button. Enter the device address (0xD0–0xDE) under **Target Device Address**, or click the **Hunt for active listeners** button to automatically find the I<sup>2</sup>C address. Under the **General Commands** tab, select **1 - SMBusWriteByte(addr,cmd,data8)**. Under **Command byte**, enter the register address, and under **Data Out**, enter the data byte to write to the register. Note that the byte can be entered in hexadecimal prefixed with “0x” or in binary with no prefix.

Similar operations can be done in SPI control mode using the **3-wire interface** tab.

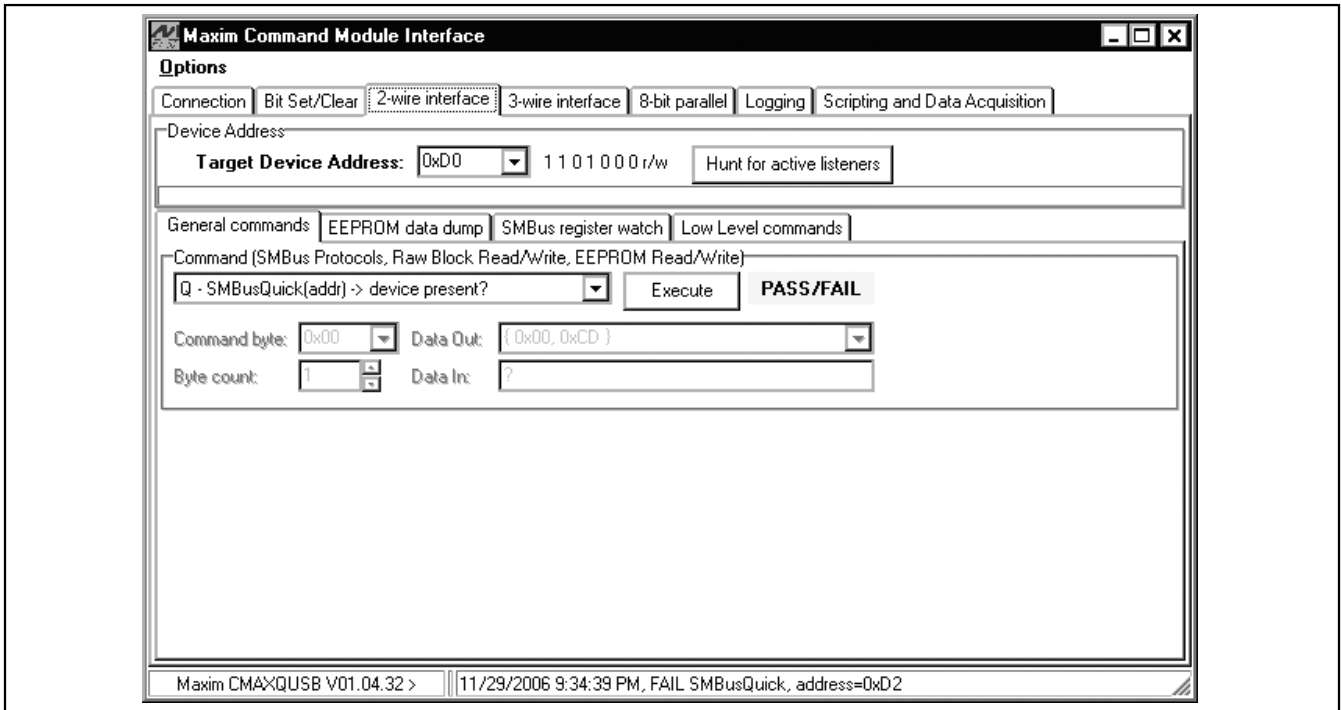

Figure 5. MAX9450 EV Kit Software—Maxim Command Module Interface Window

# MAX9450 Evaluation Kit

## Detailed Description of Hardware

The MAX9450 (U1) is a high-precision clock generator. The digital power supply is VDD; the clock output power supply is VDDQ. Both operate from 2.4V to 3.6V. The device registers are controlled through an I<sup>2</sup>C or SPI interface.

On the left portion of the EV kit PCB, I<sup>2</sup>C and SPI interfaces are provided. The MAXQ2000 microcontroller (U2) generates both I<sup>2</sup>C and SPI control signals. A PC communicates with the microcontroller through a USB-UART converter.

SMA connectors are provided for the clock input and output connections. If clock input signals are differential, leave JU13 or JU14 open. If clock input signals are single-ended, connect the input clock signal to IN0+ or IN1+, and place a shunt on JU13 or JU14.

### **Evaluating the MAX9451/MAX9452**

The MAX9450 EV kit supports the MAX9451 with HSTL output and the MAX9452 with LVDS output. Request a free sample from Maxim and change the component values as shown in Table 3 for proper output signaling.

**Table 3. Output Bias Network Component Values for Evaluating MAX9451/MAX9452**

COMPONENT	MAX9451 (HSTL OUTPUT) ( $\Omega$ )	MAX9452 (LVDS OUTPUT) ( $\Omega$ )
R3, R9, R12, R23	0	24
R4, R10, R13, R24	0	22.4
R5, R7, R15, R20	Open	137.5
R6, R8, R16, R21	Open	220

### **Evaluating Other Frequencies**

The EV kit is installed with a 155.52MHz crystal. For evaluating other frequencies, remove and replace the Y1 crystal with a target crystal.

For details, refer to Maxim application note 3920, *Component Selection and Performance Test for the MAX945x High-Precision CLK Generators*, located at [www.maxim-ic.com/appnotes.cfm/an\\_pk/3920](http://www.maxim-ic.com/appnotes.cfm/an_pk/3920).

### **Clock Monitor Functions**

To test the features of the clock monitor, apply the same frequency at the input IN0+ to the input IN1+ and connect jumper JU14. To avoid using two clock generators, use a T connector to split the input clock in two for IN0+ and IN1+. In such a case, you may need to increase the clock signal swing to compensate the increase on the load. Reset the clock monitor by connecting the shunt on jumper JU9 in the 1-2 position and then back to the 2-3 position. Once the clock monitor is reset, it is ready to test the monitor functions, such as the clock-condition monitoring, input swapping, revert function, and holdover function. Clicking the **Read** button in the programming window provides status of the chip. After INT goes high, resetting the clock monitor as described above also resets INT.

# MAX9450 Evaluation Kit

Evaluates: MAX9450/MAX9451/MAX9452

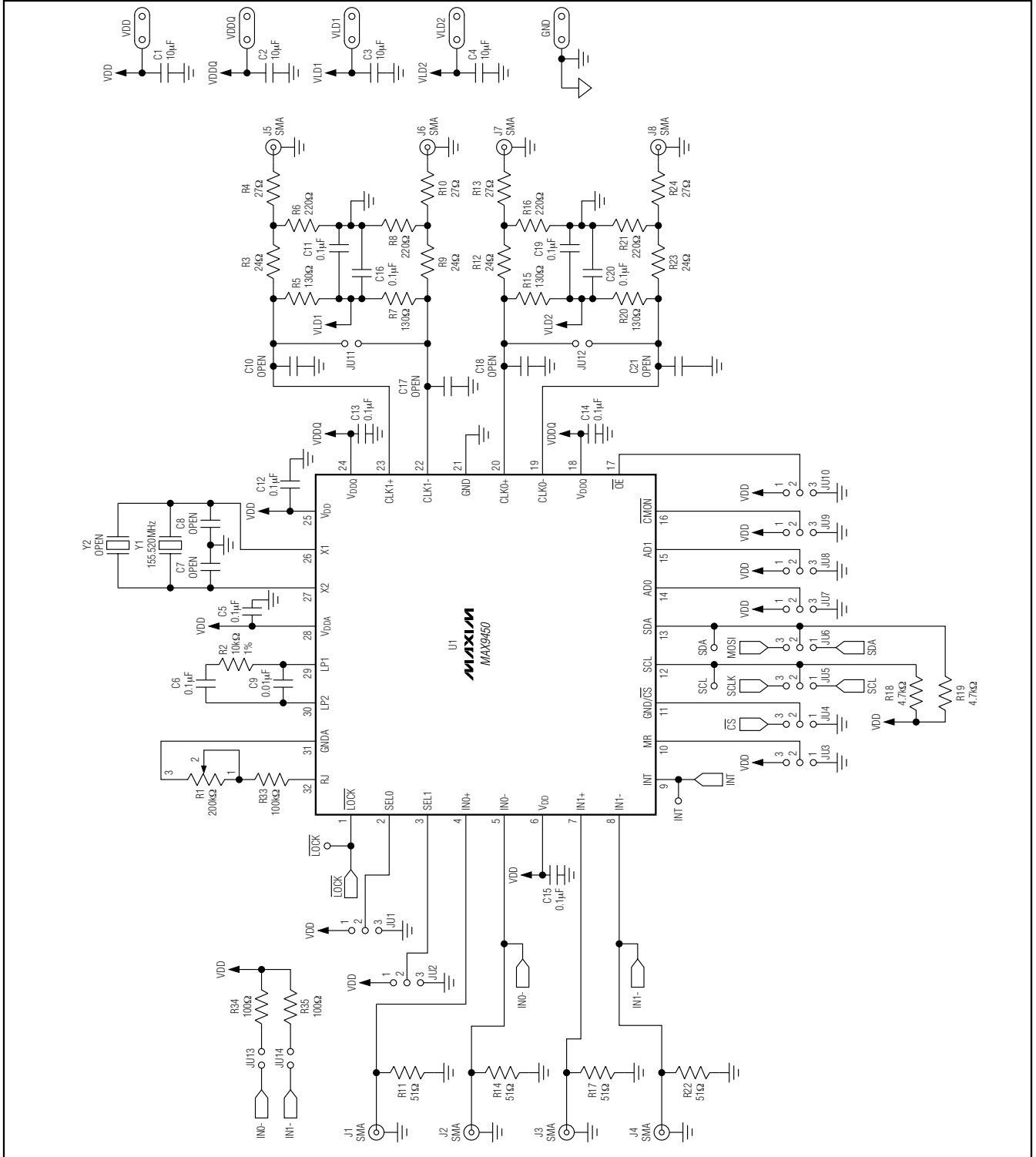

Figure 6a. MAX9450 EV Kit Schematic (Sheet 1 of 2)



# MAX9450 Evaluation Kit

Evaluates: MAX9450/MAX9451/MAX9452

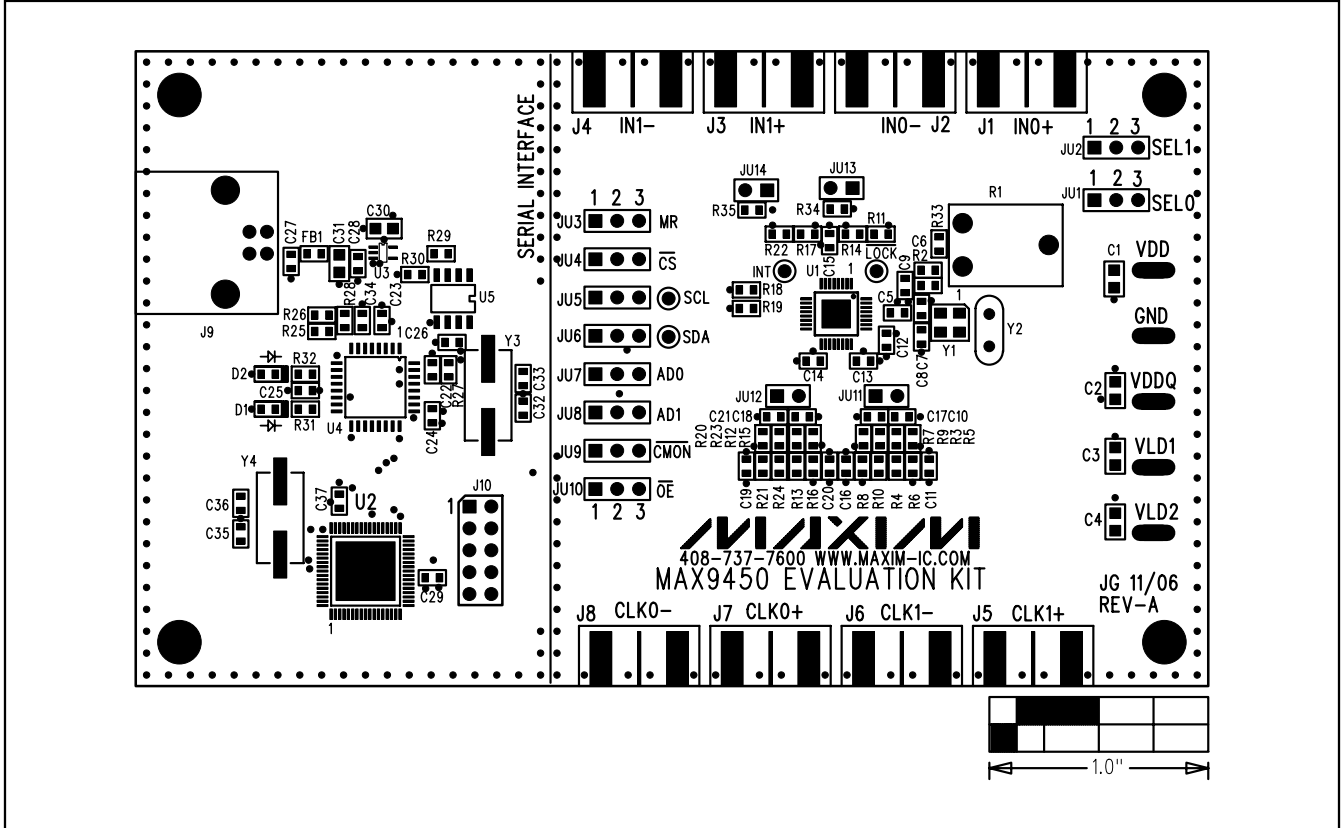

Figure 7. MAX9450 EV Kit Component Placement Guide—Component Side

# MAX9450 Evaluation Kit

Evaluates: MAX9450/MAX9451/MAX9452

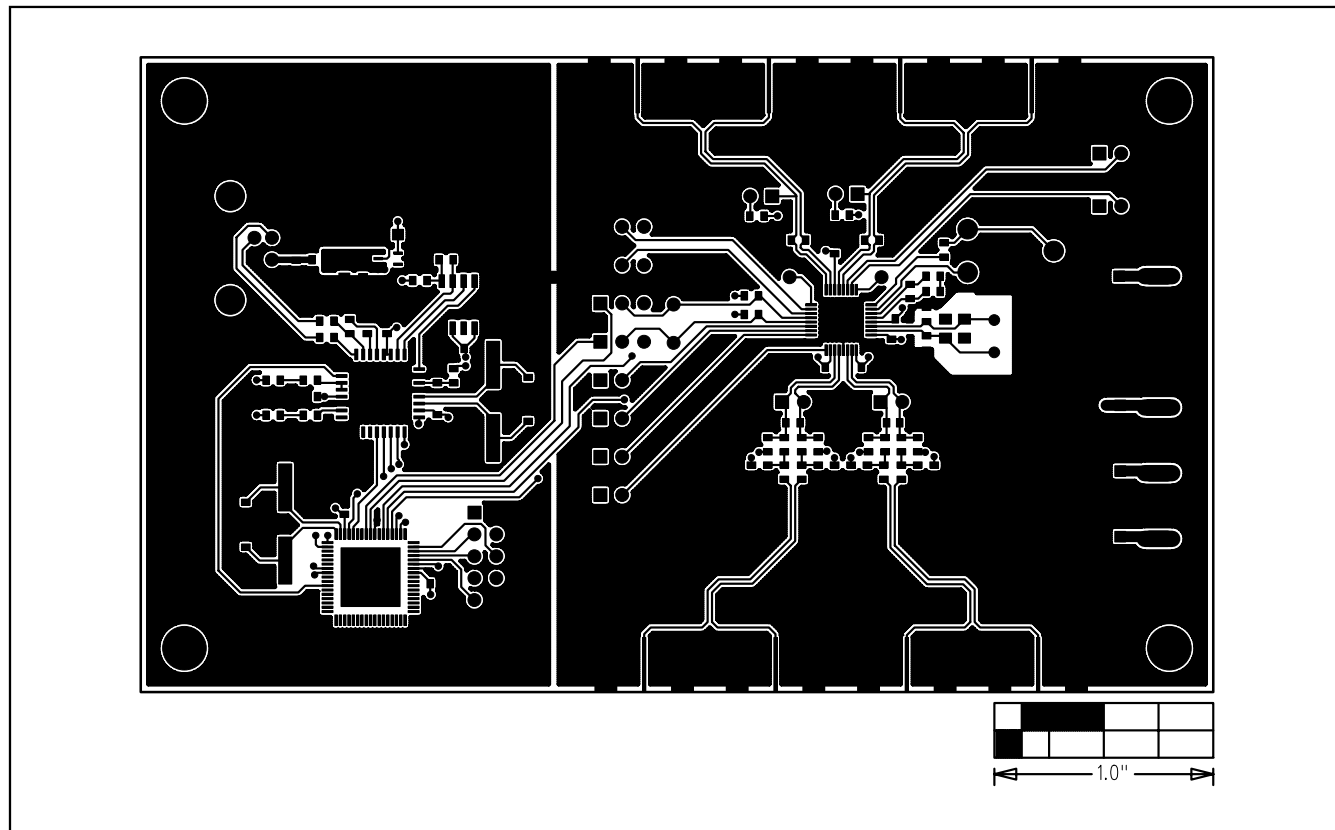

Figure 8. MAX9450 EV Kit PCB Layout—Component Side

# MAX9450 Evaluation Kit

Evaluates: MAX9450/MAX9451/MAX9452

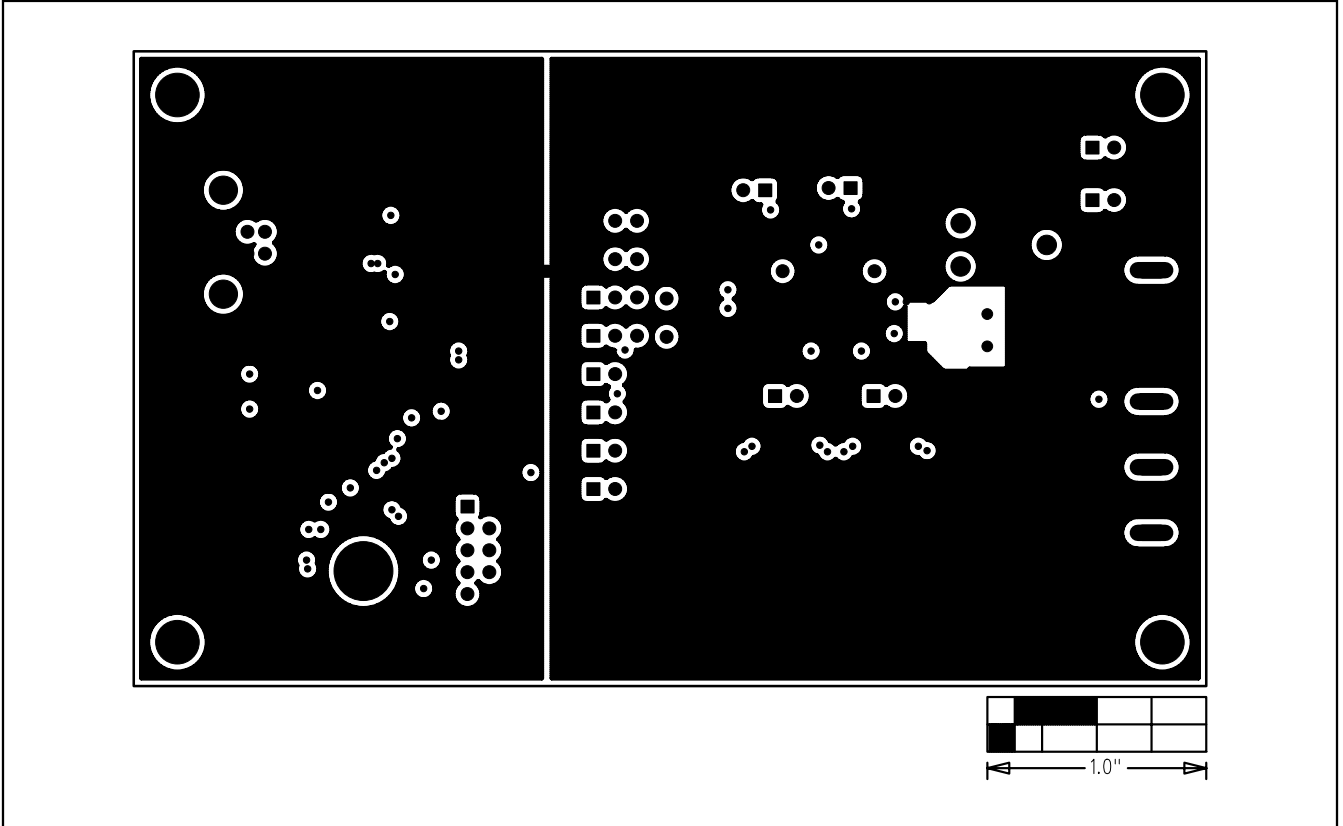

Figure 9. MAX9450 EV Kit PCB Layout—Inner Layer 2

# MAX9450 Evaluation Kit

**Evaluates: MAX9450/MAX9451/MAX9452**

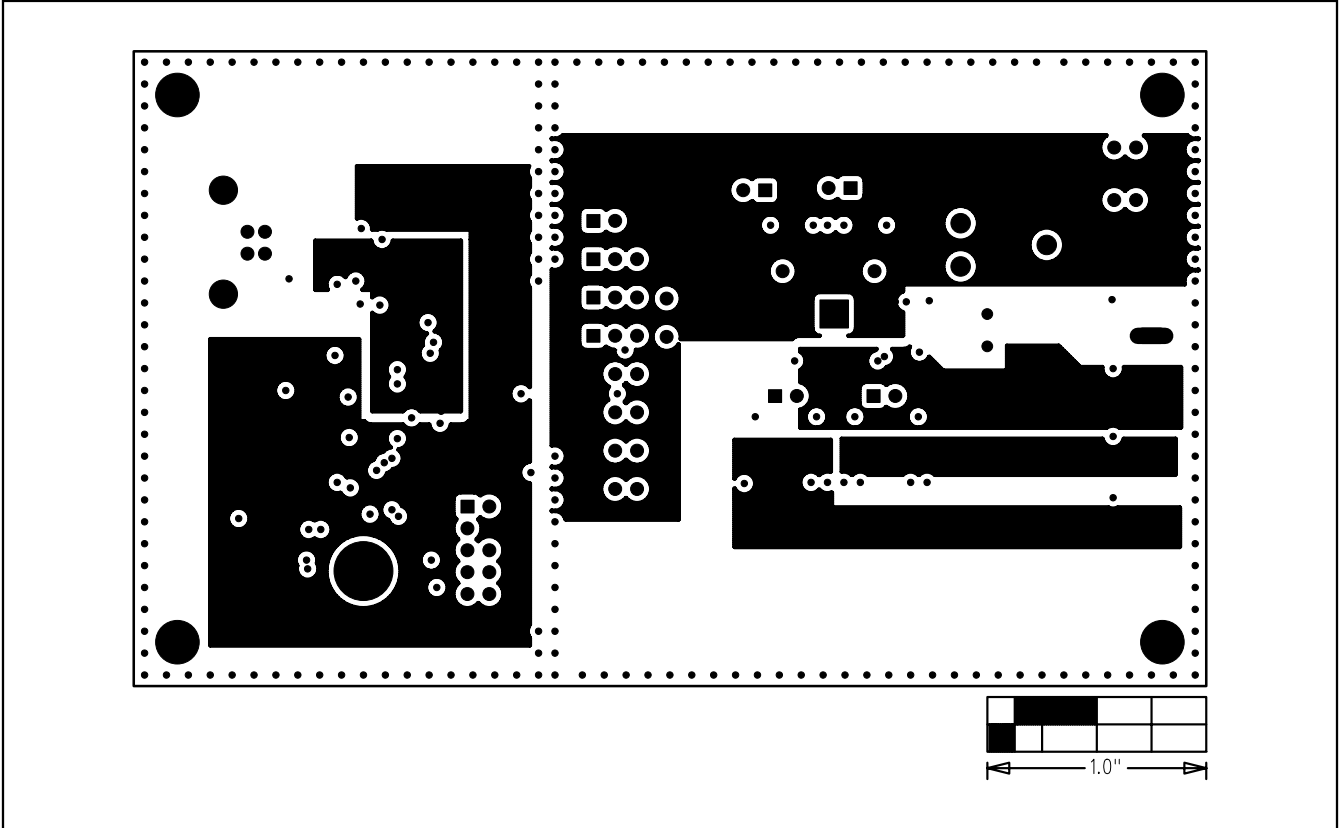

Figure 10. MAX9450 EV Kit PCB Layout—Inner Layer 3

# MAX9450 Evaluation Kit

Evaluates: MAX9450/MAX9451/MAX9452

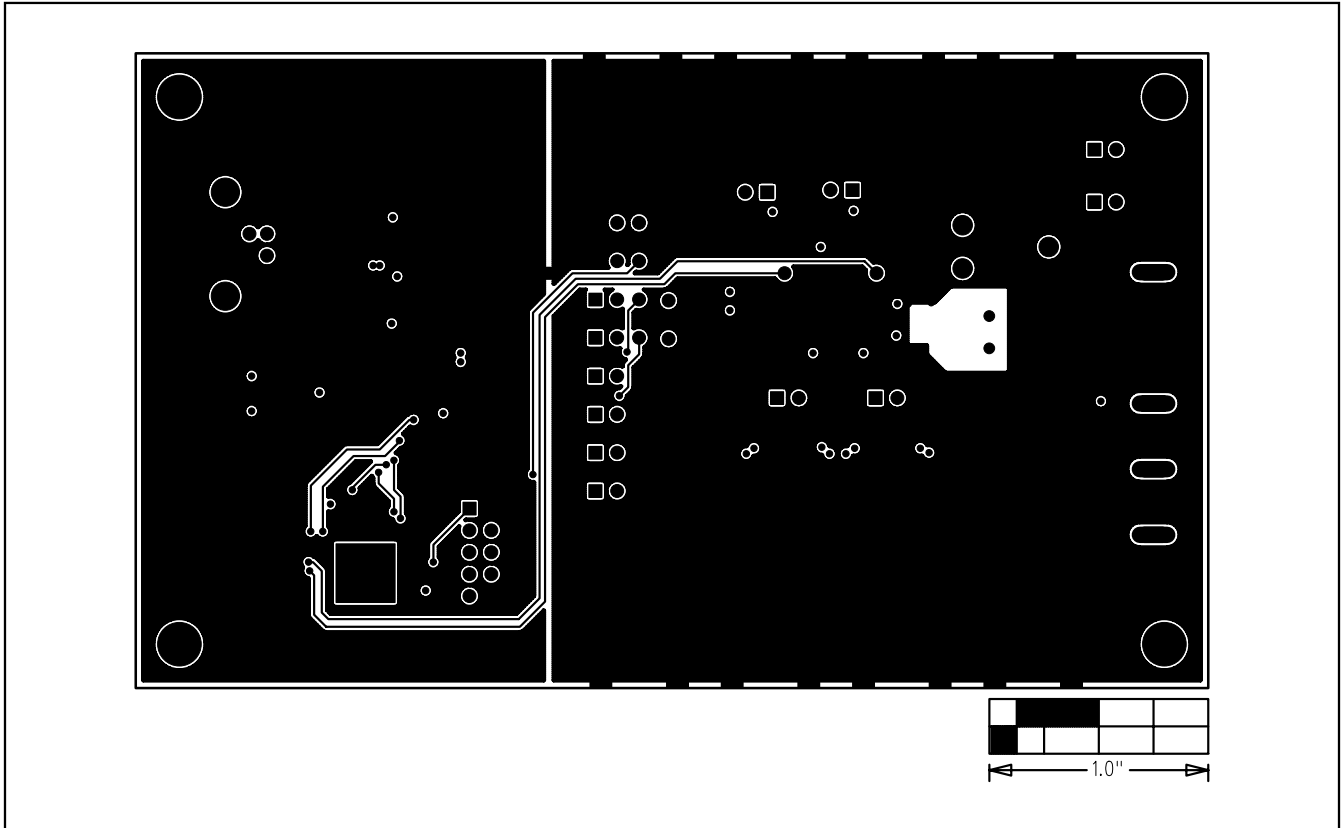

Figure 11. MAX9450 EV Kit PCB Layout—Solder Side

Maxim cannot assume responsibility for use of any circuitry other than circuitry entirely embodied in a Maxim product. No circuit patent licenses are implied. Maxim reserves the right to change the circuitry and specifications without notice at any time.

Maxim Integrated Products, 120 San Gabriel Drive, Sunnyvale, CA 94086 408-737-7600 \_\_\_\_\_ 15