

# MAXIM

## MAX9315 Evaluation Kit

### General Description

The MAX9315 evaluation kit (EV kit) includes the MAX9315, a 1-to-5 low-skew differential clock driver with two differential clock inputs. The MAX9315 EV kit accepts one or two LVECL/LVPECL or HSTL differential inputs and reproduces the selected input at five differential outputs. The EV kit operates up to 1.5GHz. Inputs can be single ended by connecting the on-chip V<sub>BB</sub> reference to one side of a differential input.

The MAX9315 EV kit can be modified to evaluate the MAX9316. The MAX9316 has one differential clock input and one single-ended input.

### Features

- ◆ Controlled 50Ω Microstrip Traces
- ◆ Input Trace Lengths Matched to <2mils
- ◆ Output Trace Lengths Matched to <1mil
- ◆ Board Frequency: Up to 1.5GHz
- ◆ 2.375V (V<sub>CC</sub> - V<sub>EE</sub>) Supply Voltage
- ◆ 20-Pin TSSOP Package
- ◆ Fully Assembled and Tested

### Ordering Information

PART	TEMP RANGE	IC PACKAGE
MAX9315EVKIT	0°C to +70°C	20 TSSOP

**Note:** To evaluate the MAX9316, request a MAX9316EUP free sample with the MAX9315EVKIT.

### Component List

DESIGNATION	QTY	DESCRIPTION
C1, C2	2	10μF ±10%, 10V tantalum capacitors (Case B) AVX TAJB106K010R or Kemet T494B106K010AS
C3, C4, C5	3	0.1μF ±10%, 16V X7R ceramic chip capacitors (0603) Taiyo Yuden EMK107BJ104KA or Murata GRM39X7R104K016AD
C6-C9	4	0.01μF ±10%, 16V X7R ceramic chip capacitors (0402) Taiyo Yuden EMK105BJ103KW or Murata GRM36X7R103K016AD
C10	0	Not installed, capacitor (0402)
JU1, JU2	2	3-pin jumpers
R1, R2	0	Not installed, resistor (0402)
R3-R10	8	49.9Ω ±1% resistors (0402)

DESIGNATION	QTY	DESCRIPTION
R11, R12	0	Not installed, resistor (1210)
R13-R22	10	100Ω ±1% 1/4W resistors (1210) Digi-Key P100AACT-ND or equivalent
Q0, $\overline{Q0}$ , Q1, $\overline{Q1}$ , Q2, $\overline{Q2}$ , Q3, $\overline{Q3}$ , Q4, $\overline{Q4}$ , CLK0, $\overline{CLK0}$ , CLK1, $\overline{CLK1}$ , VBB	15	SMA edge-mount connectors Digi-Key J502-ND
CLKSEL	0	Not installed, SMA edge-mount connector
U1	1	MAX9315EUP (20-pin TSSOP)
None	2	Shunts
None	1	MAX9315 PC board
None	1	MAX9315 EV kit data sheet
None	1	MAX9315 data sheet

# MAX9315 Evaluation Kit

## Component Suppliers

SUPPLIER	PHONE	FAX	WEBSITE
AVX	843-946-0238	843-626-3123	www.avxcorp.com
Kemet	864-963-6300	864-963-6322	www.kemet.com
Murata	770-436-1300	770-436-3030	www.murata.com
Taiyo Yuden	800-348-2496	847-925-0899	www.t-yuden.com

**Note:** Please indicate that you are using the MAX9315/MAX9316 when contacting these component suppliers.

### Quick Start

The MAX9315 EV kit is fully assembled and tested. **Do not turn on the power supplies until all connections are completed.**

#### Recommended Equipment

- One 1.5GHz (min) differential signal generator (e.g., Agilent 8133A)
- One 8GHz (min) bandwidth oscilloscope with internal 50Ω input termination (e.g., Tektronix 11801C digital sampling oscilloscope with SD-24 sampling head)
- Two power supplies
  - a) One 2V ± 0.05V with 500mA current capability
  - b) One adjustable -1.8V to -0.375V with 500mA current capability
- Matched male-SMA-to-male-SMA 50Ω coax cables
  - a) Matched SMA 50Ω coax cables for input CLK0 and  $\overline{\text{CLK0}}$
  - b) Matched SMA 50Ω coax cables for output Q0 and  $\overline{\text{Q0}}$

#### Evaluating the MAX9315 with One Differential Input

- 1) Verify that shunts are across pins 2 and 3 of jumper JU1 ( $\overline{\text{EN}}$ ), and pins 2 and 3 of jumper JU2 (CLKSEL).
- 2) Connect two matched coax cables to the oscilloscope. Connect the other end of the cables to Q0 and  $\overline{\text{Q0}}$  on the EV kit board.

- 3) Connect a 2.0V power supply to the VCC pad. Connect the supply ground to the GND pad closest to VCC.
- 4) Connect a -1.3V adjustable power supply to the pad labeled VEE. Connect the supply ground to the GND pad closest to VEE.
- 5) Adjust the differential signal generator to the following settings:
  - a)  $V_{IH} = 1.0V$
  - b)  $V_{IL} = 0.3V$
  - c) Duty cycle = 50%
  - d) Frequency = 1.5GHz
- 6) Connect one pair of matched coax cables to the differential signal generator. Connect the other end of the cables to CLK0 and  $\overline{\text{CLK0}}$  on the EV kit.
- 7) Turn on the power supplies, enable the generator, and verify that the output signals meet the following specifications:
  - a)  $V_{OH}: 0.855V < V_{OH} < 1.135V$
  - b)  $V_{OL}: 0.055V < V_{OL} < 0.305V$
  - c)  $V_{OH} - V_{OL}: 550mV < (V_{OH} - V_{OL}) < 910mV$

#### Notes:

- 1) To verify output signals other than Q0 and  $\overline{\text{Q0}}$ , remove the corresponding 50Ω output termination resistor, and make sure the untested output signals are terminated with 50Ω resistors.
- 2) For other input levels, refer to the MAX9315 and MAX9316 data sheets, setting VCC = 2.0V.
- 3) To evaluate the MAX9316, see the *Evaluating the MAX9316* section.

# MAX9315 Evaluation Kit

Evaluates: MAX9315/MAX9316

## Detailed Description

### Power Supply

In order to terminate outputs with  $50\Omega$  to  $(V_{CC} - 2V)$  using the  $50\Omega$  oscilloscope input,  $V_{CC}$  is set to 2.0V. In an actual application,  $V_{CC}$  and  $V_{EE}$  can have different supplies; refer to the MAX9315 and MAX9316 data sheets.

$V_{BB}$  is an on-chip reference output voltage. Connect  $V_{BB}$  to the inverting or noninverting clock input to provide a reference for single-ended operation. For  $V_{CC} = 2.0V$ , the MAX9315 EV kit provides a  $V_{BB}$  from 0.475V to 0.675V.

### Enable

The MAX9315 EV kit features a DC logic-level  $\overline{EN}$  function using jumper JU1. Table 1 shows the  $\overline{EN}$  settings and its corresponding functions.

**Table 1. Jumper JU1 Functions**

SHUNT LOCATION	$\overline{EN}$ PIN	MAX9315 FUNCTION
1 and 2	Connect to $V_{CC}$	MAX9315 output disable
2 and 3	Connect to $V_{EE}$	MAX9315 output enable

### Clock Select

Input CLKSEL pin selects channel 0 (CLK0 and  $\overline{CLK0}$ ) or channel 1 (CLK1 and  $\overline{CLK1}$ ). The MAX9315 EV kit can either provide an internal DC select signal by using jumper JU2, or accept an AC external signal from an SMA connector CLKSEL. **(Before connecting the external signal to the CLKSEL connector, verify there is no shunt across jumper JU2).** Table 2 shows the functions of jumper JU2.

### Evaluating the MAX9316

The MAX9315 EV kit can also be used to evaluate the MAX9316, which has one differential LVECL/LVPECL, HSTL input, or single-ended input for scan clock. To evaluate the MAX9316, the following modifications have to be made:

- 1) Replace the MAX9315EUP with the MAX9316EUP.
- 2) Remove R19, R20, and C8.
- 3) Add  $100\Omega$  resistors on R11 and R12 and a  $0.01\mu F$  capacitor on C10.

**Table 2. Jumper JU2 Functions**

SHUNT LOCATION	CLKSEL PIN	INPUT SOURCE
1 and 2	Connect to $V_{CC}$	CLK1 and $\overline{CLK1}$
2 and 3	Connect to $V_{EE}$	CLK0 and $\overline{CLK0}$
No shunt	Driven by external AC signal	Selected by AC signal level

# MAX9315 Evaluation Kit

Evaluates: MAX9315/MAX9316

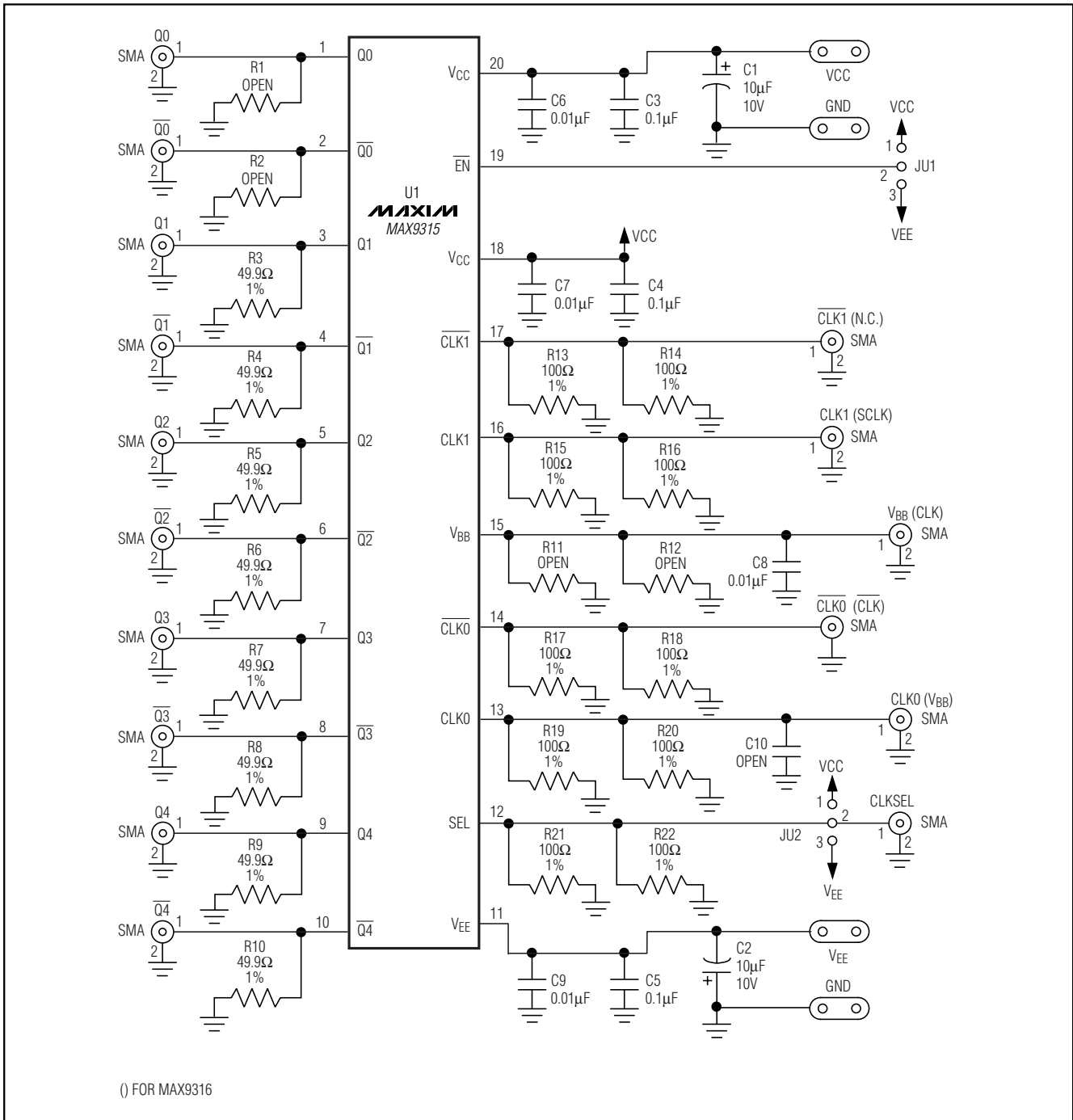

Figure 1. MAX9315 EV Kit Schematic

# MAX9315 Evaluation Kit

Evaluates: MAX9315/MAX9316

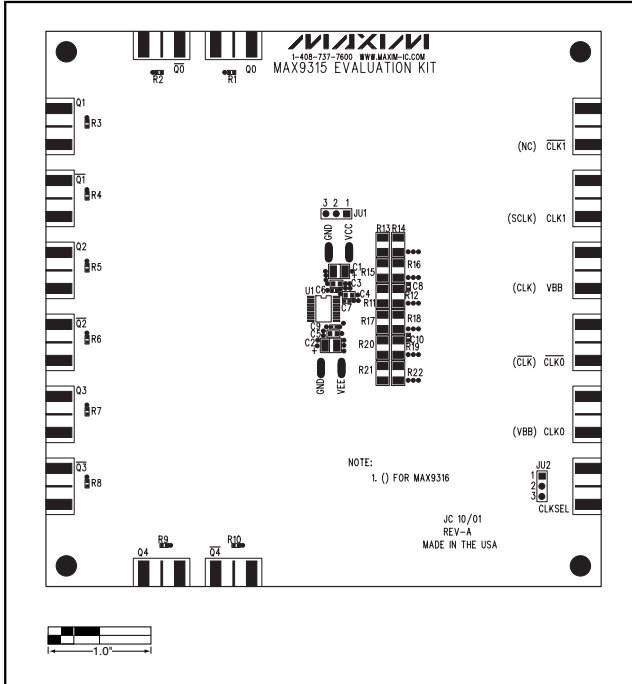

Figure 2. MAX9315 EV Kit Component Placement Guide—Component Side

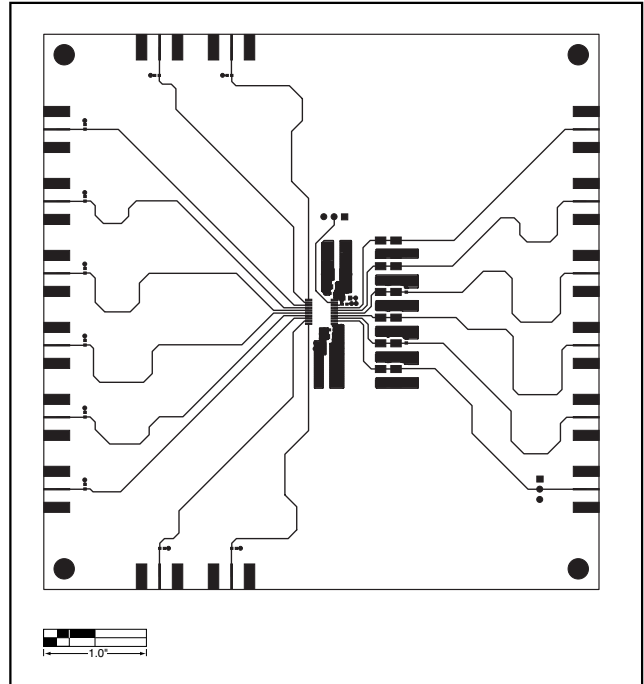

Figure 3. MAX9315 EV Kit PC Board Layout—Component Side

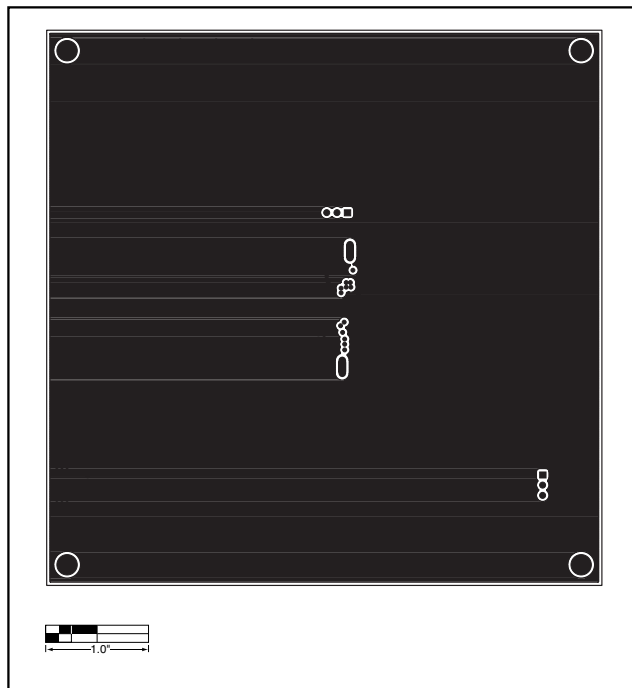

Figure 4. MAX9315 EV Kit PC Board Layout—Inner Layer 2 (Ground Layer)

# MAX9315 Evaluation Kit

Evaluates: MAX9315/MAX9316

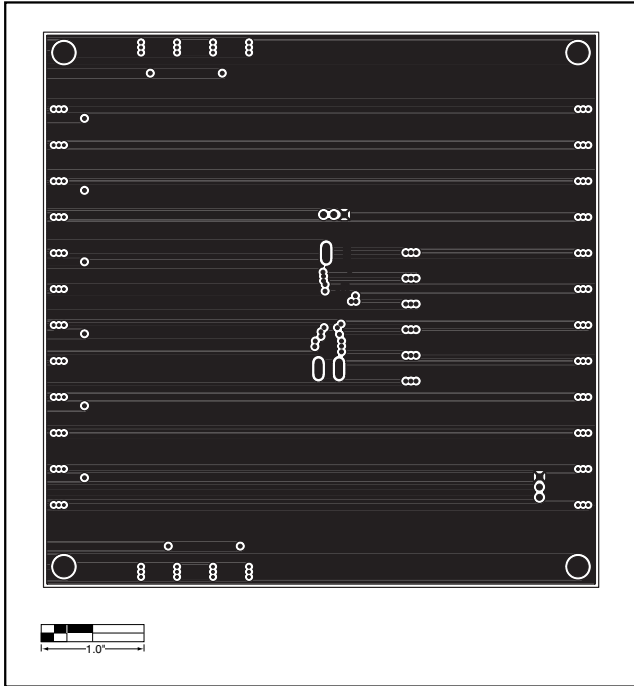

Figure 5. MAX9315 EV Kit PC Board Layout—Inner Layer 3 (Vcc Layer)

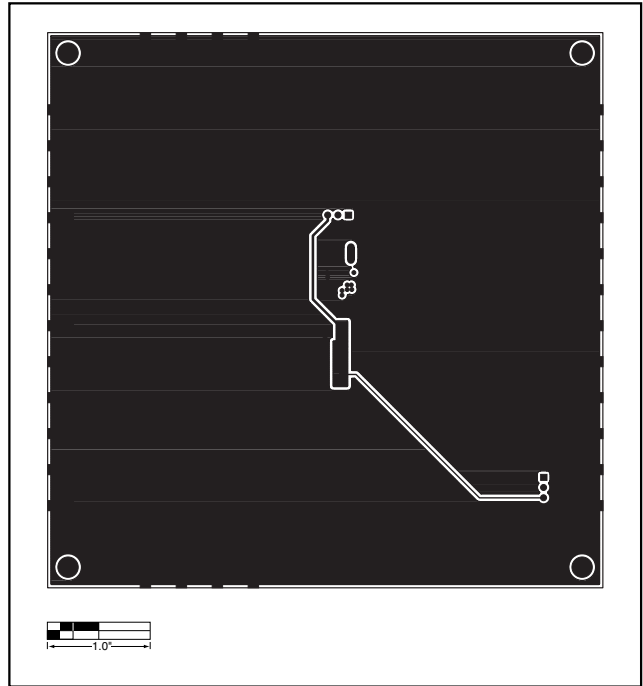

Figure 6. MAX9315 EV Kit PC Board Layout—Solder Side

Maxim cannot assume responsibility for use of any circuitry other than circuitry entirely embodied in a Maxim product. No circuit patent licenses are implied. Maxim reserves the right to change the circuitry and specifications without notice at any time.

6 \_\_\_\_\_ **Maxim Integrated Products, 120 San Gabriel Drive, Sunnyvale, CA 94086 408-737-7600**