



MAX8808 Evaluation Kit

General Description

The MAX8808 evaluation kit (EV kit) is a fully assembled and tested circuit board that demonstrates the highly integrated MAX8808X/MAX8808Y/MAX8808Z linear battery chargers for single-cell lithium-ion (Li+) batteries. The EV kit safely charges a single Li+ battery to 4.2V. The EV kit accepts power supply inputs of 4.25V to 15V, but disables charging when the input voltage exceeds 7V. An enable input to the EV kit allows the user to disable and enable the charger. An LED on the board indicates the status of the charging cycle.

Component List

DESIGNATION	QTY	DESCRIPTION
C1	1	1 μ F, 16V X5R ceramic capacitor (0603) Murata GRM188R61C105KA93
C2	1	0.47 μ F, 6.3V X5R ceramic capacitor (0402) Murata GRM155R60J474KE19
C3	1	1 μ F, 6.3V X5R ceramic capacitor (0402) Murata GRM155R60J105KE19
C4	0	Not installed
D1	1	Small SMD green LED (0805) Chicago Miniature 7012X5 Mouser 606-7012X5
JU1	1	3-pin header
R1	1	2.8k Ω \pm 1% resistor (0402)
R2	1	100k Ω resistor (0402)
R3	1	300 Ω \pm 5% resistor (0402)
R4	0	Not installed, PC board trace short
U1	1	MAX8808XETA (8-pin TDFN 2mm x 2mm)
—	1	Shunt, installed on JU1 Digikey S9000-ND or equivalent
—	1	MAX8808 EV kit PC board

Features

- ◆ Simple Stand-Alone Li+ Charger
- ◆ Safely Precharges Deeply Discharged Li+ Cells (MAX8808X)
- ◆ 4.25V to 15V Input Voltage Range
- ◆ 7V Overvoltage-Protection Threshold
- ◆ Resistor-Programmable Charge Current Up to 1A
- ◆ Charge-Current Monitor by a Resistor
- ◆ +115°C Die Temperature Regulation
- ◆ ACOK Output
- ◆ No Prequalification (MAX8808Y/MAX8808Z)
- ◆ Soft-Start
- ◆ Tiny 2mm x 2mm, 8-Pin TDFN Package
- ◆ Fully Assembled and Tested

Ordering Information

PART	TEMP RANGE	IC PACKAGE
MAX8808EVKIT	0°C to +70°C	8 TDFN (2mm x 2mm)

Component Suppliers

SUPPLIER	PHONE	WEBSITE
Murata	770-436-1300	www.murata.com
Panasonic	714-373-7366	www.panasonic.com
Taiyo Yuden	800-348-2496	www.t-yuden.com
TDK	847-803-6100	www.component.tdk.com

Note: Indicate you are using the MAX8808X/Y/Z when contacting these manufacturers.

Evaluates: MAX8808X/MAX8808Y/MAX8808Z

MAX8808 Evaluation Kit

Recommended Equipment

- Variable 6V power supply
- Digital multimeter
- One-cell lithium-ion battery

Quick Start

The MAX8808 EV kit is a fully assembled and tested surface-mount board. Follow the steps below to verify board operation:

- 1) Preset the power supply to 5V. Turn off the power supply. **Do not turn on the power supply until all connections are made.**
- 2) Verify that the shunt is between pins 2 and 3 of jumper JU1 (EN) to set the EV kit for charge default enable mode.
- 3) Connect the positive lead of the power supply to the VIN pad on the EV kit. Connect the negative lead of the power supply to the GND pad on the EV kit.
- 4) Connect the digital multimeter from BATT+ to BATT-.
- 5) Turn on the power supply. Verify that the voltage is 4.2V at BATT+.
- 6) **Observe correct Li+ cell polarity.** Connect a single-cell Li+ battery across the BATT+ and BATT- pads of the EV kit.
- 7) Verify that the green LED (D1) turns on. The green LED turns on during prequalification and fast-charge conditions. The green LED turns off when the battery-charging current drops to 10% of the fast-charging current.

Detailed Description

Input Source

The MAX8808 EV kit requires a power supply with an output voltage between 4.25V and 6.5V for proper operation. The MAX8808_ charger is designed to handle a maximum input voltage of 15V, but it disables charging when the input voltage exceeds the overvoltage-protection threshold of 7V or when the input voltage minus the battery voltage is less than 40mV.

VL

The MAX8808_ linear chargers contain an internal linear regulator (VL). The VL output is regulated to 3.0V whenever the input voltage is above 3V and 40mV greater than the battery voltage.

Fast-Charge Current

The maximum battery-charge current is programmed by R1, which is connected between ISET and GND. The EV kit's fast-charging current is set to 465mA with the installed 2.8k Ω resistor. To reconfigure the charging current, use the following equation to select a new value for R1:

$$R1 = 930 \times 1.4V / I_{CHARGE}$$

where R1 is in ohms and I_{CHARGE} is in amps.

Temperature Self-Regulation

The MAX8808_ has a fixed die-temperature-regulation point of +115°C. During charging, if the die temperature approaches +115°C, the charger reduces the charging current to keep the die temperature from exceeding +115°C.

Charge Profile

The MAX8808_ charger uses voltage, current, and thermal control loops to facilitate charging of a single Li+ cell and protect the battery. When a Li+ battery with a cell voltage below 2.5V is inserted, the MAX8808X charger enters the prequalification stage where it precharges that cell with 10% of the user-programmed fast-charge current. Once the cell voltage has passed 2.5V, the charger soft-starts as it enters the fast-charge stage. The MAX8808Y and MAX8808Z do not have the prequalification stage, and therefore, soft-start to the fast-charge level immediately when enabled. The fast-charge current level is programmed using a resistor from ISET to GND (R1). The installed green LED indicates charging. As the battery voltage approaches 4.2V, charging current is reduced. When the battery current drops to 10% of the fast-charging current, the green LED turns off, signaling that the charging is done. If, at any point while charging the battery, the die temperature approaches +115°C, the MAX8808_ reduces the charging current to limit the die temperature to +115°C.

MAX8808 Evaluation Kit

Disabling the Charger

The EV kit contains JU1 to enable or disable the charger. The MAX8808X and MAX8808Z use an active-low enable input (\overline{EN}). Install a shunt between pins 1 and 2 of JU1 to drive \overline{EN} high and disable the charger and terminate the charging cycle. VL is active during shut-down. Install a shunt between positions 2 and 3 of JU1 to drive \overline{EN} low to enable the IC. The MAX8808Y uses an active-high enable. Drive EN high to enable the charger. Drive EN low to disable the charger.

CHG

The green LED (D1) is a visual indicator of the charging status of the EV kit. Table 1 describes the state of the green LED during normal operation.

Table 1. \overline{CHG} States

CHARGE MODE	GREEN LED (CHG)	CONDITIONS
Charging	On (logic-low)	Prequalification, fast-charge
Charge complete	Off (high impedance)	Top-off charge
Disable mode	Off (high impedance)	Charger is off

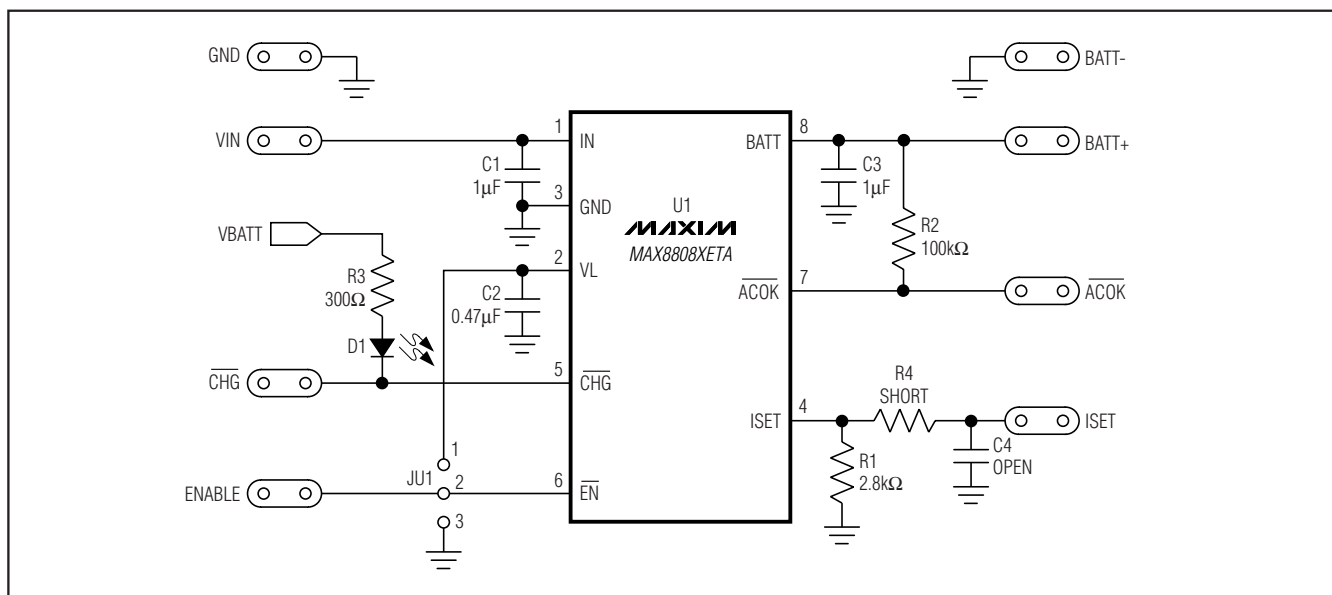

Figure 1. MAX8808 EV Kit Schematic

Evaluates: MAX8808X/MAX8808Y/MAX8808Z

MAX8808 Evaluation Kit

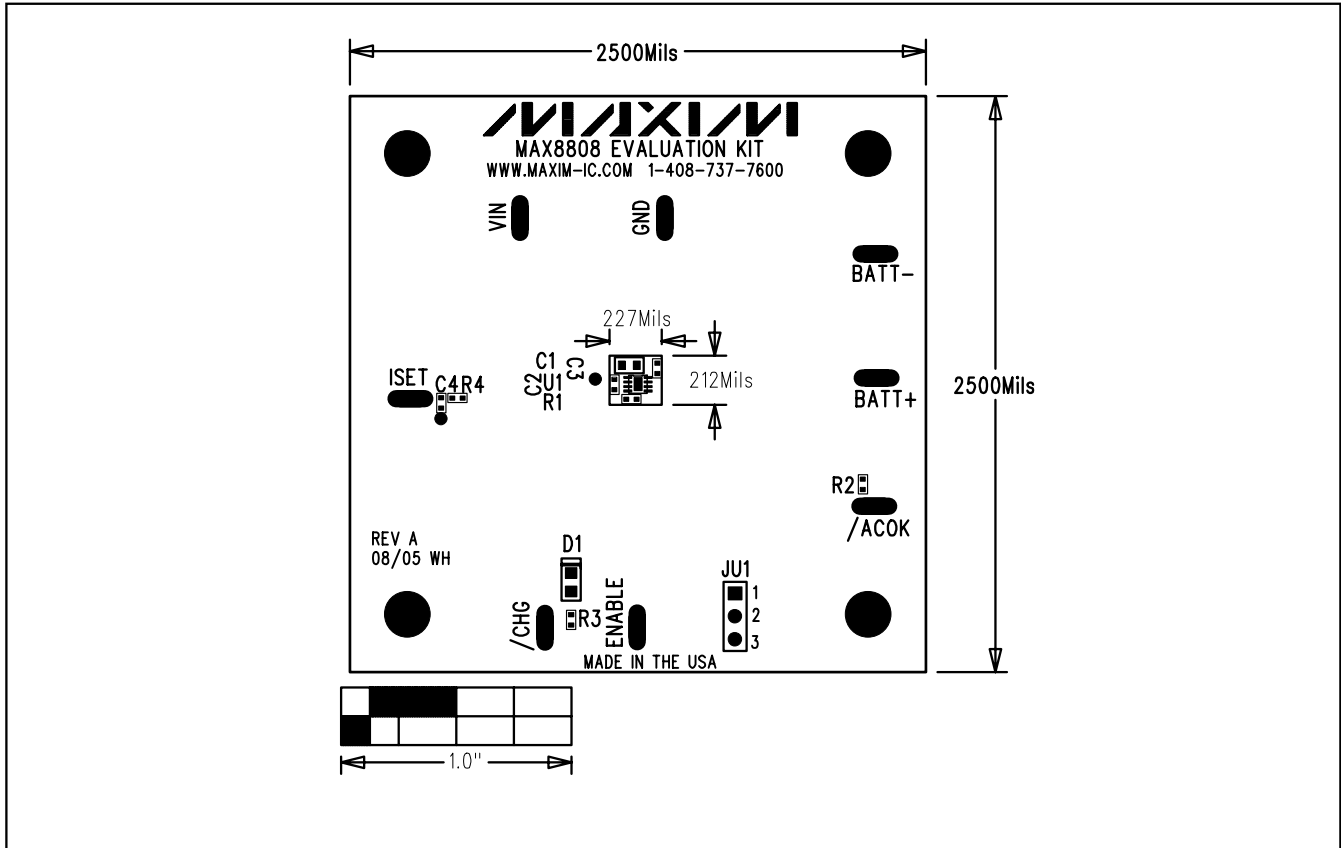

Figure 2. MAX8808 EV Kit Component Placement Guide—Component Side

MAX8808 Evaluation Kit

Evaluates: MAX8808X/MAX8808Y/MAX8808Z

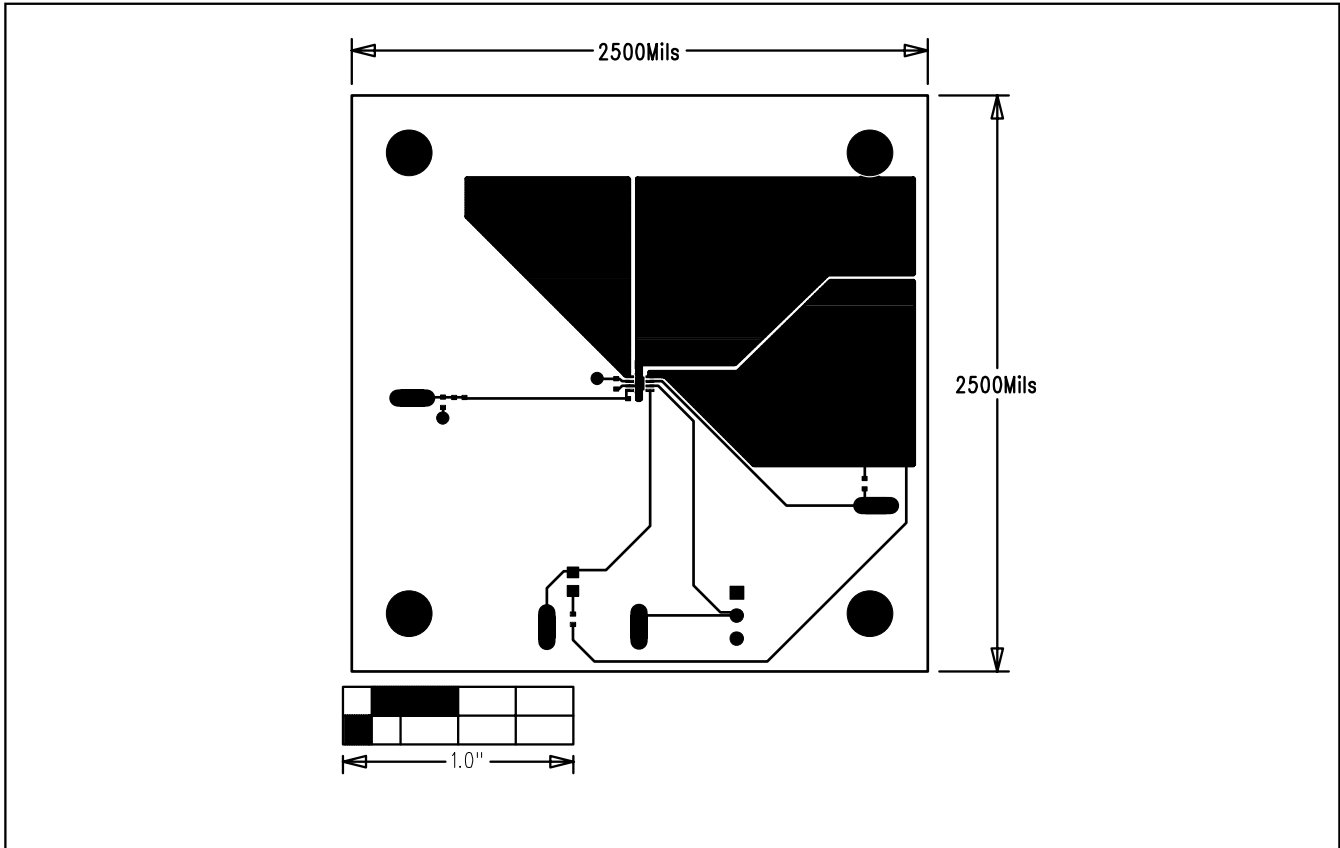

Figure 3. MAX8808 EV Kit PC Board Layout—Component Side

MAX8808 Evaluation Kit

Evaluates: MAX8808X/MAX8808Y/MAX8808Z

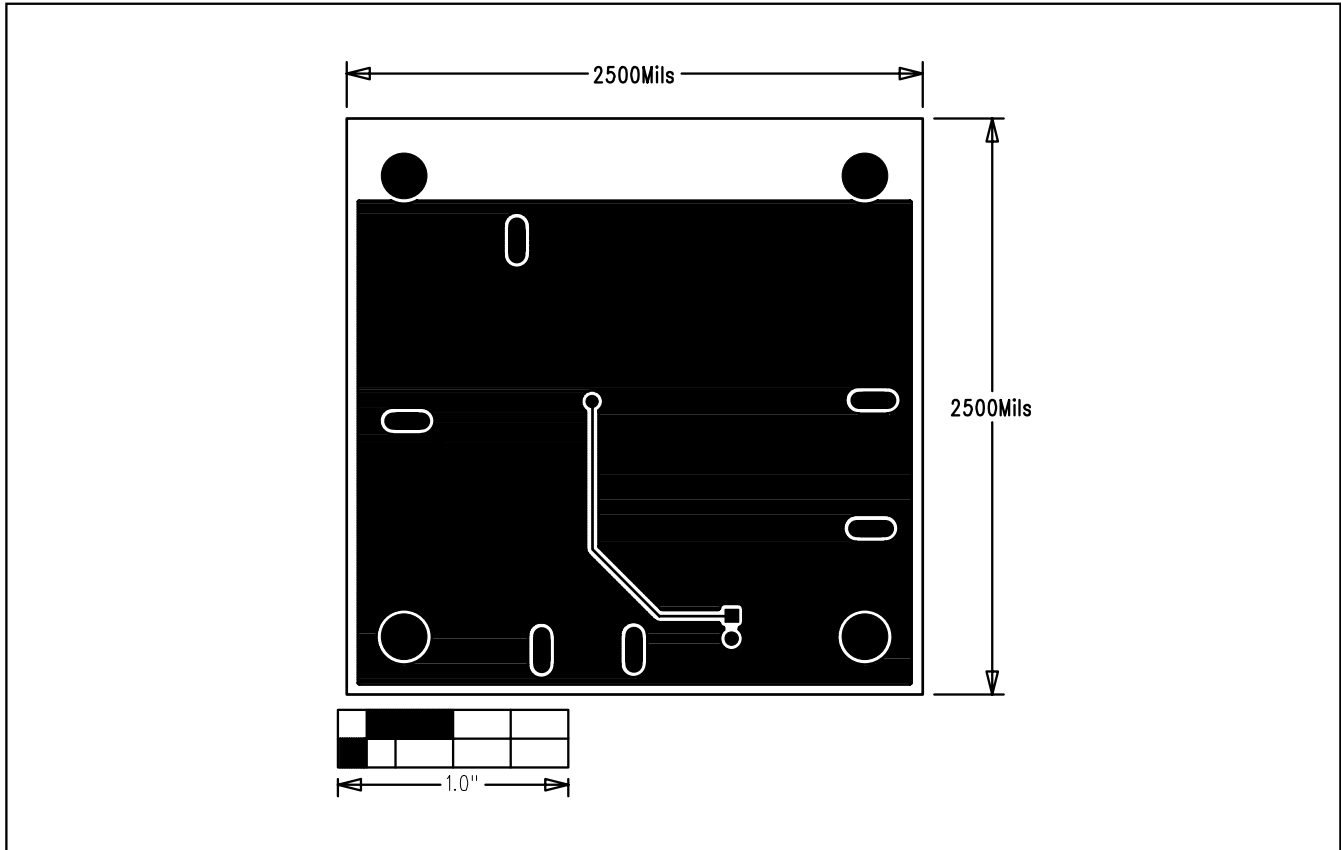

Figure 4. MAX8808 EV Kit PC Board Layout—Solder Side

Maxim cannot assume responsibility for use of any circuitry other than circuitry entirely embodied in a Maxim product. No circuit patent licenses are implied. Maxim reserves the right to change the circuitry and specifications without notice at any time.

6 _____ **Maxim Integrated Products, 120 San Gabriel Drive, Sunnyvale, CA 94086 408-737-7600**

© 2005 Maxim Integrated Products

Printed USA

MAXIM is a registered trademark of Maxim Integrated Products, Inc.