



MAX8744A Evaluation Kit

General Description

The MAX8744A evaluation kit (EV kit) demonstrates the MAX8744A's standard application circuit. This dual-PWM synchronous DC-DC converter steps down high-voltage batteries and/or AC adapters, generating main supplies for notebook computers. The MAX8744A EV kit provides dual 5V and 3.3V output voltages from a 7V to 24V battery input range. It delivers up to 6A output current for the 5V output and 5A for the 3.3V output with 97% efficiency. Both outputs are adjustable between 2V and 5.5V by changing feedback resistors R17–R20.

A transformer on the 5V output and a postregulation LDO generates a 12V auxiliary voltage capable of delivering 120mA. This auxiliary voltage is adjustable between 1V and 23V by changing feedback resistors R3 and R4.

The MAX8744A also has an internal fixed 5V linear regulator capable of supplying 100mA.

The MAX8744A EV kit operates at 300kHz switching frequency.

Features

- ◆ 7V to 24V Input Range
- ◆ Internal 5V Linear Regulator with 100mA Load Capability
- ◆ Output Voltages
 - 3.3V at 6A (Adjustable from 2V to 5.5V)
 - 5V at 5A (Adjustable from 2V to 5.5V)
 - 12V at 120mA (Adjustable from 1V to 23V)
- ◆ 300kHz Switching Frequency (Selectable 200kHz/300kHz/500kHz)
- ◆ Power-Good Outputs
- ◆ Over- and Undervoltage Protection
- ◆ 32-Pin Thin QFN Package
- ◆ Fully Assembled and Tested

Ordering Information

PART	TYPE
MAX8744AEVKIT+	EV Kit

+Denotes lead-free and RoHS-compliant.

Component List

DESIGNATION	QTY	DESCRIPTION
C1, C2	2	10 μ F \pm 20%, 25V X5R ceramic capacitors (1210) TDK C3225X7R1E106M AVX 12103D106M Taiyo Yuden TMK325BJ106MM
C3, C4	0	Not installed (1210)
C5, C10	2	150 μ F, 4V, 35m Ω low-ESR capacitors (B-case) SANYO 4TPE150MAZB
C6, C7	2	100 μ F, 6.3V, 35m Ω low-ESR capacitors (B-case) SANYO 6TPE100MAZB
C8, C9, C11, C12	4	0.1 μ F \pm 10%, 25V X7R ceramic capacitors (0603) Murata GRM188R71E104K TDK C1608X7R1E104K
C13	0	Not installed (1206)

DESIGNATION	QTY	DESCRIPTION
C14	1	1 μ F \pm 10%, 25V X7R ceramic capacitor (1206) Murata GRM31MR71E105K Taiyo Yuden TMK316BJ105KL TDK C3216X7R1E105K
C15	1	4.7 μ F \pm 10%, 6.3V X5R ceramic capacitor (0805) TDK C2012X5R0J475K or Taiyo Yuden JMK212BJ475KG
C16, C17	2	4.7 μ F \pm 10%, 25V X7R ceramic capacitors (1210) TDK C3325X7R1E475K
C18, C19	2	0.15 μ F \pm 20%, 16V X5R ceramic capacitors (0603) TDK C1608X7R1E154K or Taiyo Yuden EMK107BJ154KA

Evaluates: MAX8744A/MAX8745A

MAX8744A Evaluation Kit

Component List (continued)

DESIGNATION	QTY	DESCRIPTION	
C20	1	0.22 μ F \pm 10%, 16V X7R ceramic capacitor (0603) Taiyo Yuden EMK107BJ224KA TDK C1608X7R1C224K	
C21, C22	2	1000pF \pm 10%, 50V X7R ceramic capacitors (0603) TDK C1608X7R1H102K or Murata GRM188R71H102K	
D1, D2	0	Not installed Schottky diodes, 2A, 30V, SMA Central Semi CSMH2-40M Diodes Inc. B230A	Top mark: CS240M B230A
D3	1	Fast-recovery diode, 1A, 200V, SMB Central Semi CMR1S-02 Diodes Inc. MURS120 Nihon EC11FS2	Top mark: CSF02 U1DB
JU1–JU4	4	3-pin headers	
JU5, JU6	2	4-pin headers	
L1	1	5.8 μ H, 8.6A, 16.2m Ω inductor Sumida CDRH127/LD-5R8NC or Cooper Electronic Technologies CTX03-17204 or Pulse P1172.582	
N1, N3	2	n-channel MOSFETs, 8.4A, 30V (8-pin SO) Fairchild Semiconductor FDS6612A	
N2, N4	2	n-channel MOSFETs, 13A, 30V (8-pin SO) Fairchild Semiconductor FDS6670A	
Q1	1	pnp transistor (3-pin SuperSOT) Fairchild Semiconductor FSB749	

DESIGNATION	QTY	DESCRIPTION
Q2	0	Not installed pnp transistor (3-pin SuperSOT)
R1, R2	0	Not installed (short PC trace) 0.5W sense resistors (2010)
R3	1	110k Ω \pm 1% resistor (0603)
R4	1	10k Ω \pm 1% resistor (0603)
R5	1	680 Ω \pm 5% resistor (1206)
R6	0	Not installed (short PC trace) resistor (1206)
R7, R8, R9, R12, R13, R14	0	Not installed (short PC trace) resistors (0603)
R10, R11, R23, R24, R25	5	100k Ω \pm 5% resistors (0603)
R15	1	6.96k Ω \pm 1% resistor (0603)
R16	1	10.50k Ω \pm 1% resistor
R17–R20, R22, R28	0	Not installed, resistors (0603)
R21	1	100k Ω \pm 1% resistor (0603)
R26	1	3.48k Ω \pm 1% resistor (0603)
R27	1	4.02k Ω \pm 1% resistor (0603)
T1	1	Transformer, primary 6.8 μ H, 6.4A, 1:2 Sumida 4749-T132 (CDRH127B style) or Cooper Electronic Technologies CTX03-17203 or Pulse PF0681NL
U1	1	MAX8744AETJ+ (32-pin thin QFN, 5mm x 5mm)
—	6	Shunts
—	1	PCB: MAX8744A Evaluation Kit+

MAX8744A Evaluation Kit

Component Suppliers

SUPPLIER	PHONE	WEBSITE
AVX Corp.	843-448-9411	www.avx.com
Central Semiconductor Corp.	631-435-1110	www.centrasemi.com
Cooper Electronic Technologies	916-941-1117	www.cooperet.com
Diodes, Inc.	805-446-4800	www.diodes.com
Fairchild Semiconductor	888-522-5372	www.fairchildsemi.com
Murata Mfg. Co., Ltd.	770-436-1300	www.murata.com
Nihon Inter Electronics Corp.	847-843-7500	www.niec.co.jp
Pulse Engineering	858-674-8100	www.pulseeng.com
SANYO NA Corp.	619-661-6835	www.sanyodevice.com
Sumida Corp.	847-545-6700	www.sumida.com
Taiyo Yuden	847-925-0888	www.t-yuden.com
TDK Corp.	847-803-6100	www.component.tdk.com

Note: Indicate that you are using the MAX8744A or MAX8745A when contacting these component suppliers.

Quick Start

Recommended Equipment

Before beginning, the following equipment is needed:

- One 7V to 24V, 100W, DC power supply
- Dummy loads capable of sinking 6A
- Three voltmeters
- One oscilloscope

Procedure

The MAX8744A EV kit is a fully assembled and tested surface-mount board. Follow the steps below to verify board operation. **Do not turn on the power supply until all connections are completed:**

- 1) Verify that the shunts are in the following positions:
 - JU1 = 1-2 (MAX8744A enabled)
 - JU2 = 1-2 (12V auxiliary output enabled)
 - JU3 = 1-2 (3.3V main output enabled)
 - JU4 = 1-2 (5V main output enabled)
 - JU5 = 1-3 (300kHz switching frequency)
 - JU6 = 1-4 (forced-PWM mode)
- 2) Connect a voltmeter across the VOUT3 and PGND pads.
- 3) Connect a voltmeter across the VOUT5 and PGND pads.
- 4) Connect a voltmeter across the AUX_LDO_OUT and PGND pads.
- 5) Turn on the power supply.
- 6) Verify that the output voltages are 3.3V, 5V, and 12V.

Detailed Description

3.3V Output Voltage Setting (VOUT3)

The MAX8744A EV kit is shipped with the FB3 connected to VL5 through pullup resistor R10, which sets the VOUT3 voltage to 3.3V.

To change the output voltage to a value between 2V and 5.5V, remove R10 and set R18 equal to $10k\Omega \pm 1\%$. Calculate R17 using the equation:

$$R17 = R18 [(VOUT3 / VFB3) - 1]$$

where $VFB3 = 2V$.

For an output voltage of 2V, place a short across R17 and leave R18 open.

5V Output Voltage Setting (VOUT5)

The MAX8744A EV kit is shipped with the FB5 connected to VL5 through pullup resistor R11, which sets the VOUT5 voltage to 5V.

To change the output voltage to a value between 2V and 5.5V, remove R11 and set R20 equal to $10k\Omega \pm 1\%$. Calculate R19 using the equation:

$$R19 = R20 [(VOUT5 / VFB5) - 1]$$

where $VFB5 = 2V$.

For an output voltage of 2V, place a short across R19 and leave R20 open.

For output voltages other than 3.3V and 5V, refer to the MAX8744A/MAX8745A IC data sheet for proper inductor and output capacitor values.

Evaluates: MAX8744A/MAX8745A

MAX8744A Evaluation Kit

12V Auxiliary Output Voltage Setting (AUX_LDO_OUT)

The MAX8744A EV kit is shipped with the AUXFB connected to R3 and R4. The AUX_LDO_OUT voltage is set to 12V.

To change the output voltage to a value between 1V and 23V, calculate R3 using the equation:

$$R3 = R4 [(V_{AUX_LDO_OUT} / V_{AUXFB}) - 1]$$

where $V_{AUXFB} = 1V$ and R4 is equal to $10k\Omega \pm 1\%$. Refer to the MAX8744A/MAX8745A IC data sheet for instructions on transformer design for auxiliary output voltages higher than 12V.

Jumper Settings

Table 1. Jumper JU1 Functions (SHDN Mode Selection)

JU1	SHDN PIN	MAX8744A OUTPUT
1 and 2	Connected to VIN	MAX8744A enabled; V _{OUT3} (3.3V) depends on JU3; V _{OUT5} (5V) depends on JU4.
1 and 3	Connected to GND	Shutdown mode; V _{OUT3} = 0V and V _{OUT5} = 0V.
Not installed	Connected to SHDN pad	MAX8744A can be driven by an external signal.

Table 2. Jumper JU2 Functions (Output Voltage AUX_LDO_OUT Control)

JU2	ON_AUX PIN	OUTPUT VOLTAGE (AUX_LDO_OUT)
1 and 2	Connected to VL5	AUX_LDO_OUT = 12V, enabled
2 and 3	Connected to GND	AUX_LDO_OUT = 0, disabled

Table 3. Jumper JU3 Functions (Output Voltage V_{OUT3} Control)

JU3	ON3 PIN	OUTPUT VOLTAGE (V _{OUT3})
1 and 2	Connected to VL5	V _{OUT3} = 3.3V, enabled
2 and 3	Connected to GND	V _{OUT3} = 0V, disabled

Table 4. Jumper JU4 Functions (Output Voltage V_{OUT5} Control)

JU4	ON5 PIN	OUTPUT VOLTAGE (V _{OUT5})
1 and 2	Connected to VL5	V _{OUT5} = 5V, enabled
2 and 3	Connected to GND	V _{OUT5} = 0V, disabled

Table 5. Jumper JU5 Functions (Switching-Frequency Selection)

JU5	FSEL PIN	FREQUENCY (kHz)
1 and 2	Connected to GND	200
1 and 3	Connected to REF	300 (as shipped)
1 and 4	Connected to VL5	500

Important: Do not change the operating frequency without first recalculating component values. The switching frequency has a significant effect on the peak current-limit level, MOSFET heating, preferred inductor value, PFM/PWM switchover point, output noise, efficiency, and other critical parameters.

Table 6. Jumper JU6 Functions (SKIP Mode Selection)

JU6	SKIP PIN	OPERATING MODE
1 and 2	Connected to GND	Automatic, high-efficiency, pulse-skipping operation at light loads
1 and 3	Connected to REF	Automatic, low-noise, pulse-skipping operation at light loads
1 and 4	Connected to VL5	Low-noise, forced fixed-frequency PWM operation

MAX8744A Evaluation Kit

Evaluates: MAX8744A/MAX8745A

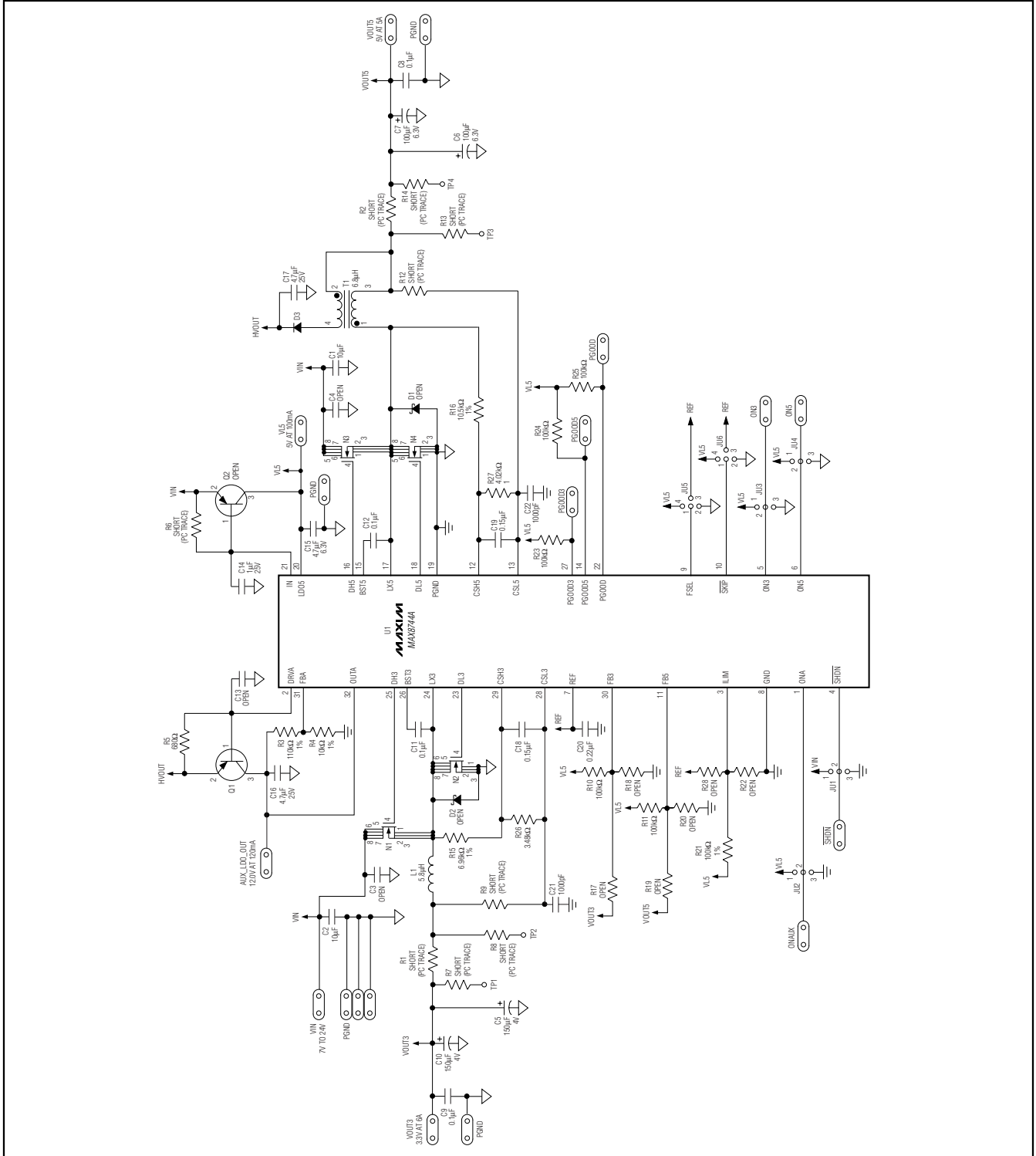

Figure 1. MAX8744A EV Kit Schematic

MAX8744A Evaluation Kit

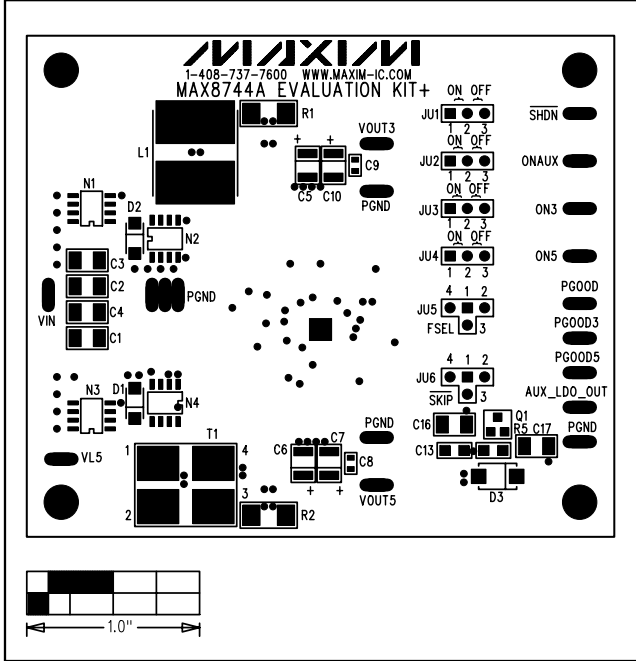

Figure 2. MAX8744A EV Kit Component Placement Guide—Component Side

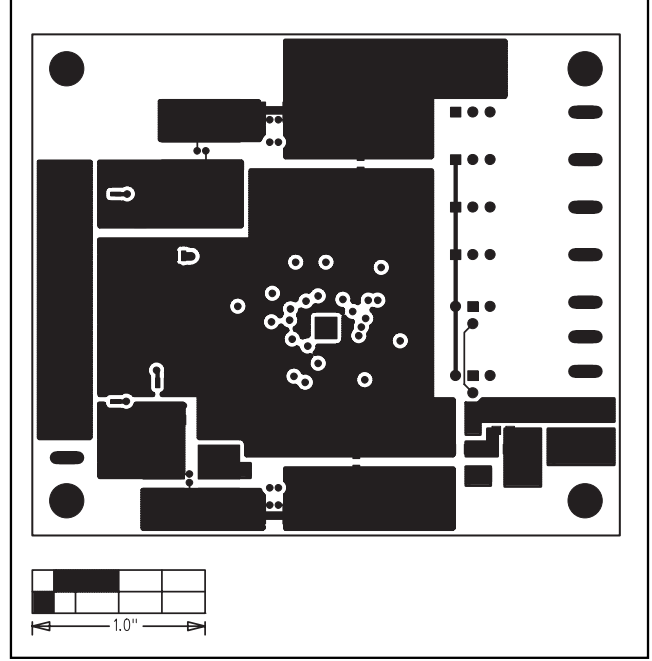

Figure 3. MAX8744A EV Kit PCB Layout—Component Side

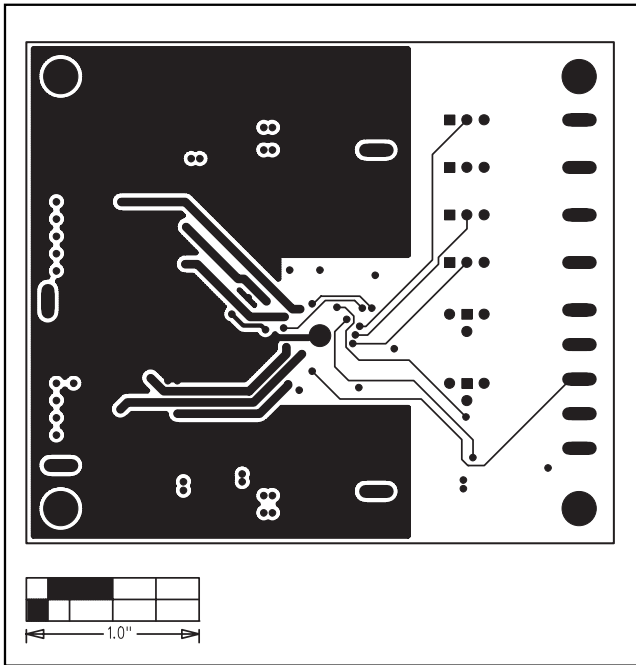

Figure 4. MAX8744A EV Kit PCB Layout—Layer 2

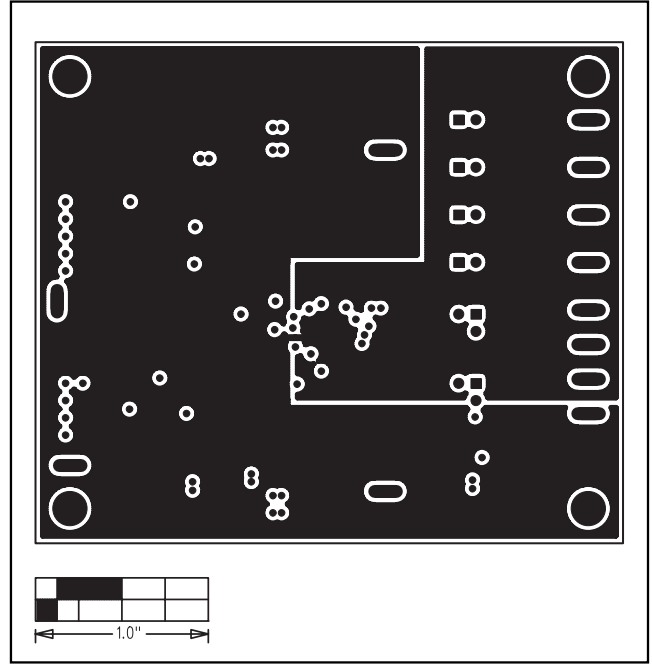

Figure 5. MAX8744A EV Kit PCB Layout—Layer 3

MAX8744A Evaluation Kit

Evaluates: MAX8744A/MAX8745A

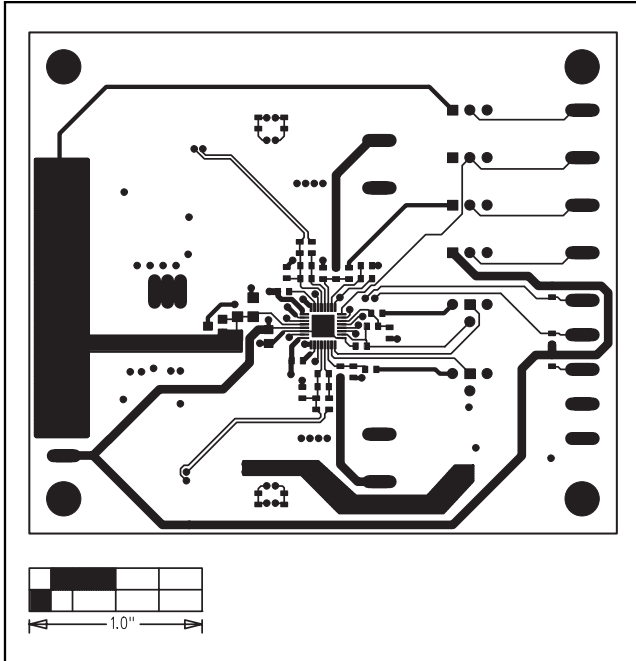

Figure 6. MAX8744A EV Kit PCB Layout—Solder Side

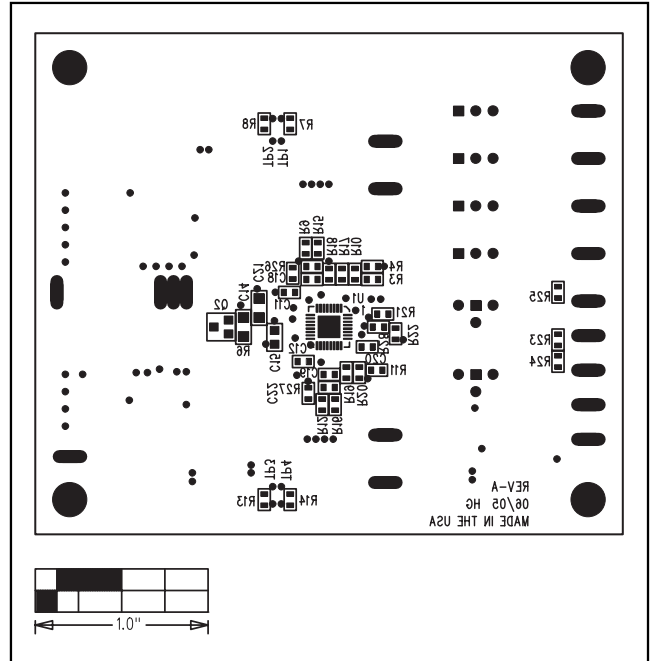

Figure 7. MAX8744A EV Kit Component Placement Guide—Solder Side

Revision History

Pages changed at Rev 1: 1, 2, 3, 5, 6, 7

Pages changed at Rev 2: Title change—all pages, 1–7

Maxim cannot assume responsibility for use of any circuitry other than circuitry entirely embodied in a Maxim product. No circuit patent licenses are implied. Maxim reserves the right to change the circuitry and specifications without notice at any time.

Maxim Integrated Products, 120 San Gabriel Drive, Sunnyvale, CA 94086 408-737-7600 _____ 7