



# MAX8685C Evaluation Kit

## General Description

The MAX8685C evaluation kit (EV kit) is a fully assembled and tested printed-circuit board (PCB) for evaluating the MAX8685C/MAX8685D xenon flash charger family. The MAX8685C EV kit operates from a 2.5V to 5.5V supply and charges a 35 $\mu$ F capacitor to 300V. Battery voltages as low as 1.5V can be used to supply the inductor primary current. The MAX8685C/MAX8685D offer fixed peak primary current limits of 1A and 1.6A, respectively. An LED indicator on the EV kit lights up when the initial charging cycle is complete.

## Features

- ◆ Charges 35 $\mu$ F to 300V
- ◆ EV Kit Includes Xenon Flash Tube, IGBT, and Trigger Transformer
- ◆ No Inrush Current
- ◆ Short-Circuit Protection
- ◆ Robust Architecture Allows Use of Low-Cost Transformers
- ◆ High Accuracy Not Dependent on Transformer Turns Ratio
- ◆ Automatic Refresh Mode Draws Minimal Quiescent Current
- ◆ Charge-Done Indicator
- ◆ Fully Assembled and Tested

## Ordering Information

PART	TYPE
MAX8685CEVKIT+	EV Kit

+ Denotes lead-free and RoHS-compliant.

## Component List

DESIGNATION	QTY	DESCRIPTION
C1	1	1 $\mu$ F $\pm$ 10%, 6.3V X5R ceramic capacitor (0402) Murata GRM155R60J105K or equivalent
C2	1	10 $\mu$ F $\pm$ 10%, 16V X5R ceramic capacitor (0805) Taiyo Yuden EMK212BJ106K or equivalent
C3	1	35 $\mu$ F $\pm$ 20%, 330V photoflash aluminum electrolytic capacitor Rubycon 330FW35M
C4	0	Not installed
C5	1	0.022 $\mu$ F $\pm$ 10%, X7R 630V ceramic capacitor (1206) Taiyo Yuden SMK316BJ223K

DESIGNATION	QTY	DESCRIPTION
C6	1	3300pF $\pm$ 10%, 50V X5R ceramic capacitor (0402) Murata GRM155R71H332K or equivalent
D1	1	Yellow LED (0603) Panasonic LNJ412K84RA
D2	1	Dual-series diode (SOT23) Central Semiconductor CMPD2005S or equivalent
FT1	1	Trim xenon 1.5 FTA PerkinElmer DTS TrimXel.5FTA
JU1	1	2-pin header 1 x 36-pin header, 0.1in centers (comes in 1 x 36-pin strips, cut to fit) Sullins PEC36SAAN Digi-Key S1012E-36-ND

Evaluates: MAX8685C/MAX8685D

# MAX8685C Evaluation Kit

## Component List (continued)

DESIGNATION	QTY	DESCRIPTION
Q1	1	Insulated gate bipolar transistor (IGBT) Renesas CY25CAH-8F Renesas RJP4002ANS
R1, R2	2	124k $\Omega$ $\pm$ 1% resistors (1206), lead free
R3	1	1k $\Omega$ $\pm$ 1% resistor (0402), lead free
R4	1	10 $\Omega$ $\pm$ 1% resistor (0402), lead free
R5, R6	2	402 $\Omega$ $\pm$ 1% resistors (0402), lead free
R7A, R7B	2	499k $\Omega$ $\pm$ 1% resistors (1206), lead free
R8-R13	6	24.9k $\Omega$ $\pm$ 1% resistors (1206), lead free
SW1, SW2	2	250VAC, 2A SPDT switches (ON-OFF-ON) Mountain Switch 108-1MS1T6B1M2QE-EVX or equivalent

DESIGNATION	QTY	DESCRIPTION
SW3	1	Momentary pushbutton N.O. switch Panasonic EVQ-PHP03T
T1	1	Transformer TDK LDT565630T-011 Tokyo Coil TTRN-SU20S-00 1T
T2	1	Transformer Tokyo Coil TS-F45B-1
U1	1	MAX8685CETA+ (8-pin TDFN-EP, 2mm x 3mm)
—	1	PCB: MAX8685C Evaluation Kit

## Component Suppliers

SUPPLIER	PHONE	WEBSITE
Central Semiconductor	631-435-1110	www.centrasemi.com
Panasonic Corp.	714-373-7939	www.panasonic.com
PerkinElmer, Inc.	781-663-6900	www.perkinelmer.com
Philips/nxp Semiconductor	408-474-8142	www.semiconductors.philips.com
Renesas Technology Corp.	408-382-7500	www.renesas.com
Rubycon Corp.	408-467-3864	www.rubycon.com
Taiyo Yuden	408-573-4150	www.t-yuden.com
TDK Corp.	847-803-6100	www.component.tdk.com
Tokyo Coil Engineering	81-426-56-6262	www.tokyo-coil.co.jp

**Note:** Indicate that you are using the MAX8685C when contacting these component suppliers.

# MAX8685C Evaluation Kit

Evaluates: MAX8685C/MAX8685D

## Quick Start

### Recommended Equipment

- 2.5V to 5.5V power supply capable of delivering 2A
- Voltmeter capable of measuring at least 300V

### Procedure

The MAX8685C EV kit is fully assembled and tested. Follow the steps below to verify board operation.

**Caution: Lethal voltages are present in this circuit.**

- 1) Before connecting the EV kit, verify that the output capacitor is discharged. To discharge the output capacitor, set SW2 to the discharge position (Figure 1). Wait at least 30s before proceeding.
- 2) Verify that SW1 is in the disable position and that a shunt is shorting JU1.
- 3) Turn on the power supply and preset to the desired voltage between 2.5V and 5.5V.
- 4) Turn off the power supply. **Do not turn on the power supply until all connections are completed.**
- 5) Connect the positive terminal of the power supply to the EV kit pad labeled BATT.
- 6) Connect the negative terminal of the power supply to the EV kit pad labeled PGND.
- 7) Connect the positive terminal of the voltmeter to OUT.
- 8) Connect the negative terminal of the voltmeter to PGND.
- 9) Turn on the power supply.
- 10) Set SW2 to the open position (Figure 1) to disconnect the discharge resistors.
- 11) Set SW1 to the enable position to turn on the IC.
- 12) After a few seconds (depending on the supply voltage), verify that the LED lights up, indicating the charge is complete.
- 13) Verify that the voltmeter reads 300V.
- 14) Push SW3 and verify that the flash tube has flashed.

When evaluation of the MAX8685C EV kit is completed, use the following steps to power down the EV kit:

- 1) Set SW1 to the upward position (Figure 1) to disable the IC.
- 2) Turn off the power supply.
- 3) Set SW2 to the discharge position (Figure 1).
- 4) Wait at least 30s for the output capacitor to discharge.
- 5) Verify that the output voltage has dropped to near zero.
- 6) Disconnect the power supply and voltmeter from the EV kit.

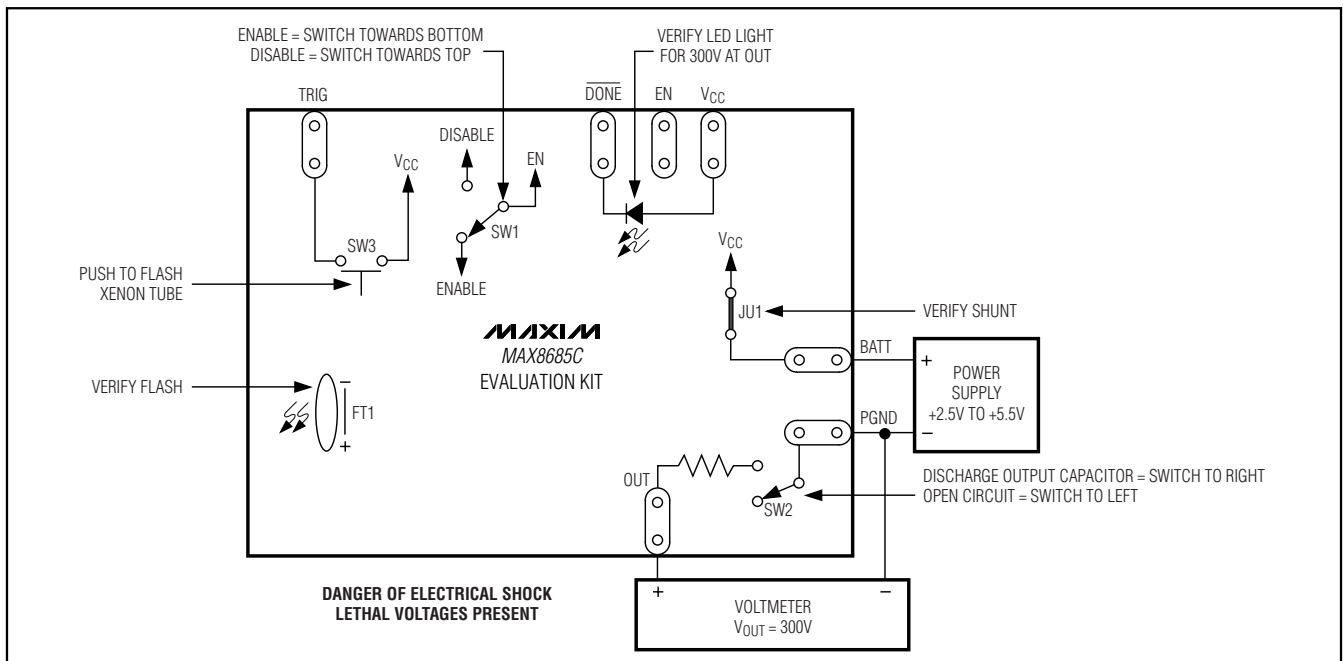

Figure 1. Test Procedure Setup for MAX8685C EV Kit

# MAX8685C Evaluation Kit

Table 1. Jumper Settings

JUMPER	FUNCTION
JU1	Shorts V <sub>CC</sub> (IC supply for MAX8685C EV kit) to BATT (transformer primary supply). Short JU1 for single-supply 2.5V to 5.5V operation. Open JU1 for separate V <sub>CC</sub> (2.5V to 5.5V) and BATT (1.5V to 10V) supplies.

## Detailed Description

### V<sub>CC</sub> and BATT Supplies

For single-supply operation, install a shunt for JU1 and connect the 2.5V to 5.5V supply to the pad on the EV kit labeled BATT. When using separate supplies to power the IC and the transformer primary, remove the shunt from JU1. Connect the 2.5V to 5.5V power supply to the EV kit pad labeled V<sub>CC</sub> and connect the 1.5V to 10V transformer power supply to the EV kit pad labeled BATT.

### Adjusting the Output Voltage

The output voltage is set by the ratio of a resistor voltage-divider. Choose R3 less than 2kΩ. The EV kit comes with a 1kΩ resistor installed. **Larger resistor values, combined with parasitic capacitance at FB, can slow the rise time of the FB voltage during each cycle. This may prevent the MAX8685C from detecting when the output voltage has reached the desired level.**

The value for upper resistors R1 and R2 (R1 = R2) is calculated by:

$$R1 + R2 = R3 \times \left( \frac{V_{OUT}}{V_{FB}} - 1 \right)$$

where V<sub>FB</sub> is 1.25V.

Make sure the voltage rating of the resistors exceeds the desired output voltage. Two resistors in series are used for the upper resistor to meet the resistor voltage rating. Verify that the voltage rating of the output capacitor and diode(s) exceed the desired output voltage. Also, make sure the transformer turns ratio is acceptable for the output voltage selected. Refer to the MAX8685A–MAX8685F IC data sheet for more information on selecting the transformer turns ratio. The EV kit comes with the TDK LDT565630T-011 transformer installed, but the footprint also accommodates the Tokyo Coil TTRN-SU20S-00 1T.

### Flashing the Xenon Tube

The MAX8685C provides an integrated insulated gate bipolar transistor (IGBT) driver for discharging the photoflash capacitor through a xenon flash tube.

To turn on the IGBT gate, push down on SW3. Releasing SW3 drives TRIG low and turns off the IGBT gate. The IGBT driver circuitry remains active when EN is pulled low and V<sub>CC</sub> is valid. This allows a reduction in battery-power consumption while the photoflash capacitor is being discharged through the xenon flash tube. However, EN may be left high so that multiple flashes at maximum intensity can occur in rapid succession if needed.

If the MAX8685C EV kit is to be used with another xenon flash tube, ensure proper polarities are observed upon installation (Figure 2).

### DONE Output

An LED and resistor are connected between V<sub>CC</sub> and DONE to indicate when the charge cycle is complete. To use DONE as a logic-level output instead of driving an LED, remove resistor R5 and D1 from the EV kit and install a pullup resistor in R5 and a 0Ω resistor for D1. If the flash tube has been fired, or after 16s of automatic refresh mode, DONE does not assert a second time. DONE remains asserted until SW1 is toggled. **DONE is not a safety indicator.**

### Discharge Circuit

Resistors R8–R13 and switch SW2 are used to discharge the output capacitor. After power is shut down, set SW2 to the discharge position to discharge the output capacitor.

### Evaluating the MAX8685D

To evaluate the MAX8685D on the MAX8685C EV kit, replace the installed IC with a MAX8685D. Note that the default current limit increases to 1.6A when the MAX8685D is installed.

# MAX8685C Evaluation Kit

Evaluates: MAX8685C/MAX8685D

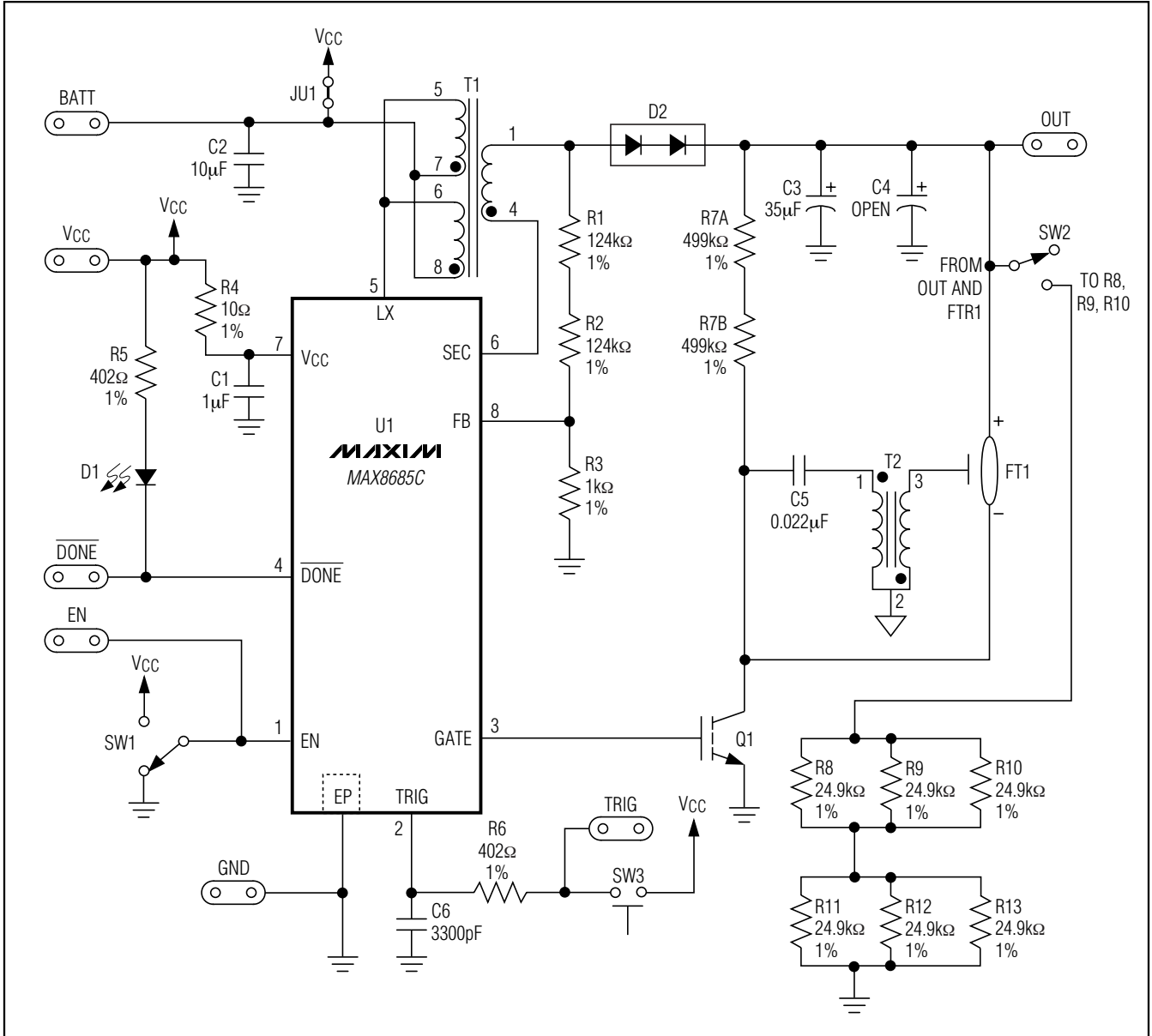

Figure 2. MAX8685C EV Kit Schematic for Single-Supply Operation

# MAX8685C Evaluation Kit

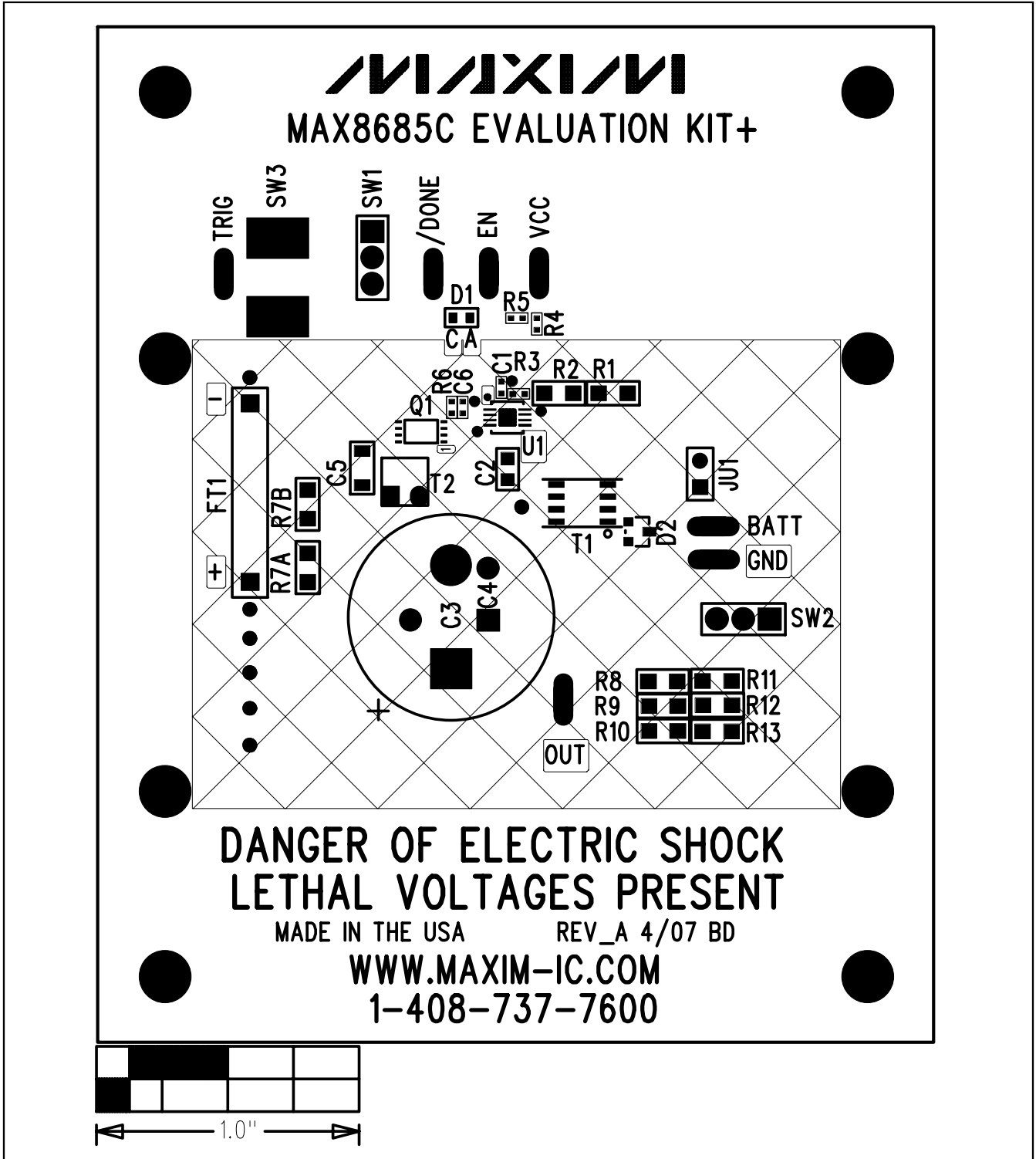

Figure 3. MAX8685C EV Kit Component Placement Guide—Component Side

# MAX8685C Evaluation Kit

Evaluates: MAX8685C/MAX8685D

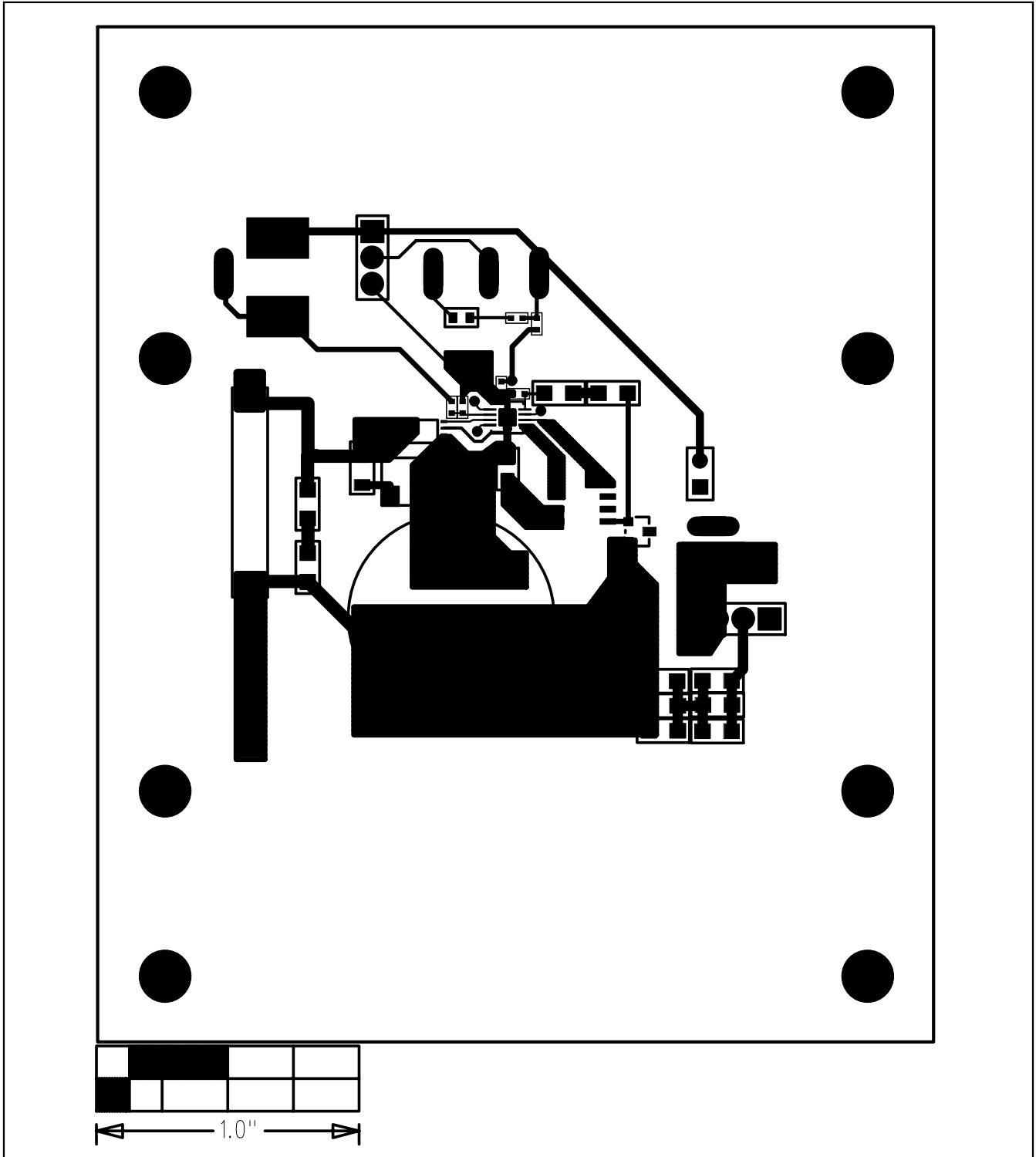

Figure 4. MAX8685C EV Kit PCB Layout—Component Side

# MAX8685C Evaluation Kit

Evaluates: MAX8685C/MAX8685D

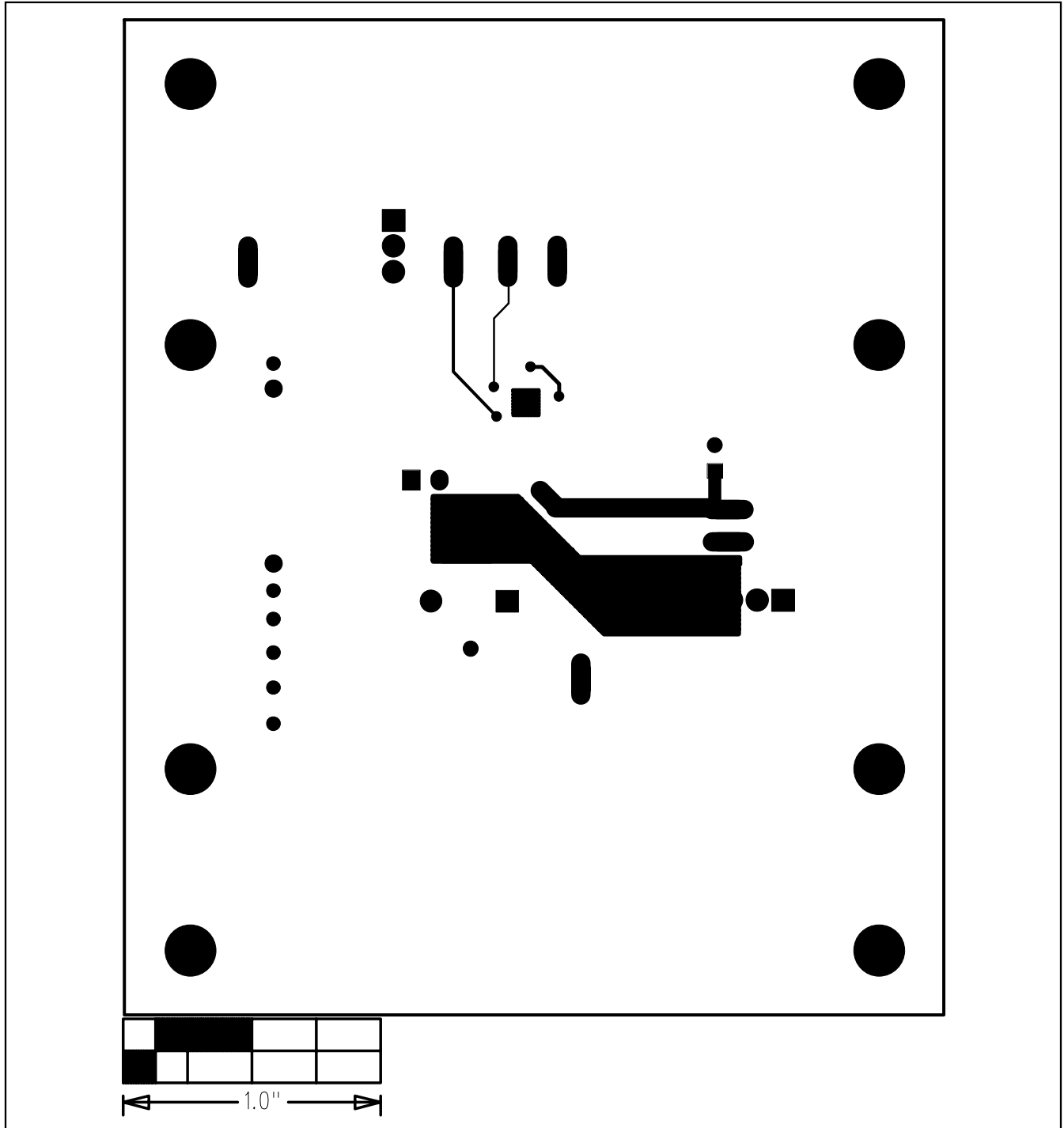

Figure 5. MAX8685C EV Kit PCB Layout—Solder Side

Maxim cannot assume responsibility for use of any circuitry other than circuitry entirely embodied in a Maxim product. No circuit patent licenses are implied. Maxim reserves the right to change the circuitry and specifications without notice at any time.

8 \_\_\_\_\_ Maxim Integrated Products, 120 San Gabriel Drive, Sunnyvale, CA 94086 408-737-7600

© 2007 Maxim Integrated Products

MAXIM is a registered trademark of Maxim Integrated Products, Inc.