



MAX7036 Evaluation Kit

General Description

The MAX7036 evaluation kit (EV kit) provides a proven design to evaluate the MAX7036 ASK receiver in a TQFN package with an exposed pad. The EV kit enables testing of the device's RF performance and requires no additional support circuitry. The RF input uses an SMA connector for convenient connection to test equipment.

The MAX7036 EV kit is available in two versions, 315MHz (MAX7036EVKIT315+) and 433.92MHz (MAX7036EVKIT433+). The passive components are optimized for these frequencies. The EV kit PCBs come with a MAX7036GTP+ installed on both EV kit versions.

Features

- ◆ Lead(Pb)-Free and RoHS Compliant
- ◆ Proven PCB Layout
- ◆ Proven Components List
- ◆ Available in 315MHz and 433.92MHz Versions
- ◆ Fully Assembled and Tested

Ordering Information

PART	TYPE
MAX7036EVKIT-315+	EV Kit
MAX7036EVKIT-433+	EV Kit

+Denotes lead(Pb)-free and RoHS compliant.

Component List

DESIGNATION	QTY	DESCRIPTION
C1, C9, C13, C20	4	0.1 μ F \pm 10%, 16V X7R ceramic capacitors (0603) Murata GRM188R71C104K
C2, C17	0	Not installed, capacitors (0603)
C3, C16	2	315MHz: 4.7pF \pm 5%, 50V C0G ceramic capacitors (0603) Murata GRM1885C1H4R7C 433.92MHz: 10pF \pm 5%, 50V C0G ceramic capacitors (0603) Murata GRM1885C1H100J
C4	1	1 μ F \pm 10%, 6.3V X5R ceramic capacitor (0603) Murata GRM188R60J105K
C5	1	180pF \pm 10%, 50V C0G ceramic capacitor (0603) Murata GRM1885C1H181J
C6	1	22pF \pm 5%, 50V C0G ceramic capacitor (0603) Murata GRM1885C1H220J
C7, C8, C11, C14, C15	5	100pF \pm 5%, 50V C0G ceramic capacitors (0603) Murata GRM1885C1H101J
C10, C12	2	0.01 μ F \pm 10%, 25V X7R ceramic capacitors (0603) Murata GRM188R71E103K
C18	1	390pF \pm 5%, 50V C0G ceramic capacitor (0603) Murata GRM1885C1H391J

DESIGNATION	QTY	DESCRIPTION
C19	1	315MHz: 4.7pF \pm 5%, 50V C0G ceramic capacitor (0603) Murata GRM1885C1H4R7C 433.92MHz: 2.7pF \pm 0.1pF, 50V C0G ceramic capacitor (0603) Murata GRM1885C1H2R7B
C21	1	10pF \pm 5%, 50V C0G ceramic capacitor (0603) Murata GRM1885C1H100J
C22	1	10 μ F \pm 20%, 6.3V X5R ceramic capacitor (0603) Murata GRM188R60J106M
C23	1	220pF \pm 10%, 50V X7R ceramic capacitor (0603) Murata GRM188R71H221K
JU1, JU3	2	2-pin headers
JU2, JU4	2	3-pin headers
L1	1	315MHz: 100nH \pm 2% inductor (0603) Murata LQW18ANR10G00 433.92MHz: 47nH \pm 2% inductor (0603) Murata LQW18AN47NG00
L2	1	315MHz: 27nH \pm 2% inductor (0603) Murata LQW18AN27NG00 433.92MHz: 15nH \pm 2% inductor (0603) Murata LQW18AN15NG00

Evaluates: MAX7036

MAX7036 Evaluation Kit

Component List (continued)

DESIGNATION	QTY	DESCRIPTION
P1	1	SMA end-launch jack receptacle
P2	1	SMA female vertical-mount PCB connector
R1	1	22k Ω \pm 5% resistor (0603)
R2	0	Not installed, resistor (0603)
TP1–TP4	4	Miniature red test points
U1	1	ASK receiver (20 TQFN-EP*) Maxim MAX7036GTP+

*EP = Exposed pad.

DESIGNATION	QTY	DESCRIPTION
Y1	1	315MHz: 9.8375MHz crystal (AT-51CD2) NDK EXS00A-AT00733
		433.92MHz: 13.55375MHz crystal (AT-51CD2) NDK EXS00A-AT00732
—	3	Shunts
—	1	PCB: MAX7036 EVALUATION KIT+

Component Suppliers

SUPPLIER	PHONE	WEBSITE
Murata Electronics North America, Inc.	770-436-1300	www.murata-northamerica.com
NDK America (Nihon Dempa Kogyo Co., Ltd.)	815-544-7900	www.ndk.com/en

Note: Indicate that you are using the MAX7036 when contacting these component suppliers.

Quick Start

Required Equipment

- MAX7036 EV kit
- 3.3V, 20mA DC power supply
- RF generator capable of delivering -120dBm to 0dBm output power at the operating frequency, in addition to amplitude modulation (AM) or pulse modulation (e.g., Agilent E4420B or equivalent)
- Oscilloscope
- Optional ammeter for measuring supply current

Procedure

The MAX7036 EV kit is fully assembled and tested. Follow the steps below to verify board operation.

Caution: Do not turn on the DC power supply or RF signal generator until all connections are completed.

- 1) Verify that the jumpers are in their default position, as shown in Table 1.
- 2) Connect a 3.3V DC power supply (through an ammeter, if desired) to the VDD and GND pads on the EV kit. Do not turn on the supply.
- 3) Connect the RF signal generator to the P2 SMA connector. Do not turn on the generator output. Set the generator for an output carrier frequency of 315MHz (or 433.92MHz) at a power level of -100dBm. Set the modulation of the generator to provide 100% AM (or pulse modulation), with a 4kHz square wave.

- 4) Connect the oscilloscope to test point TP2 (DATAOUT).
- 5) Turn on the DC power supply. The supply current should be between 5mA and 6mA.
- 6) Activate the RF generator's output without modulation. Set the RF generator to -100dBm. Enable AM square-wave (or pulse) modulation on the RF generator and set the scope's coupling to DC. The scope now displays a 4kHz square wave at TP2.

Additional Evaluation

- 1) With the modulation still set to AM (or pulse), observe the effect of reducing the RF generator's amplitude at TP2 (DATAOUT). The error rate in this sliced digital signal increases with reduced RF signal level. The sensitivity is usually defined as the point at which the error in interpreting the data increases beyond a set limit, as defined by a bit-error rate (BER) test.
- 2) Connect the oscilloscope to test point TP1, set the scope's coupling to AC, and adjust the voltage sensitivity. The scope now displays a lowpass-filtered square wave (filtered analog baseband data).
- 3) Set the scope's coupling to DC, adjust the voltage sensitivity, and turn off the modulation from the RF generator. The scope should display a DC voltage that varies from approximately 1.35V to 2.2V as the RF generator amplitude is changed from -115dBm to 0dBm. **Note:** At an input amplitude of

MAX7036 Evaluation Kit

Table 1. Jumper Table (JU1–JU4)

JUMPER	SHUNT POSITION	DESCRIPTION
JU1	Open	Disconnects AVDD and DVDD from VDD. Apply up to 5V on the VDD pad. An internal regulator provides power to AVDD and DVDD.
	Closed*	Connects AVDD and DVDD to VDD. When connected, do not exceed 3.3V on the VDD pad.
JU2	1-2*	Connects ENABLE to VDD (normal operation)
	2-3	Connects ENABLE to GND (shutdown)
JU3	Open*	Always keep open. Provides a test point for the IF signal.
JU4	1-2	Connects PDOUT to DSN node for faster data detection (if populated)
	2-3*	Connects PDOUT to GND through R2 and C17 (if populated)

* Default position.

approximately -60dBm, this DC voltage drops suddenly to about 1.76V and then rises again with increasing input amplitude. This is normal; the AGC is turning on the LNA gain-reduction resistor.

- 4) Capacitors C5 and C18 are used to set the corner frequency of the 2nd-order lowpass Sallen-Key data filter. The current values were selected for bit rates up to 4kbps Manchester. Adjusting these values accommodates different data rates (refer to the MAX7036 IC data sheet for more details).

Layout Issues

A properly designed PCB is essential for any RF/microwave circuit. Keep high-frequency input and output lines as short as possible to minimize losses and radiation. At high frequencies, trace lengths that are on the order of $\lambda/10$ or longer can act as antennas.

Both parasitic inductance and capacitance are influential on circuit layouts and are best avoided by using short trace lengths. Generally, a 10-mil wide PCB trace, 0.0625in above a ground plane, with FR4 dielectric has about 19nH/in of inductance and about 1pF/in of capacitance. In the LNA/mixer circuit, where the inductor is on the order of 20nH and a capacitor is on the order of 3pF, the proximity of the circuit to the MAX7036 has a strong influence on the effective component values.

To reduce the parasitic inductance, use a solid ground or power plane below the signal traces. Also, use low-inductance connections to ground on all GND pins, and place decoupling capacitors close to all VDD connections.

Table 2. Test Points

TEST POINT	DESCRIPTION
TP1	Noninverting op-amp input
TP2	DATAOUT output
TP3	PDOUT output
TP4	GND

Detailed Description of Hardware

The MAX7036 EV kit provides a proven layout for the MAX7036. On-board test points are included to monitor various signals (Table 2).

Power Supply

The MAX7036 can operate from 3.3V or 5V supplies. For 5V operation, remove the shunt from JU1 before connecting the supply to VDD. AVDD and DVDD operate from an internal linear regulator when VDD = 5V. For 3.3V operation, connect the shunt on JU1.

IF Signal

Jumper JU3 with one side grounded is provided to monitor the IF signal. A shunt cannot be used at JU3.

External Frequency Input

For applications where an external frequency is desired over the crystal frequency, it is possible to remove the crystal and apply an external frequency through P1. Capacitor C2 is necessary (use a 0.01 μ F capacitor).

MAX7036 Evaluation Kit

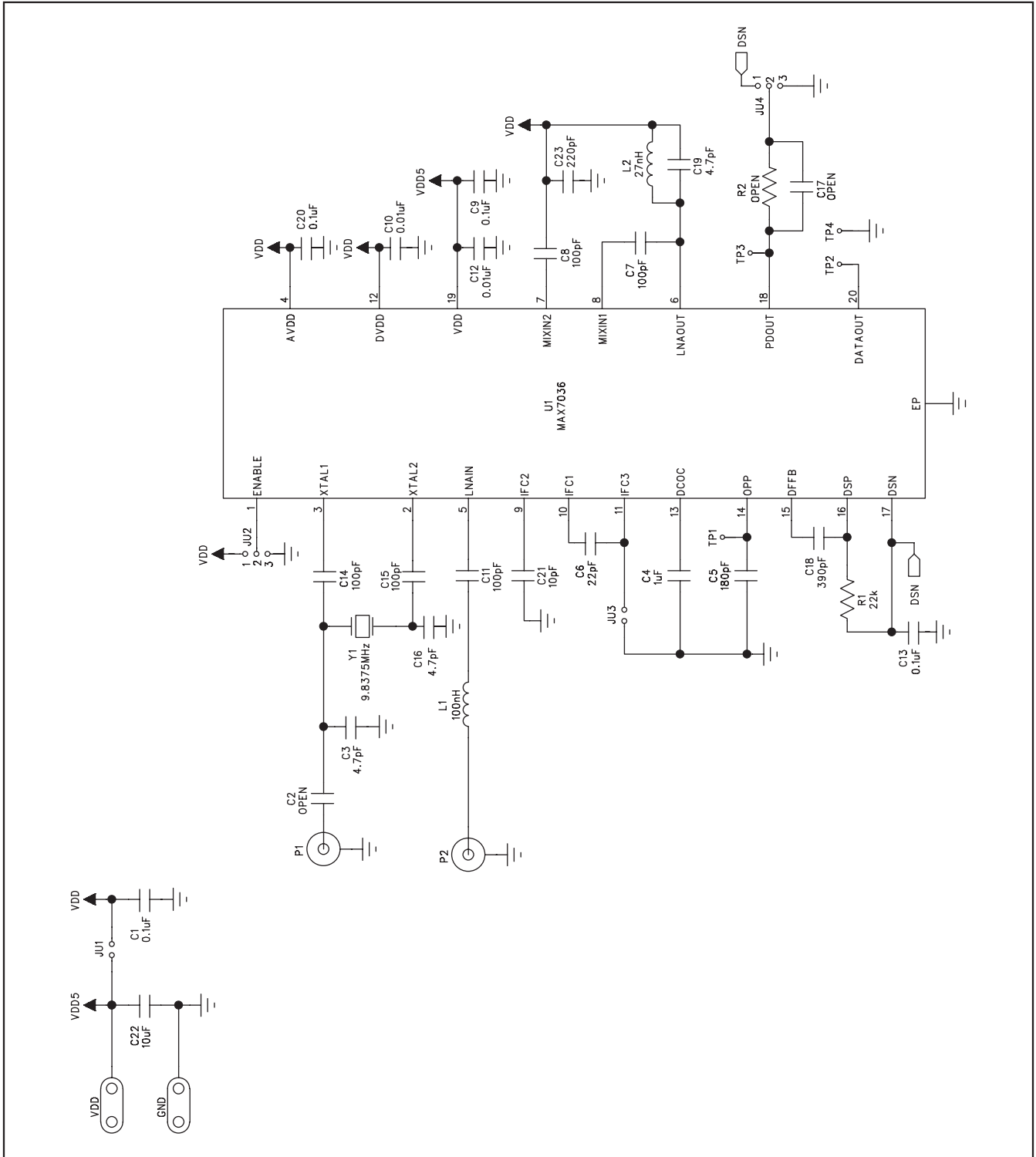

Figure 1. MAX7036EVKIT315+ EV Kit Schematic

MAX7036 Evaluation Kit

Evaluates: MAX7036

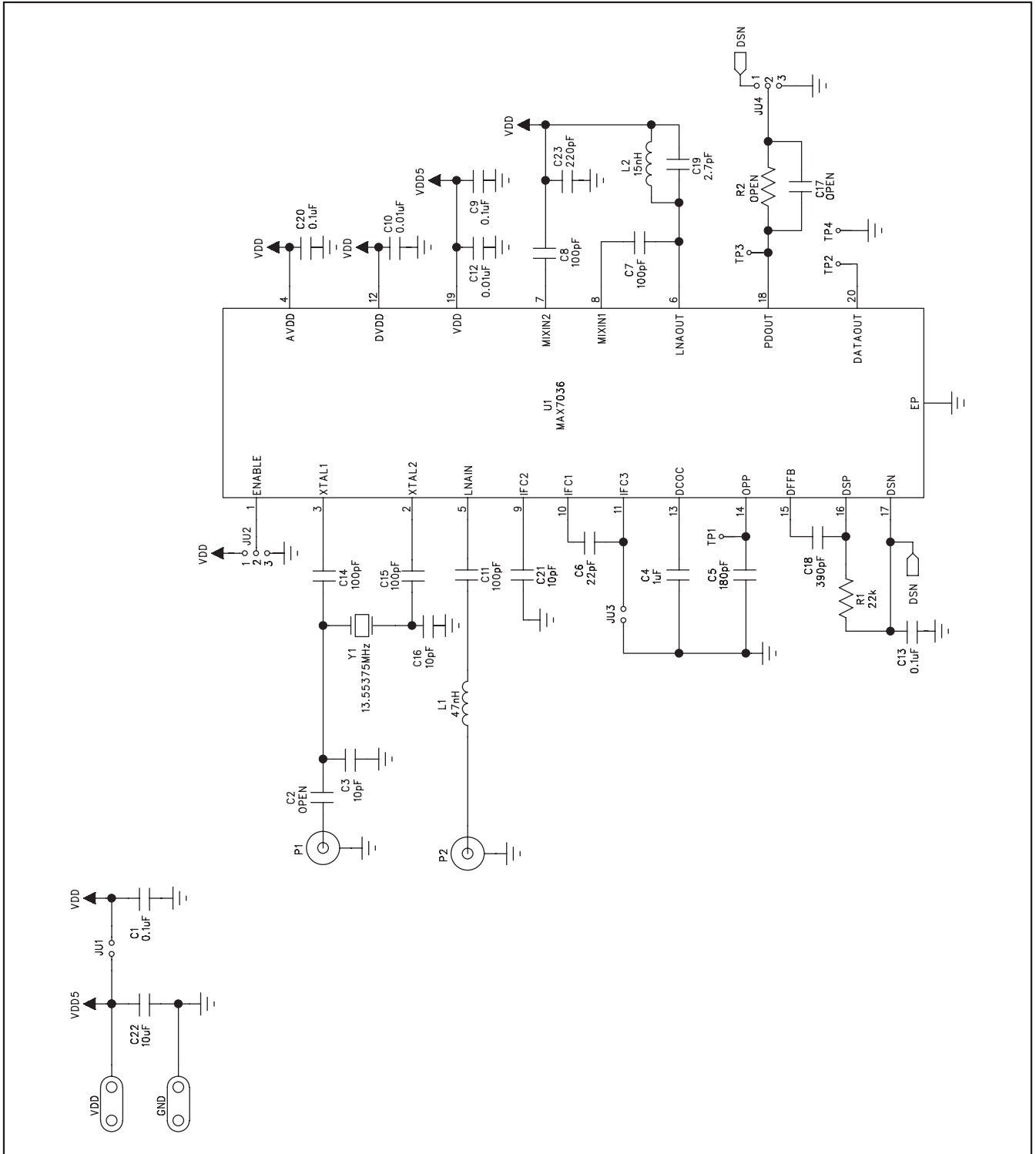

Figure 2. MAX7036EVKIT433+ EV Kit Schematic

MAX7036 Evaluation Kit

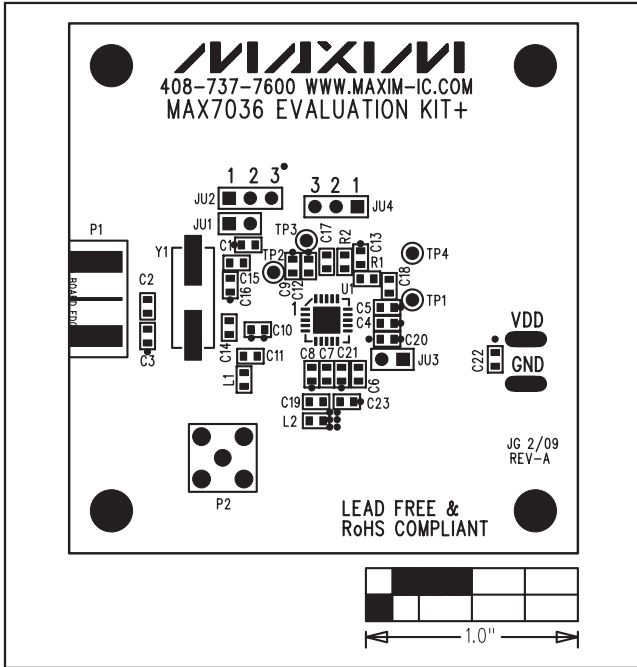

Figure 3. MAX7036 EV Kit Component Placement Guide—Component Side

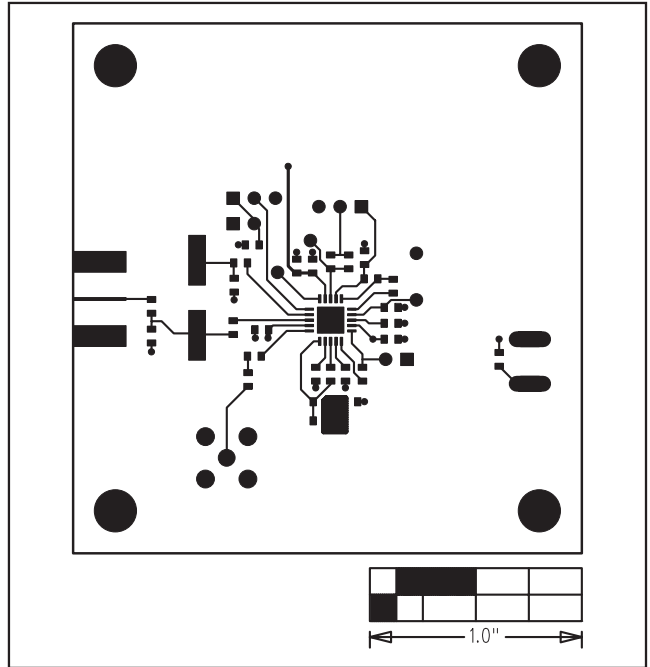

Figure 4. MAX7036 EV Kit PCB Layout—Component Side

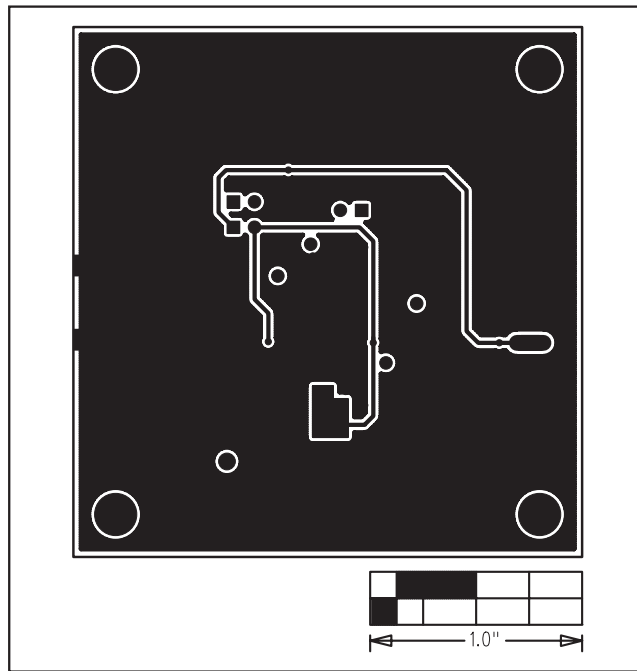

Figure 5. MAX7036 EV Kit PCB Layout—Solder Side

Maxim cannot assume responsibility for use of any circuitry other than circuitry entirely embodied in a Maxim product. No circuit patent licenses are implied. Maxim reserves the right to change the circuitry and specifications without notice at any time.

6 **Maxim Integrated Products, 120 San Gabriel Drive, Sunnyvale, CA 94086 408-737-7600**