



MAX6966 Evaluation Kit/Evaluation System

General Description

The MAX6966 evaluation (EV) kit is an assembled and tested PCB that demonstrates the capabilities of the MAX6966 constant-current LED driver and port-expander I/Os. The EV kit includes three RGB LEDs and one white LED that can be controlled simultaneously by the MAX6966. The EV kit also includes PC software that allows a user to evaluate the features of the MAX6966 using a graphical user interface (GUI).

The MAX6966 evaluation system (EV system) includes a MAX6966 EV kit and a Maxim command module (CMAHQUSB).

The CMAHQUSB board connects to a PC's USB port and allows the transfer of SPI™ commands to the MAX6966 EV kit.

SPI is a trademark of Motorola, Inc.

Windows is a registered trademark of Microsoft Corp.

Features

- ◆ Proven PCB Layout
- ◆ Windows® 98/2000/XP-Compatible Evaluation Software
- ◆ Three RGB LEDs and One White LED
- ◆ Header for Access to SPI Interface Lines
- ◆ Fully Assembled and Tested

Ordering Information

PART	TYPE	INTERFACE
MAX6966EVKIT	EV Kit	User-supplied SPI interface
MAX6966EVCMAHQ	EV System	CMAHQUSB interface board

Note: The MAX6966 EV kit software is included with the MAX6966 EV kit, but is designed for use with the complete EV system. The EV system includes both the Maxim CMAHQUSB and the EV kit. If Windows software will not be used, the EV kit board can be purchased without the CMAHQUSB.

Component List

MAX6966 EV System

PART	QTY	DESCRIPTION
MAX6966EVKIT	1	MAX6966 EV kit
CMAHQUSB	1	Maxim command module

MAX6966 EV Kit

DESIGNATION	QTY	DESCRIPTION
C1	1	0.1µF ±10%, 6.3V X5R capacitor (0402) TDK C1005X5R0J104K
C2	1	10µF ±10%, 6.3V X5R capacitor (0603) TDK C1608X5R0J106K
D1, D2, D3	3	RGB LEDs Stanley FRGB1304B Lumex SML-LX2832SISUGSBC
D4	1	White LED Osram LW T67C-S2U1-5K8L
J1	1	2 x 20 right-angle receptacle

MAX6966 EV Kit (continued)

DESIGNATION	QTY	DESCRIPTION
J2	1	2 x 10-pin header
JU1	1	2-pin header
JU2	1	3-pin header
JU3	0	Not installed (5-pin header)
R1	1	4.7kΩ ±5% resistor (0402)
R2-R11	0	Not installed, resistors (0402)
SW1	0	Not installed (momentary switch) Omron B3F-1000
U1	1	LED driver (16 TQFN) Maxim MAX6966ATE
—	12	Shunts
—	1	MAX6966 evaluation kit software, CD-ROM*
—	1	PCB: MAX6966 Evaluation Kit

*The latest version of the EV kit software can be downloaded at www.maxim-ic.com.

Evaluate: MAX6966/MAX6967

MAX6966 Evaluation Kit/Evaluation System

Component Suppliers

SUPPLIER	PHONE	WEBSITE
Stanley Electric	800-533-5231	www.stanley-components.com
TDK Corp.	847-803-6100	www.component.tdk.com

Note: Indicate that you are using the MAX6966 or MAX6967 when contacting these component suppliers.

MAX6966 EV Kit Files

INSTALL.EXE	Installs the EV kit files on your computer
MAX6966.EXE	Executes the application program
UNINST.INI	Uninstalls the EV kit software
Ftd2xx.INF	USB device driver file
Troubleshooting_USB.PDF	Opens the USB Troubleshooting Guide

Quick Start

Recommended Equipment

Before beginning, the following equipment is needed:

- The Maxim MAX6966EVCMAXQU evaluation system
MAX6966EVKIT
Maxim command module (CMAXQUSB)
USB cable (included with CMAXQUSB)
- One power supply
5.5V or higher (up to 7.0V) at 300mA
- A user-supplied Windows 98/2000/XP PC with an unused USB port

Note: In the following sections, software-related items are identified by bolding. Text in **bold** refers to items directly from the EV kit software. Text in **bold and underlined** refers to items from the Windows operating system.

Procedure

The MAX6966 EV kit is fully assembled and tested. Follow the steps below to verify board operation.

Caution: Do not enable the power supply until all connections are completed.

- 1) Place a shunt on the 3.3V setting of JU1 on the CMAXQUSB.
- 2) Place a shunt on pins 1-2 of JU1 on the MAX6966 EV kit (connects MISO to DOUT/OSC).
- 3) Place a shunt on pins 1-2 of JU2 on the MAX6966 EV kit (3.3V for V+ supplied from CMAXQUSB).
- 4) Connect the MAX6966 EV kit's 40-pin female connector (J1) to the CMAXQUSB's 40-pin male connector (P4).
- 5) Install the MAX6966 EV kit software on your PC by running the INSTALL.EXE program. The files can be

obtained from the Maxim website or the included CD. The program files are copied and icons are created for them in the Windows **Start** menu.

- 6) Connect the USB cable between the PC's USB port and the CMAXQUSB's USB connector (P2). A **New Hardware Found** window pops up. If you don't see this window after 30 seconds, remove the USB cable from the CMAXQUSB and reconnect it again. Administrator privileges are required to install the USB device driver on Windows 2000/XP. Refer to the Troubleshooting_USB.PDF file if problems are experienced during this step.
- 7) Follow the directions of the **Add New Hardware Wizard** to install the USB device driver. Choose the **Search for the best driver for your device** option. Specify the location of the device driver to be **C:\Program Files\MAX6966** (or the directory chosen during installation) using the **Browse** button.
- 8) Connect the 5.5V power supply (up to 7.0V supported) between the MAX6966 EV kit's VLED and GND pads.
- 9) Enable the power supply.
- 10) Start the MAX6966 EV kit software by double-clicking its icon in the **Start** menu. The application window shown in Figure 1 appears, and the software connects to the CMAXQUSB after a few seconds.
- 11) Click on **PWM Output** in the **Port 0 Configuration** group box.
- 12) Check the **Shutdown** checkbox in the **Global PWM Settings** group box to disable the MAX6966's shutdown mode. The white LED (D4) should illuminate on the MAX6966 EV kit.

MAX6966 Evaluation Kit/Evaluation System

Detailed Description of Software

To start the MAX6966 EV kit software, double click the MAX6966 EV kit icon that is created during installation. The graphical user interface shown in Figure 1 appears. Wait approximately two seconds while the MAX6966 EV kit software connects to the CMAXQUSB.

The **Select Port** group box allows the user to select one of the 10 MAX6966 ports to configure. Once a port has been selected, the **Port n Configuration** group box allows the port to be configured as a **Logic-Level Input**, **Logic-Level Output**, or a **PWM Output**.

The **Global PWM Settings** group box includes controls to edit the MAX6966's constant-current LED drivers.

The **Chip Select (CS) Run** option is inaccessible because the CMAXQUSB cannot guarantee timing that would ensure proper operation of this feature.

Note that the **Shutdown** feature is only enabled when the MAX6966's internal oscillator is enabled. To enable the internal oscillator, the DOUT/OUT pin must be set for DOUT and at least one MAX6966 port must be configured for PWM output (at any value except 100% or 0% duty cycle).

The **Advanced I Interface** menu item allows a low-level interface to the CMAXQUSB.

Evaluate: MAX6966/MAX6967

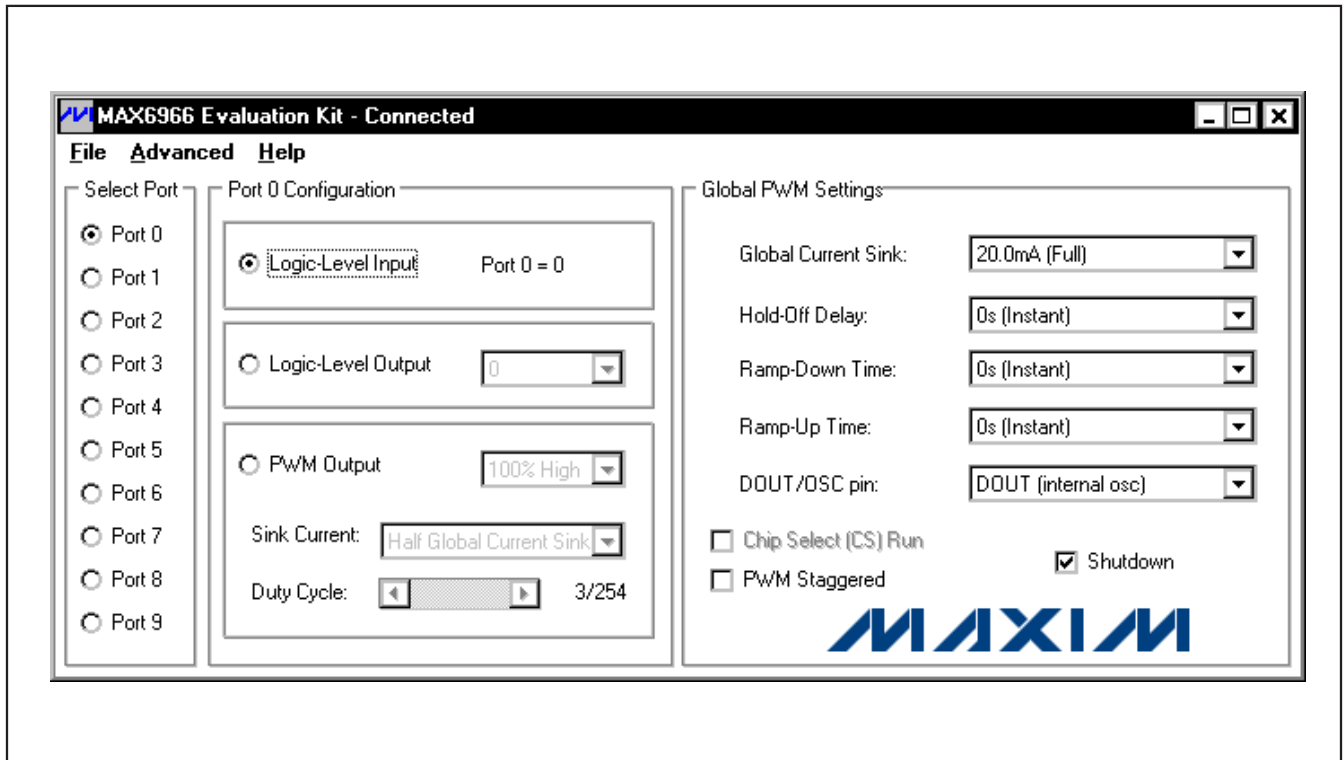

Figure 1. MAX6966 EV Kit Software Screenshot

MAX6966 Evaluation Kit/Evaluation System

Detailed Description of Hardware

MAX6966 EV System

The MAX6966 EV system (MAX6966EVCMAXQU) is a complete 10-port, constant-current LED driver and I/O expander system, consisting of a MAX6966 EV kit and the Maxim command module (CMAXQUSB).

CMAXQUSB

The CMAXQUSB is a Maxim command module that provides an SPI interface bus to demonstrate various Maxim devices. Maxim reserves the right to change the implementation of this module at any time with no advance notice.

MAX6966 EV Kit

The MAX6966 EV kit board provides a proven layout for evaluating the MAX6966 constant-current LED driver and I/O expander IC and can be obtained separately without the CMAXQUSB.

The EV kit includes three RGB LEDs (D1, D2, and D3) and one white LED (D4). These LEDs can be enabled and the current through each LED can be controlled using the MAX6966 EV kit software (see the *Detailed Description of Software* section).

The MAX6966 EV kit also includes PCB landing pads (R2–R11) on the bottom side of the EV kit board that can be used to add pullup resistors on every one of the MAX6966's P0–P9 ports.

Jumper Selection Tables

Tables 1 and 2 explain the functionality of the jumpers on the MAX6966 EV kit.

Table 1. Select IN Source

JUMPER	SHUNT POSITION	DESCRIPTION
JU1	Short*	MISO connected to DOUT/OSC
	Open	MISO not connected to DOUT/OSC

*Default position.

Table 2. Select IN Source

JUMPER	SHUNT POSITION	DESCRIPTION
JU2	1-2*	MAX6966 V+ supplied from CMAXQUSB (3.3V)
	2-3	MAX6966 V+ supplied from V+ pad

*Default position.

MAX6966 Evaluation Kit/Evaluation System

Evaluate: MAX6966/MAX6967

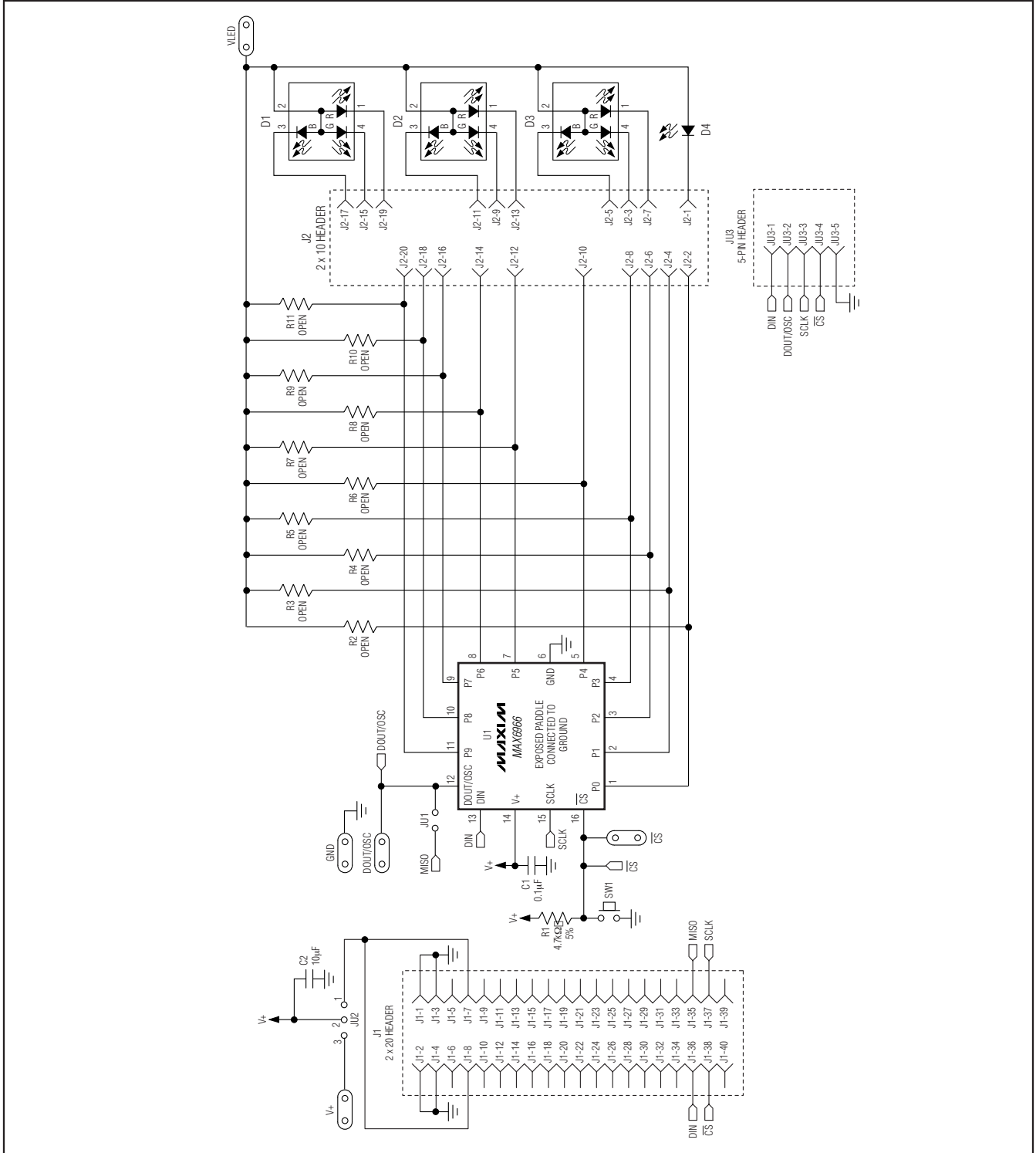

Figure 2. MAX6966 EV Kit Schematic

MAX6966 Evaluation Kit/Evaluation System

Evaluate: MAX6966/MAX6967

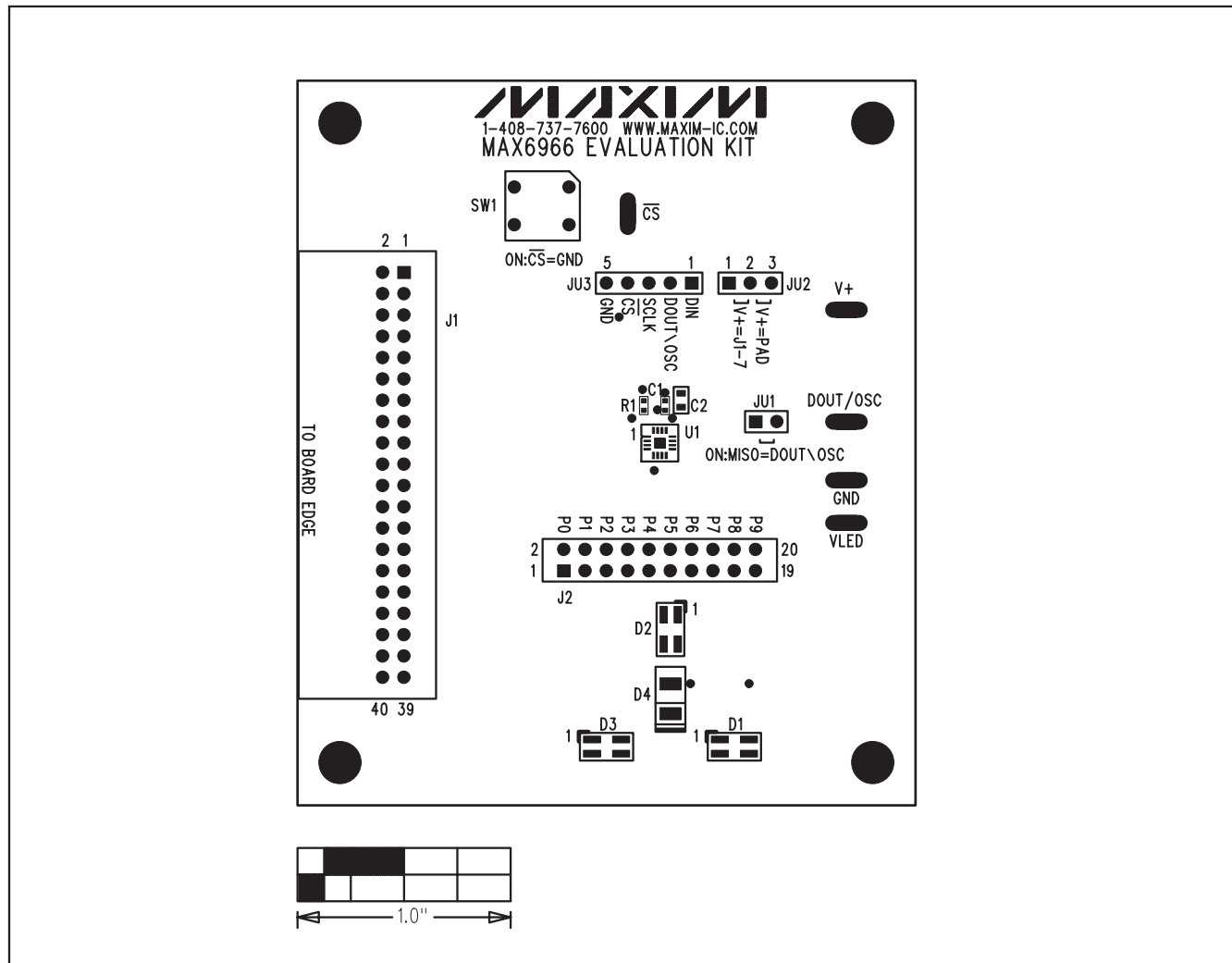

Figure 3. MAX6966 EV Kit Component Placement Guide—Component Side

MAX6966 Evaluation Kit/Evaluation System

Evaluate: MAX6966/MAX6967

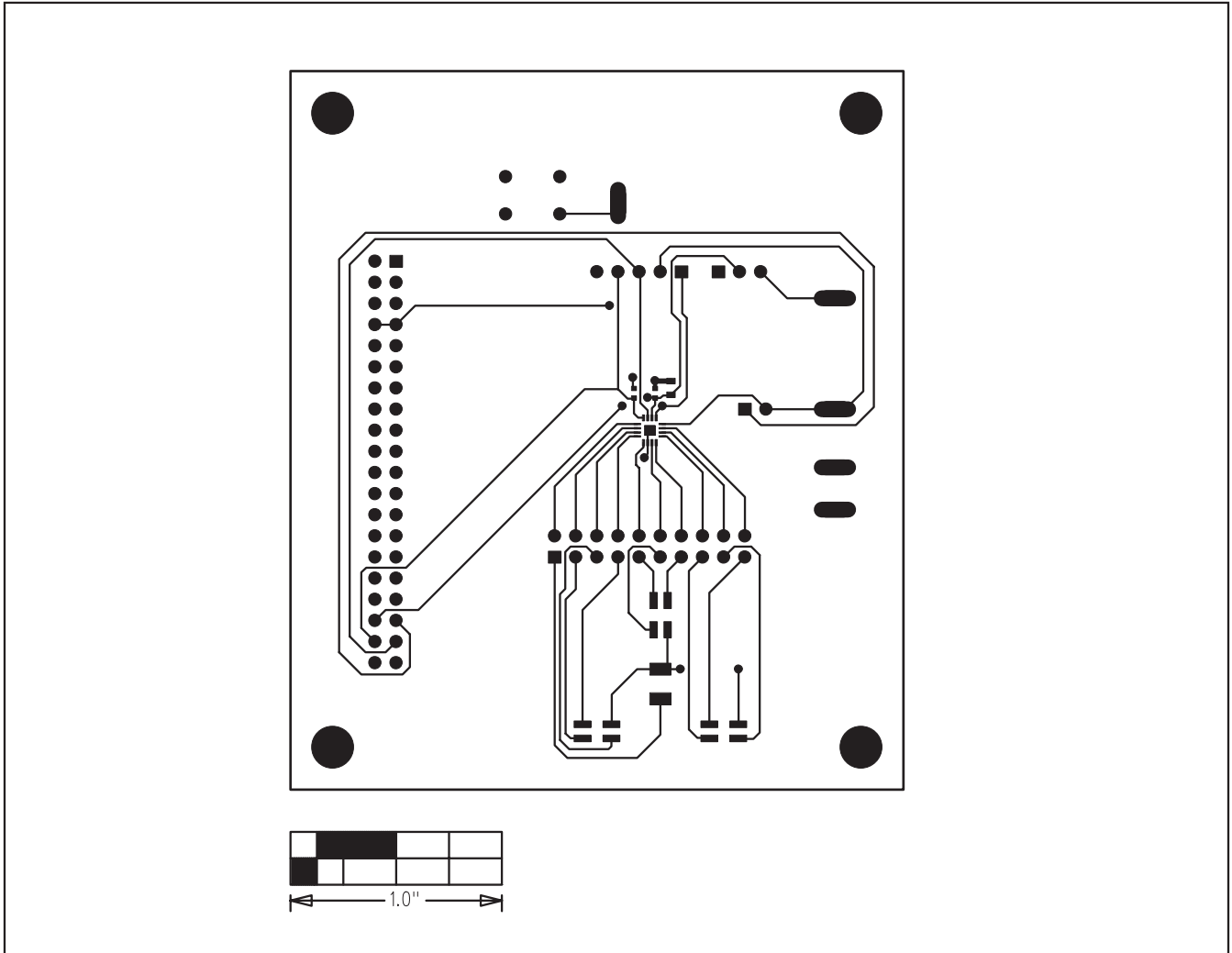

Figure 4. MAX6966 EV Kit PCB Layout—Component Side

MAX6966 Evaluation Kit/Evaluation System

Evaluate: MAX6966/MAX6967

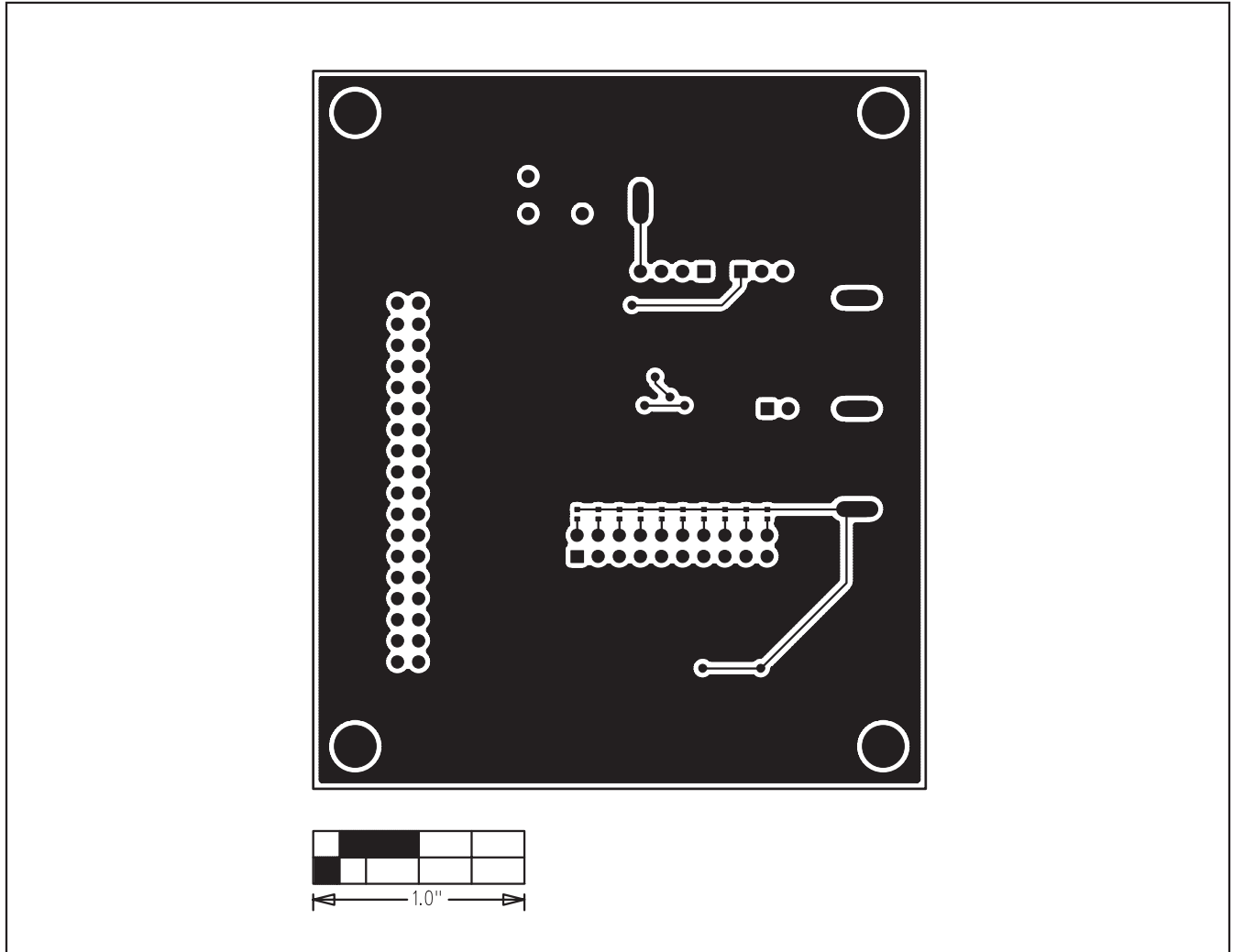

Figure 5. MAX6966 EV Kit PCB Layout—Solder Side

MAX6966 Evaluation Kit/Evaluation System

Evaluate: MAX6966/MAX6967

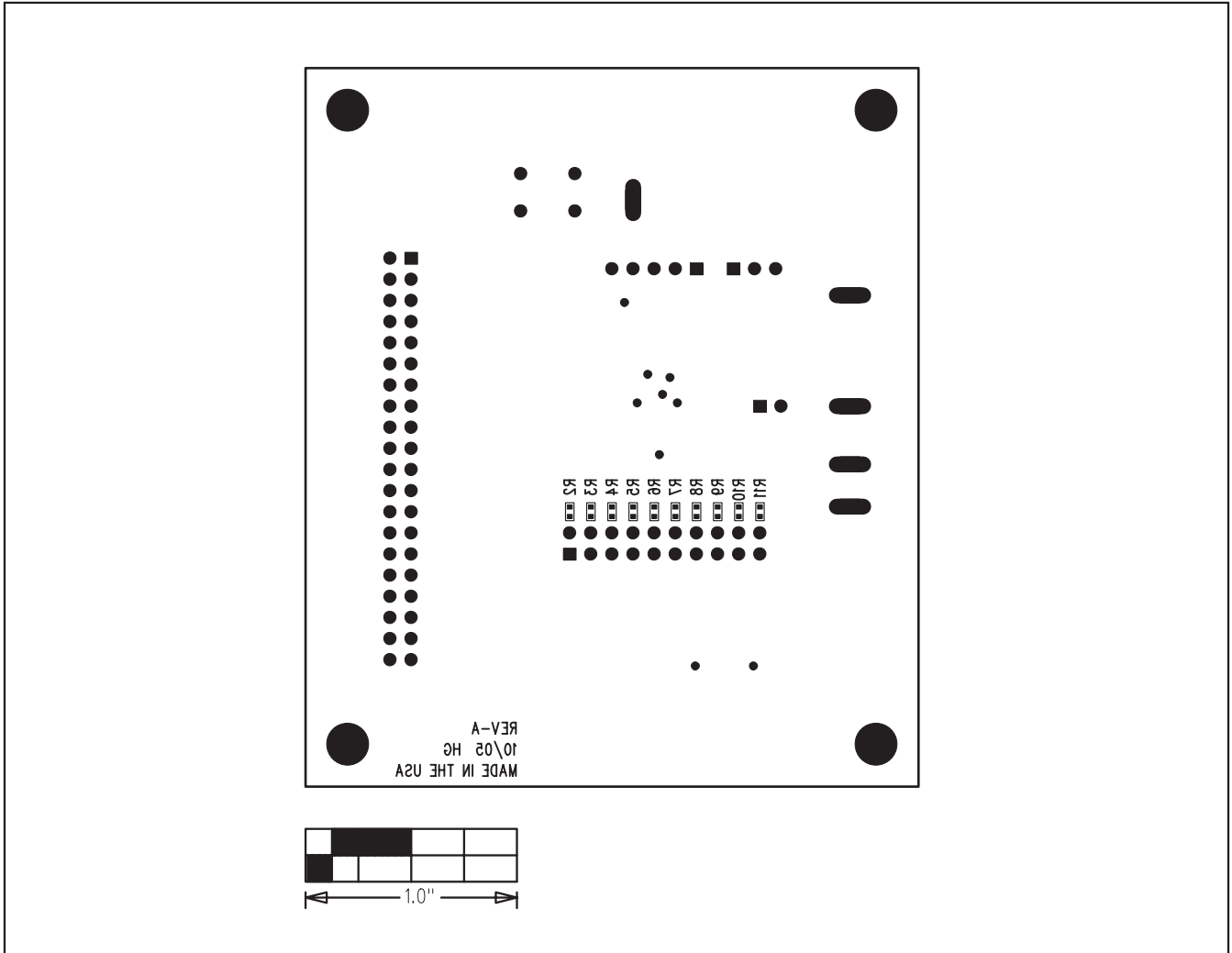

Figure 6. MAX6966 EV Kit Component Placement Guide—Solder Side

MAX6966 Evaluation Kit/Evaluation System

Revision History

REVISION NUMBER	REVISION DATE	REVISION DESCRIPTION	PAGES CHANGED
0	2/06	Initial release	—
1	5/08	Component D4 became obsolete and a replacement part was needed.	1

Maxim cannot assume responsibility for use of any circuitry other than circuitry entirely embodied in a Maxim product. No circuit patent licenses are implied. Maxim reserves the right to change the circuitry and specifications without notice at any time.

10 **Maxim Integrated Products, 120 San Gabriel Drive, Sunnyvale, CA 94086 408-737-7600**