



# MAX5944 Evaluation Kit

**Evaluates: MAX5944**

## General Description

The MAX5944 evaluation kit (EV kit) circuit demonstrates the multiple functions of the MAX5944 IC. The MAX5944 IC is a two-channel controller that performs hot-swapping, power-supply ORing, and current-limiting functions for FireWire™ applications. The MAX5944 controls n-channel MOSFETs to regulate load current from two input power supplies and performs low-voltage-drop power-supply ORing. The output current limit and input undervoltage-lockout thresholds are configurable.

The MAX5944 EV kit is intended for 7.5V to 37V FireWire power-supply applications. The current-limit threshold is configured to 1.6A per channel. Shutdown mode can be controlled with an on-board jumper. A fault output for each channel is provided for circuit monitoring.

*Firewire is a trademark of Apple Computer, Inc.*

## Ordering Information

PART	TEMP RANGE	IC PACKAGE
MAX5944EVKIT	0°C to +70°C	16 SO

## Features

- ◆ Safely Hot-Swaps 7.5V to 37V FireWire Power Supplies
- ◆ Demonstrates Two-Channel Hot-Swap
- ◆ Current Limit Configured for 1.6A per Channel
- ◆ Low-Voltage-Drop Power ORing
- ◆ Demonstrates Active Current-Limit Feature
- ◆ Programmable Load Current Limit
- ◆ 2ms Regulated Current-Limit Timeout
- ◆ Autoretry Fault Management
- ◆ Configurable Undervoltage Lockout
- ◆ Overcurrent  $\overline{\text{FAULTA}}$  and  $\overline{\text{FAULTB}}$  Output Status Indicators
- ◆ Surface-Mount Construction
- ◆ Fully Assembled and Tested

## Component List

DESIGNATION	QTY	DESCRIPTION
C1, C3	0	Not installed, electrolytic capacitors (16mm x 16.5mm)
C2, C5	2	1 $\mu$ F $\pm$ 10%, 50V X7R ceramic capacitors (1206) TDK C3225X7R1H105K
C4, C6	2	1 $\mu$ F $\pm$ 10%, 50V X7R ceramic capacitors (1210) TDK C3216X7R1H105K
C7, C8	2	1000pF $\pm$ 10%, 100V X7R ceramic capacitors (0603) TDK C1608X7R1H102K or Taiyo Yuden UMK107B102KZ
C9–C12	0	Not installed, ceramic capacitors (0603)
C13, C14	0	Not installed, electrolytic capacitors (8mm x10.2mm)
D1, D2	2	Red LEDs (0603)
J1, J2	2	IEEE 1394 FireWire vertical connectors
JU1, JU2, JU3	3	2-pin headers
N1, N2	2	40V, 7.2A, dual n-channel MOSFETs (8 SO PowerPAK) Vishay Si7958DP

DESIGNATION	QTY	DESCRIPTION
R1, R2	2	0.03 $\Omega$ $\pm$ 1%, 0.5W sense resistors (1206) IRC LRC-LR1206-01-R030-F
R3, R5	2	100k $\Omega$ $\pm$ 1% resistors (0603)
R4, R6, R7, R8, R13, R14	0	Not installed, resistors (0805)
R9–R12	4	4.7k $\Omega$ $\pm$ 5% resistors (1206)
R15	1	10k $\Omega$ $\pm$ 5% resistor (0603)
R16, R17	2	150k $\Omega$ $\pm$ 5% resistors (0603)
TP1, TP2, TP4, TP5, $\overline{\text{FAULTA}}$ , $\overline{\text{FAULTB}}$	6	Miniature PC test points (red)
TP3, TP6–TP10	6	Multipurpose PC test points (red)
TP11–TP14	4	Multipurpose PC test points (black)
VINA, OUTA, VINB, OUTB, PGND, PGND, PGND, PGND	8	Noninsulated banana-jack connectors
U1	1	MAX5944ESE (16-pin SO)
—	3	Shunts (JU1, JU2, JU3)
—	1	MAX5944 EV kit PC board

# MAX5944 Evaluation Kit

## Component Suppliers

SUPPLIER	PHONE	WEBSITE
IRC	361-992-7900	www.irctt.com
Taiyo Yuden	800-348-2496	www.t-yuden.com
TDK	847-803-6100	www.component.tdk.com
Vishay	203-268-6261	www.vishay.com

**Note:** Indicate that you are using the MAX5944 when contacting these component suppliers.

## Quick Start

### Required Equipment

- Two 35V, 2A adjustable power supplies
- Two voltmeters or one dual-channel oscilloscope

The MAX5944 EV kit is a fully assembled and tested surface-mount board. Follow the steps below for simple board operation. **Do not turn on the power supply until all connections are completed.**

- 1) Verify that shunts are not installed across jumpers JU1 (channel A enabled), JU2 (channel B enabled), and JU3 (ORing function enabled).
- 2) Connect a voltmeter across the OUTA and PGND EV kit PC-board pads.
- 3) Connect a voltmeter across the OUTB and PGND EV kit PC-board pads.
- 4) Connect the positive terminal of one power supply to the VINA banana jack. Connect the ground terminal of this power supply to the PGND banana jack.
- 5) Connect the positive terminal of the second power supply to the VINB banana jack. Connect the ground terminal of this power supply to the PGND banana jack.
- 6) Set both power supplies to 18V.
- 7) Turn on the power supplies.
- 8) Verify that the voltmeters connected to OUTA and OUTB outputs measure approximately 17.5V.
- 9) Verify that LEDs D1 and D2 are off (there are no fault conditions).
- 10) The EV kit is ready for further testing.

## Detailed Description

The MAX5944 EV kit demonstrates the ORing and hot-swap current-limiting functions of the MAX5944 two-channel controller. The MAX5944 controls a dual n-channel MOSFET (in a single SO8 package) in each channel to implement current regulation between the input power sources and the loads. The MAX5944 implements a low-drop ORing function that is required

for power-supply redundancy and fault isolation in high-reliability power systems. The MAX5944 EV kit board is designed to operate in 7.5V to 37V FireWire systems.

During a startup cycle, the two n-channel MOSFETs on each channel are off until the input voltage exceeds the internal 6.5V (typ) UVLO and the configurable ON\_ thresholds. Once the input voltage exceeds these two thresholds, the MAX5944 controller keeps the ORing MOSFET (N1-A or N2-B) off to prevent back charge from the output, and then slowly enhances the gate of the current-limiting MOSFET, N1-B or N2-A, to ramp the output current. When the voltage across the sense resistor exceeds the internal ORing voltage  $V_{OR}$  threshold, the MAX5944 turns on the ORing MOSFET. After the ORing and current-limiting MOSFETs have been turned on, the controller continues to monitor the output current by measuring the voltage across the sense resistor. If the output current exceeds the configured current-limit ( $I_{LIM}$ ) threshold, the controller lowers the gate voltage of the current-limiting MOSFET to regulate the output current at the limit. If the output current is not lowered to the programmed threshold within the timeout period of 2ms (typ), the controller turns off both MOSFETs and asserts a logic-low on the FAULT\_ output PC board pad to signal an overcurrent fault condition. The controller automatically restarts a new cycle after 259ms (typ).

The MAX5944 EV kit features jumpers to control the shutdown and ORing modes. The undervoltage-lockout threshold can be configured by installing resistors R4 and R6 on the EV kit board. LEDs D1 or D2 are turned on during a current-limit fault occurrence in channel A or channel B, respectively.

### Input Source

The MAX5944 EV kit can operate from a single 7.5V to 37V, 3.2A input source connected to both input channels VINA and VINB or two 1.6A power sources connected individually to each channel. Connect a power supply across VINA and PGND banana jacks to evaluate channel A. Connect a power supply across VINB and PGND banana jacks to evaluate channel B.

The MAX5944 EV kit controller turns on the respective MOSFETs when the input voltage exceeds the 6.5V(typ) VIN\_ default undervoltage lockout and the configurable ON\_ thresholds.

### Undervoltage Lockout Thresholds/Disable

The MAX5944 EV kit requires that the voltages at VIN\_ exceed the MAX5944 internal undervoltage threshold and the ON\_ pin voltage,  $V_{ON\_REF}$ , 1.24V (typ) threshold for normal operation. If these conditions are not met, the MAX5944 controller turns off either MOSFET

# MAX5944 Evaluation Kit

N1 or N2 to disconnect the VIN\_ input power supply from the output OUT\_. The controller returns to normal operation when these conditions are again met. The VIN\_ internal default undervoltage threshold is 6.5V (typ). The undervoltage threshold for channel A input VINA, or channel B input VINB, can be reconfigured by installing resistor R4 or R6, respectively. Use the following equations to select the new value for resistor R4 or R6:

$$R4 = \frac{R3}{\left(\frac{UV_A}{1.24V} - 1\right)}, \quad R6 = \frac{R5}{\left(\frac{UV_B}{1.24V} - 1\right)}$$

where UV<sub>A</sub> is the new undervoltage-lockout threshold for channel A, and UV<sub>B</sub> is the new undervoltage-lockout threshold for channel B. Resistors R3 and R5 are 100kΩ.

The MAX5944 EV kit channel A or channel B can be disabled by installing a shunt on jumper JU1 or JU2, respectively, which connect the ON\_ pins to ground. The MAX5944 controller turns off the respective MOSFETs when the channel is disabled. See Table 1 and Table 2 for jumper JU1 and JU2 configurations.

**Table 1. Jumper JU1 Configuration**

SHUNT POSITION	ONA PIN CONNECTION	EV KIT FUNCTION
Not installed	Connected to VINA through resistor R3	Channel A enabled
Installed	Connected to GND	Channel A disabled

**Table 2. Jumper JU2 Configuration**

SHUNT POSITION	ONB PIN CONNECTION	EV KIT FUNCTION
Not installed	Connected to VINB through resistor R5	Channel B enabled
Installed	Connected to GND	Channel B disabled

## Power-Supply ORing

The MAX5944 EV kit ORing function can be enabled or disabled by configuring jumper JU3. See Table 3 for jumper JU3 configuration.

**Table 3. Jumper JU3 Configuration**

SHUNT POSITION	ONQ1 PIN CONNECTION	EV KIT FUNCTION
Not installed	Connected to GND through resistor R5	ORing enabled
Installed	Connected to VINA	ORing disabled

When the ORing function is disabled, the MAX5944 controller fully enhances the ORing MOSFETs N1-A and N2-B during normal operation, regardless of the load-current condition. In this mode, current can flow from the output OUT\_ to the input VIN\_ if the voltage present at the OUT\_ terminal is higher than the voltage at the VIN\_ terminal. There is no active reverse current limiting in this mode.

When the ORing function is enabled, the MAX5944 controller turns the respective ORing MOSFET on or off, depending on the load current conditions. Initially, during startup, the ORing MOSFET is turned off and the load current conducts through the MOSFET's body diode. The MAX5944 controller turns on the ORing MOSFET when the voltage across the respective current-sense resistor exceeds the 5mV(typ) V<sub>OR</sub> threshold. The controller continues to monitor the voltage across the sense resistor and turns off the MOSFET when that voltage drops below the V<sub>OR</sub> threshold. When the ORing MOSFET is turned off, current cannot back-drive the input source VIN\_ if the voltage at OUT\_ is higher than the VIN\_ voltage.

# MAX5944 Evaluation Kit

## Current Limiting

The MAX5944 EV kit limits the output current to the configured current-limit ( $I_{LIM}$ ) threshold, by monitoring the voltage across the current-sense resistor and regulating the GATE2\_ voltage and causing the current-limiting MOSFET (N1-B or N2-A) to act like a current source. The MAX5944 EV kit  $I_{LIM}$  thresholds are configured to 1.6A with 30m $\Omega$  current-sense resistors, R1 and R2, for channel A and channel B, respectively. When the load current is less than  $I_{LIM}$ , the current-limiting MOSFET is fully enhanced. When the load current attempts to exceed  $I_{LIM}$ , the MOSFET gate voltage is reduced to regulate the output current. If the load current demand exceeds  $I_{LIM}$  for longer than the current-limit timeout period of 2ms, MOSFET N1 or N2 is turned off to disconnect the load. The  $\overline{FAULT\_PC}$  board output pad is also asserted low and the corresponding fault LED is turned on.

The output  $I_{LIM}$  is determined by the value of sense resistors and the current-limit voltage threshold ( $V_{TH}$ ) across the sense resistor. The MAX5944  $V_{TH}$  threshold is 50mV (typ).

Change current-sense resistors R1 or R2 for channel A or channel B respectively, to reconfigure the output current limits. Use the following equations to select new resistor values:

$$R1 = \frac{V_{TH}}{I_{LIM1}}, \quad R2 = \frac{V_{TH}}{I_{LIM2}}$$

where  $V_{TH}$  is 50mV and  $I_{LIM1}$  and  $I_{LIM2}$  are the new output current limits. Choose a sense resistor that is rated for the new power-dissipation levels. Verify that the power ratings for MOSFETs N1 and N2 meet the new operating conditions.

## $\overline{FAULT\_A}$ and Autoretry

The MAX5944 EV kit  $\overline{FAULT\_A}$  and  $\overline{FAULT\_B}$  output signals are high-voltage outputs that are asserted low when a current-limit fault condition has occurred. The  $\overline{FAULT\_A}$  output is pulled up to VINA during normal operating conditions on channel A. The  $\overline{FAULT\_B}$  output is pulled up to VINB during normal operating conditions on channel B. During a current-limit fault event, the

MAX5944 turns off the affected channel's MOSFET and asserts a logic-low signal on the  $\overline{FAULT\_}$  output. Red LED D1 or D2 is turned on during a current-limit fault condition at channel A or channel B, respectively.

The MAX5944 automatically attempts to restart 259ms (typ) after a current-limit fault condition has occurred. The  $\overline{FAULT\_}$  outputs are cleared every restart cycle.

## EV Kit Reconfiguration

The MAX5944 EV kit can be configured to simulate a FireWire power bus system with two input power supplies or a single power-supply powering two FireWire ports.

To simulate a FireWire power bus with two input power supplies, connect independent power supplies to the VINA and to the VINB banana-jack input connectors, and then connect the OUTA and OUTB banana jacks with one 4A-rated cable.

To simulate a single power-supply powering two FireWire ports, connect a 4A power supply to the VINA and PGND banana-jacks. Then connect the VINA banana jack to the VINB banana jack. Connect two independent loads to the OUTA and to the OUTB banana jacks. FireWire port connectors are also available on the EV kit for power and ground-pin-connection evaluation. FireWire port connector J1 is used for channel A and FireWire port connector J2 is used for channel B. The FireWire ports J1 and J2 do not have connections to the signal pins.

Multiple MAX5944 EV kits can be connected together to simulate the implementation of power-supply ORing and hot-swapping in FireWire power systems. Connect the OUT\_ outputs of two or more EV kits, as well as their respective ground (PGND) connections, to simulate a FireWire system with multiple power sources. Connect independent power supplies to the VIN\_ input of each EV kit. Start up each power supply independently and observe the undervoltage lockout, ORing, and current-limit feature in each EV kit. Once all the power supplies are turned on, induce fault conditions on the power bus. **Note:** Each EV kit can be configured for different limits and thresholds for a better evaluation of the MAX5944 functions.

# MAX5944 Evaluation Kit

Evaluates: MAX5944

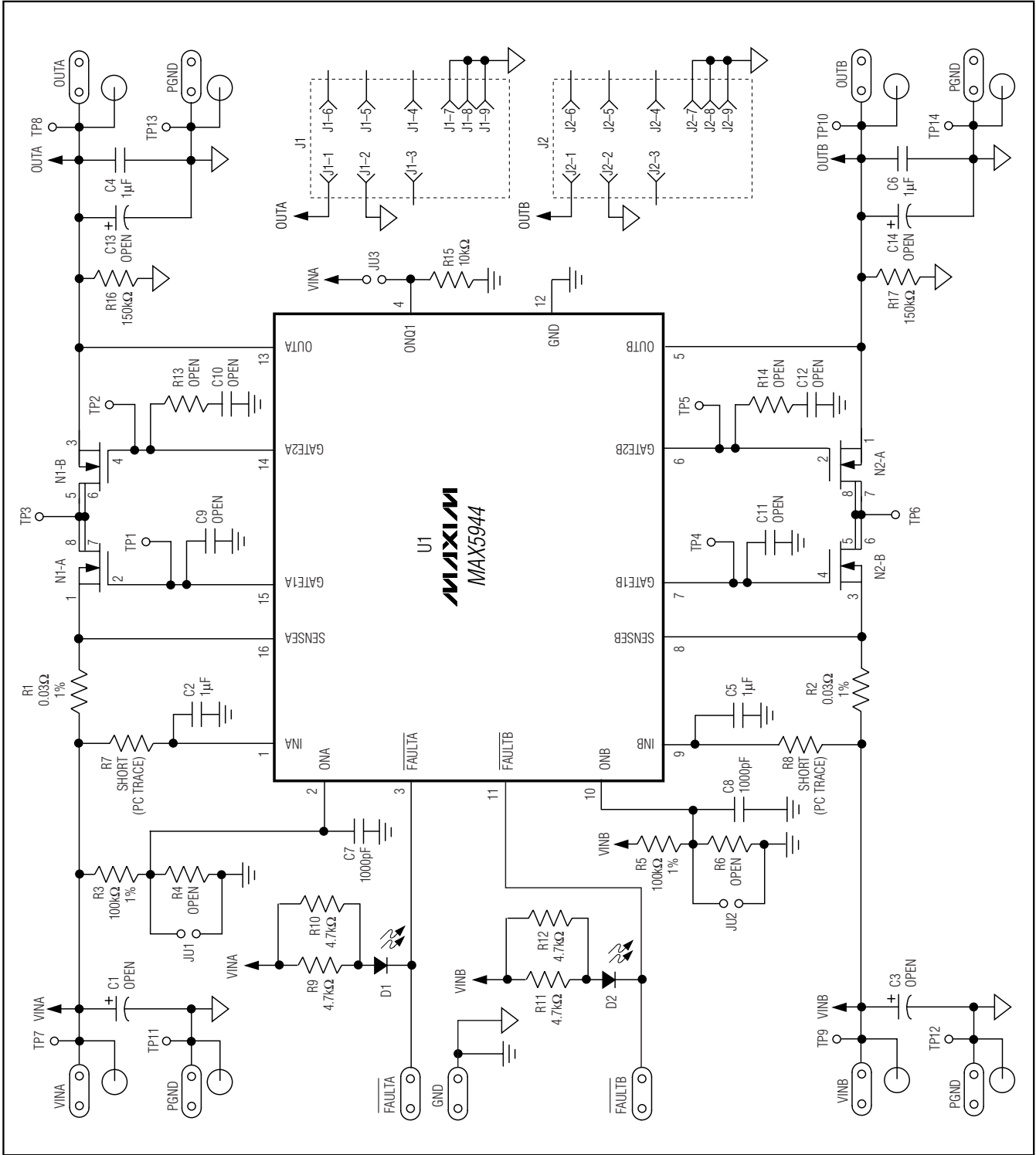

Figure 1. MAX5944 EV Kit Schematic

# MAX5944 Evaluation Kit

Evaluates: MAX5944

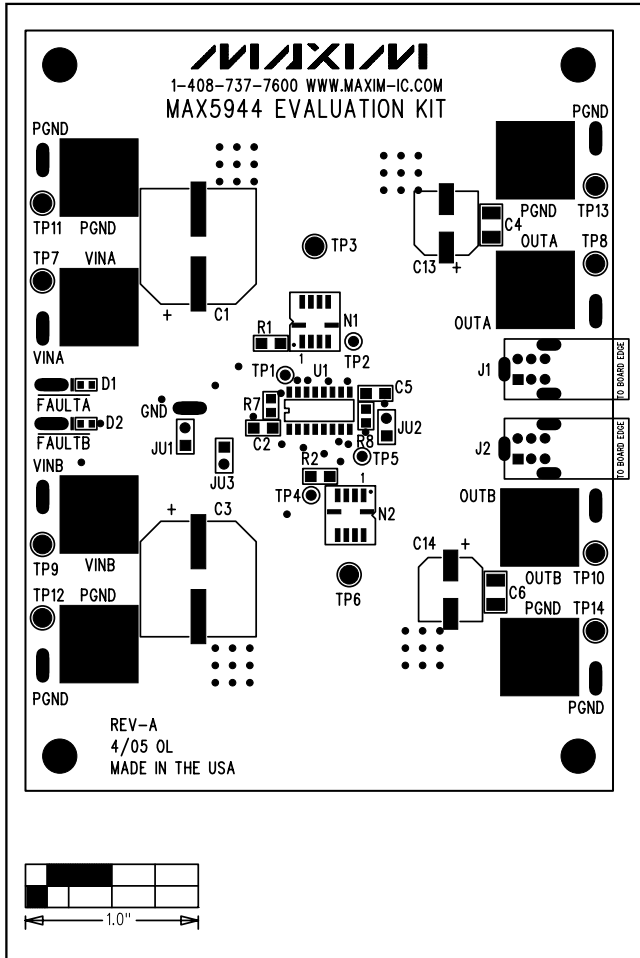

Figure 2. MAX5944 EV Kit Component Placement Guide—Component Side

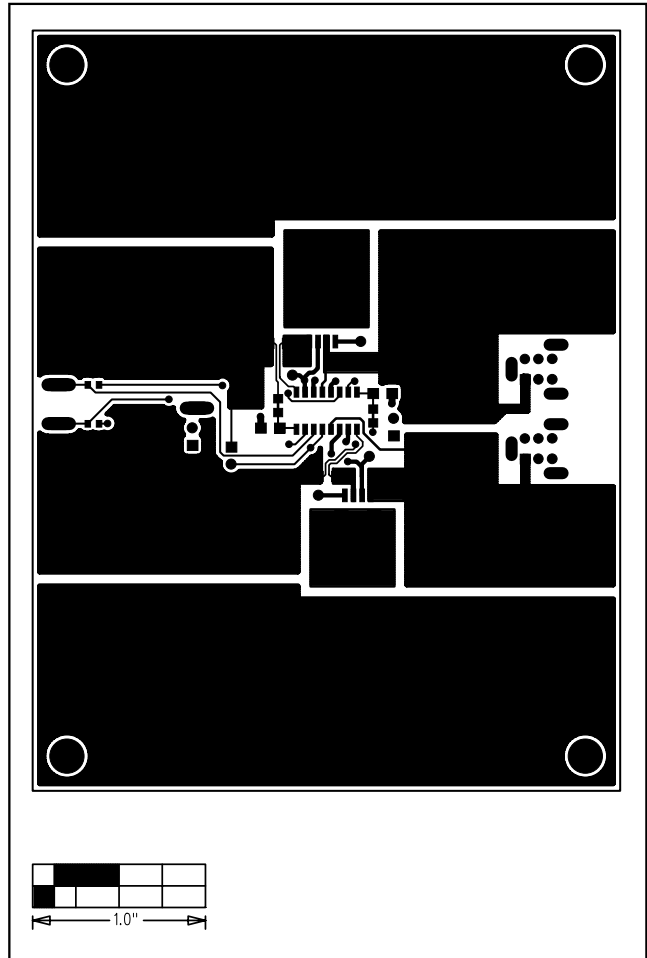

Figure 3. MAX5944 EV Kit PC Board Layout—Component Side

# MAX5944 Evaluation Kit

Evaluates: MAX5944

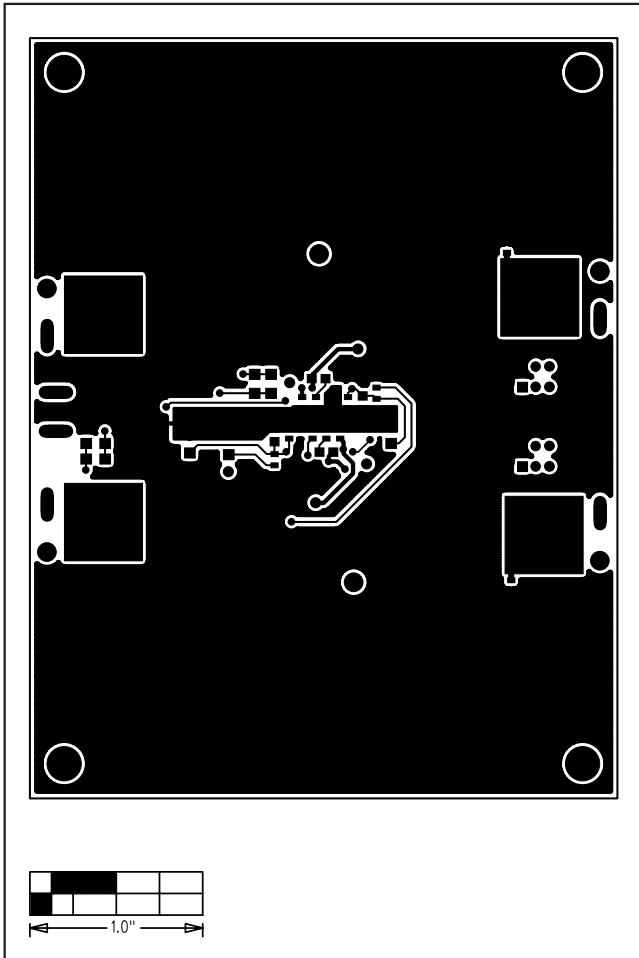

Figure 4. MAX5944 EV Kit PC Board Layout—Solder Side

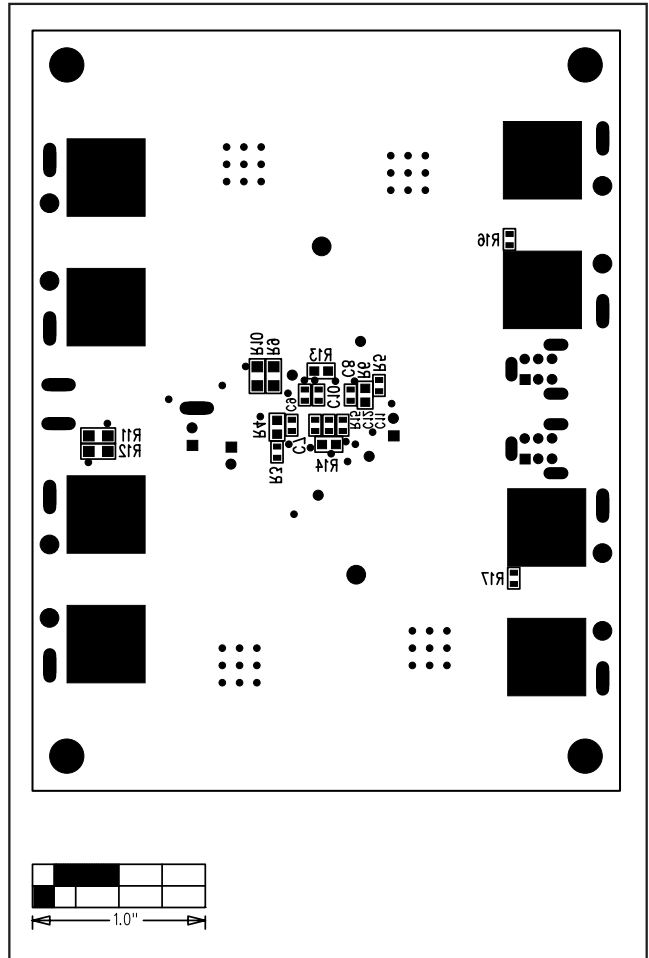

Figure 5. MAX5944 EV Kit Component Placement Guide—Solder Side

Maxim cannot assume responsibility for use of any circuitry other than circuitry entirely embodied in a Maxim product. No circuit patent licenses are implied. Maxim reserves the right to change the circuitry and specifications without notice at any time.

Maxim Integrated Products, 120 San Gabriel Drive, Sunnyvale, CA 94086 408-737-7600 \_\_\_\_\_ 7