



# MAX3877/MAX3878 Evaluation Kits

## General Description

The MAX3877/MAX3878 evaluation kits (EV kits) simplify evaluation of the MAX3877/MAX3878 2.5Gbps clock-recovery and data-retiming ICs. These EV kits enable testing of all MAX3877 and MAX3878 functions. SMA connectors are provided for the differential inputs and outputs.

The MAX3877 has CML outputs and the MAX3878 has PECL outputs. Both the MAX3877 and MAX3878 EV kits come complete with on-board output structures to allow direct connection to 50Ω oscilloscopes and test equipment.

## Features

- ◆ SMA Connections for All High-Speed I/Os
- ◆ Test Points for Monitoring  $\overline{\text{LOL}}$  and LOS
- ◆ Single +3.3V Power-Supply Operation
- ◆ Fully Assembled and Tested

## Ordering Information

PART	TEMP. RANGE	IC PACKAGE
MAX3877EVKIT	-40°C to +85°C	32 TQFP-EP*
MAX3878EVKIT	-40°C to +85°C	32 TQFP-EP*

\* Exposed pad

## Component List

DESIGNATION	QTY	DESCRIPTION
C1–C10, C12–C16, C21–C26, C29, C30	23	0.1μF ±10% ceramic capacitors (0603)
C11	1	1μF ±10% ceramic capacitor (1206)
C17, C18, C27, C28	4	0.1μF capacitors (0603) (MAX3877EVKIT) 0Ω resistors (0603) (MAX3878EVKIT)
C19	1	33μF ±20%, 10V min tantalum capacitor
C20	1	2.2μF ±10% ceramic capacitor (1206)
R1, R2	2	392Ω ±1% resistors (0603)
R3, R5	2	10kΩ variable resistors Digi-Key 3296W-103-ND
R4, R6	2	3.6kΩ ±5% resistors (0603)
R7, R11, R15, R19	4	0Ω resistors (0402) (MAX3877EVKIT) 24Ω resistors (0402) (MAX3878EVKIT)
R8, R12, R16, R20	4	0Ω resistors (0402) (MAX3877EVKIT) 27Ω resistors (0402) (MAX3878EVKIT)
R9, R13, R17, R21	4	Open (MAX3877EVKIT) 130Ω resistors (0402) (MAX3878EVKIT)
R10, R14, R18, R22	4	Open (MAX3877EVKIT) 220Ω resistors (0402) (MAX3878EVKIT)
L1, L2, L3, L4	4	56nH inductors Coilcraft 0805HS-560TKBC

DESIGNATION	QTY	DESCRIPTION
U1	1	MAX3877EHJ (5mm 32-pin TQFP-EP) (MAX3878EVKIT) MAX3878EHJ (5mm 32-pin TQFP-EP) (MAX3878EVKIT)
D1	1	Red LED
D2	1	Green LED
TP1, TP2	2	Test points
JP1, JP4	2	2-pin headers (0.1in centers)
JP2, JP5, JP6, JP10	4	3-pin headers (0.1in centers)
JP2, JP5, JP6, JP10	4	Shunts
JP7	1	Not installed
J1–J8	8	SMA connectors (edge-mount) Johnson 142-0701-801 or Digi-Key J502-ND
J9, J10	2	V <sub>CC</sub> , GND
None	1	MAX3877/MAX3878 EV kit circuit board, Rev C
None	1	MAX3877/MAX3878 data sheet
None	1	MAX3877/MAX3878 EV kit data sheet

Evaluate: MAX3877/MAX3878

# MAX3877/MAX3878 Evaluation Kits

## Detailed Description

These EV kits are fully assembled and factory tested. They enable testing of all chip functions.

### Test Equipment Required

- +3.3V power supply with 300mA current capability
- Signal source, 2.5Gbps minimum capability
- Jitter analyzer capable of 2.5Gbps performance
- Oscilloscope with at least 3GHz performance

### Connections

The serial data inputs (SDI $\pm$ , SLBI $\pm$ ) have on-board AC-coupling capacitors. All of the outputs (SDO $\pm$ , SCLKO $\pm$ ) are terminated to allow direct connection to 50 $\Omega$  oscilloscopes or test equipment.

### Quick Start

- 1) Verify that there is a shunt across the SDI ENABLE side of jumper JP10.
- 2) Verify that there is a shunt across the REF DISABLE side of jumper JP6.
- 3) Verify that there is a shunt across the PHADJ DISABLE side of jumper JP2.
- 4) Verify that there is a shunt across the THADJ DISABLE side of jumper JP5.
- 5) Connect +3.3V and ground to the appropriate terminals of the EV kit.
- 6) Connect a 2.5Gbps PRBS NRZ signal to the SDI $\pm$  inputs with 50 $\Omega$  cables.
- 7) Connect the outputs to a 50 $\Omega$  high-speed oscilloscope.

Jitter analysis and product performance can also be observed by appropriately interfacing the EV kit with a bit-error-rate tester (BERT) and a jitter analyzer.

### MAX3877 EV Kit Output Terminations

The MAX3877 EV kit has on-board AC-coupling capacitors to allow direct connection of the EV kit outputs to 50 $\Omega$  equipment.

### MAX3878 EV Kit Output Terminations

The MAX3878 EV kit has on-board termination networks on all high-speed outputs (SDO $\pm$ , SCLKO $\pm$ ) to interface PECL outputs directly to 50 $\Omega$  oscilloscopes or test equipment. The on-board interfaces perform the level shifting and attenuation required to interface PECL outputs to 50 $\Omega$  loads. The attenuation from the network is about 6dB, or half of the voltage swing.

**Table 1. Jumpers, Controls and Test Points**

NAME	TYPE	DESCRIPTION	NORMAL POSITION
JP1	2-Pin Header	Short to disable DC-offset/pulse-width distortion cancellation	Open (Enabled)
JP2	3-Pin Header	Disable/Enable phase adjust function	PHADJ DISABLE
JP4	2-Pin Header	Short to disable PLL filter	Open (Enabled)
JP5	3-Pin Header	Disable/Enable threshold adjust function	VTH DISABLE
JP6	3-Pin Header	Select between SDI and SLBI. Refer to data sheet.	REF DISABLE
JP10	3-Pin Header	Select between SDI and SLBI. Refer to data sheet.	SDI ENABLE
TP1	Test Point	$\overline{LOL}$ test point	—
TP2	Test Point	LOS test point	—
R3	Potentiometer	Used to adjust PHADJ control voltage	—
R5	Potentiometer	Used to adjust THADJ control voltage	—

# MAX3877/MAX3878 Evaluation Kits

Evaluate: MAX3877/MAX3878

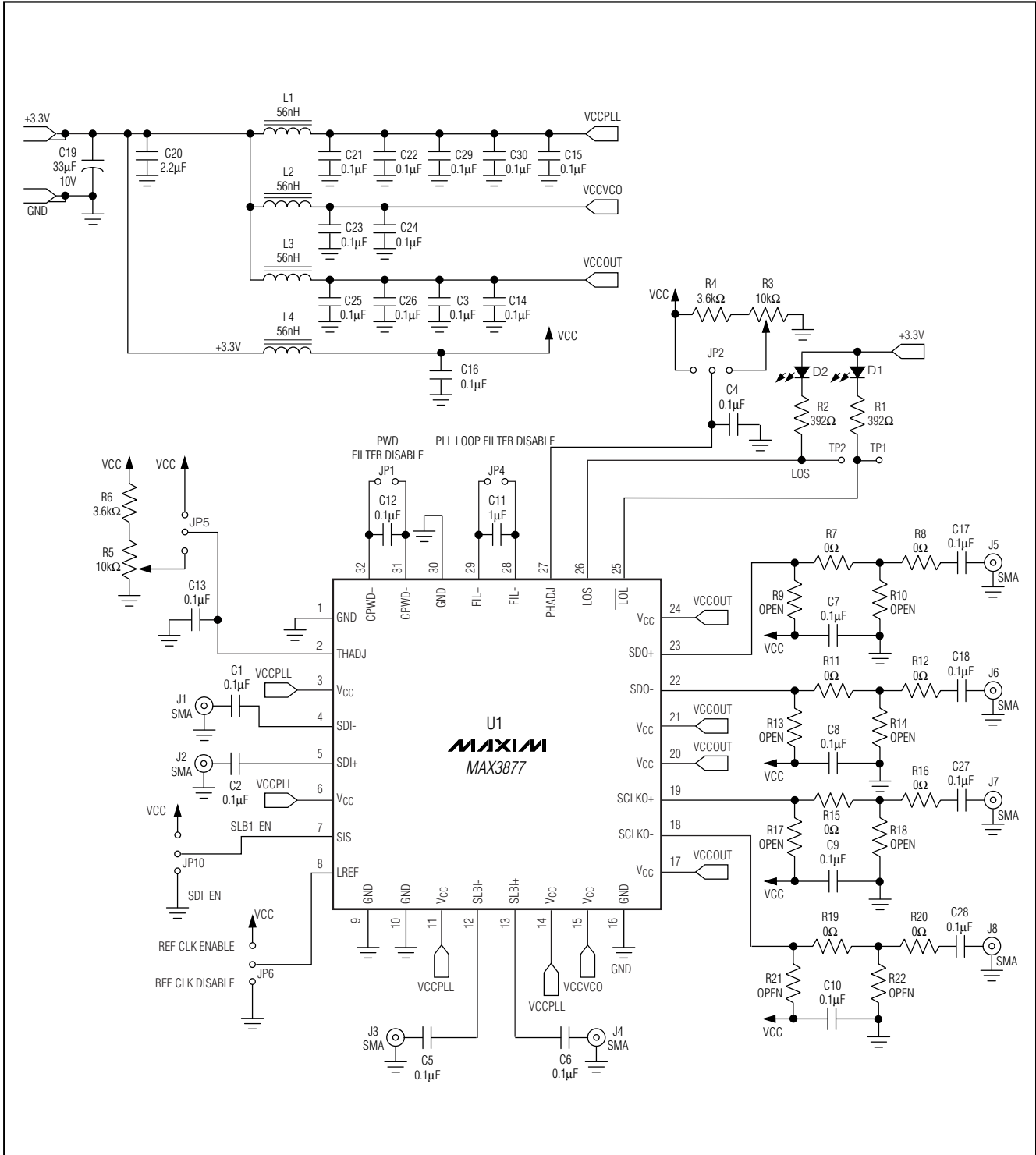

Figure 1. MAX3877 EV Kit Schematic



# MAX3877/MAX3878 Evaluation Kits

Evaluate: MAX3877/MAX3878

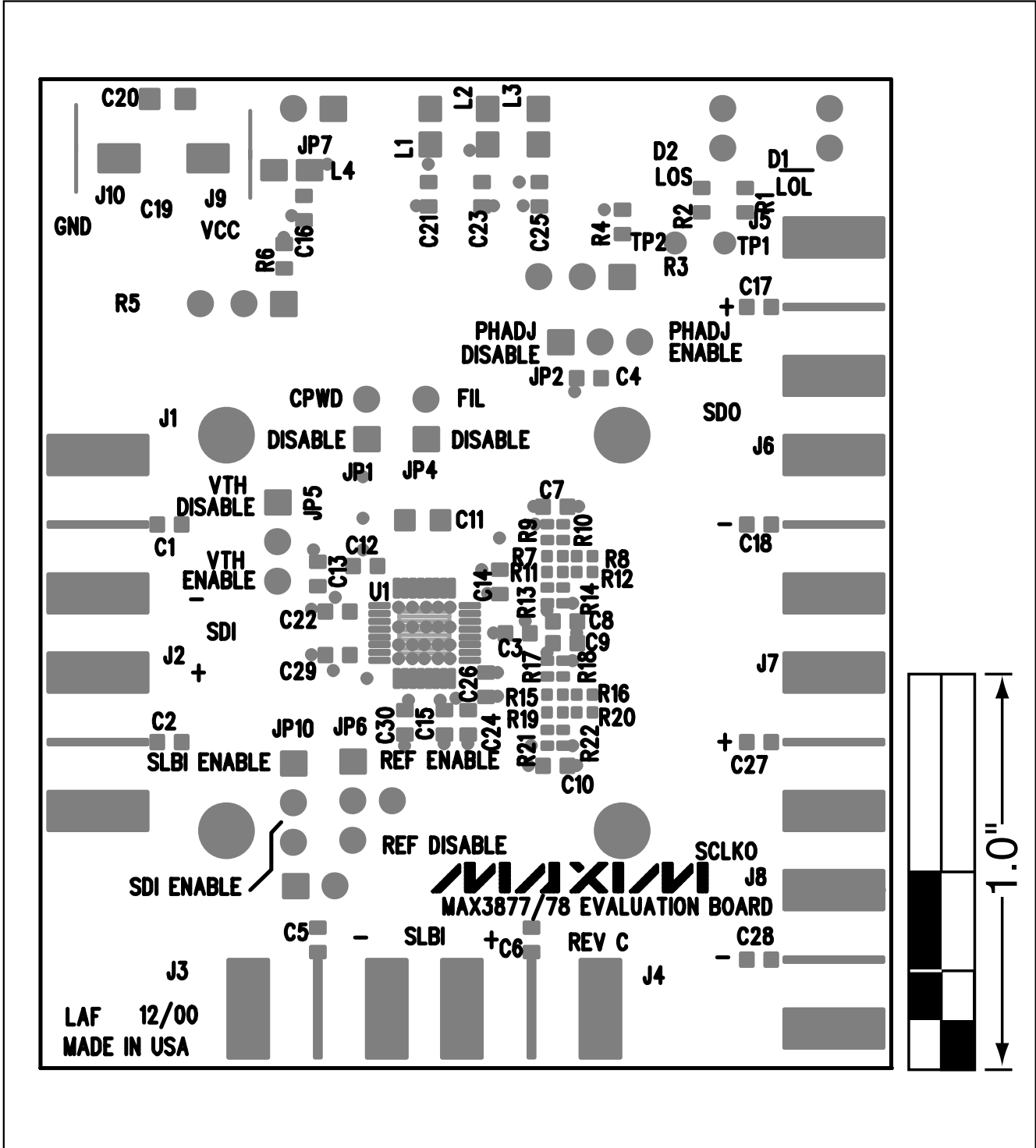

Figure 3. MAX3877/MAX3878 EV Kit Component Placement Guide—Component Side

# MAX3877/MAX3878 Evaluation Kits

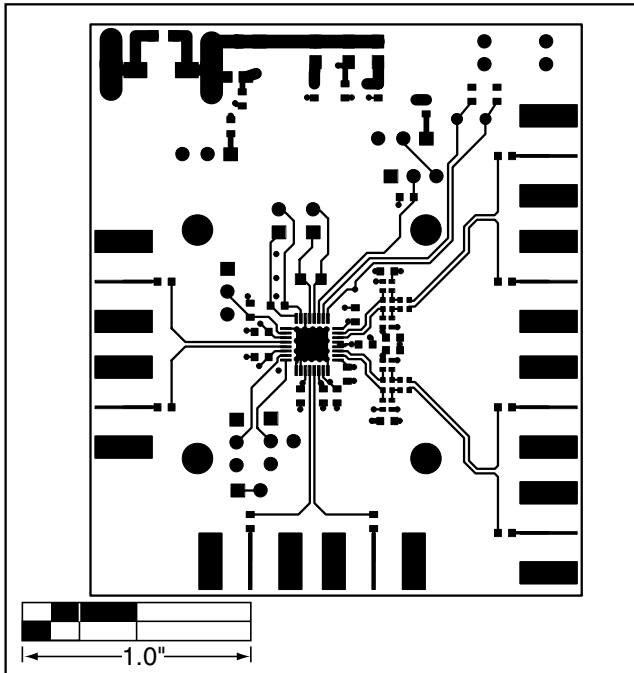

Figure 4. MAX3877/MAX3878 EV Kit PC Board Layout—Component Side

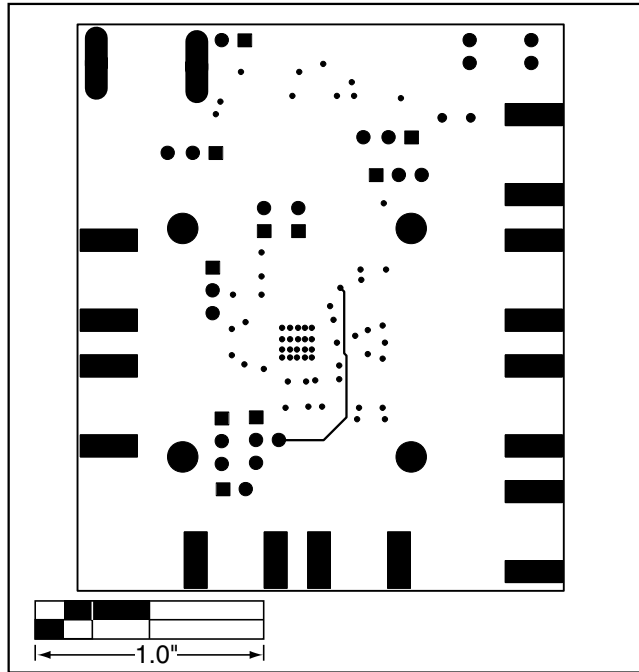

Figure 5. MAX3877/MAX3878 EV Kit PC Board Layout—Solder Side

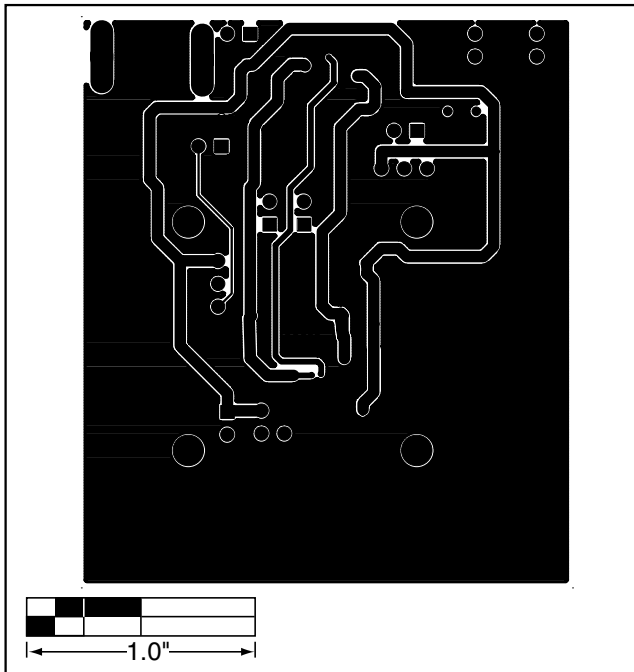

Figure 6. MAX3877/MAX3878 EV Kit PC Board Layout—Power Plane

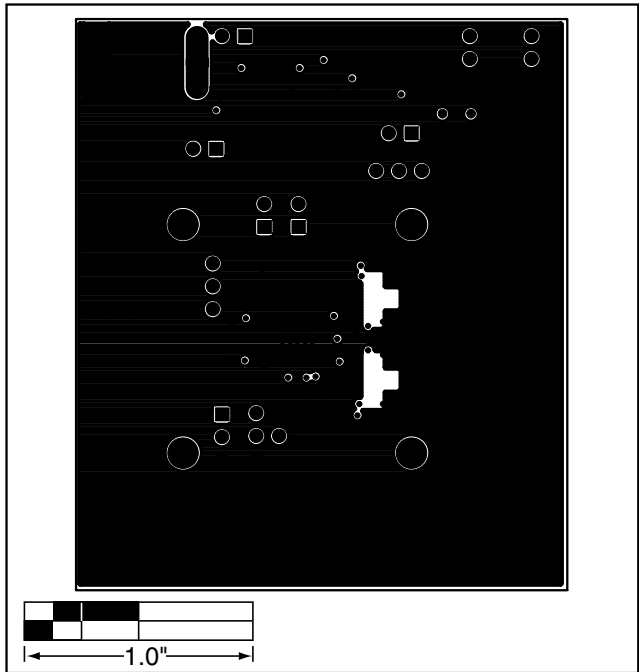

Figure 7. MAX3877/MAX3878 EV Kit PC Board Layout—Ground Plane

Maxim cannot assume responsibility for use of any circuitry other than circuitry entirely embodied in a Maxim product. No circuit patent licenses are implied. Maxim reserves the right to change the circuitry and specifications without notice at any time.

6 \_\_\_\_\_ **Maxim Integrated Products, 120 San Gabriel Drive, Sunnyvale, CA 94086 408-737-7600**