

MAXIM

MAX1926 Evaluation Kit

General Description

The MAX1926 evaluation kit (EV kit) is a complete, fully assembled and tested, single-cell lithium-ion (Li+) battery charger. The EV kit provides a 4.2V output from input as high as 12V, and delivers up to 1A charge current. A light-emitting diode (LED) indicates the cell's charging status.

The EV kit can be also used to evaluate the MAX1925, which is a single-cell Li+ battery charger with a 4.5V to 6.1V input voltage charge range.

Component List

DESIGNATION	QTY	DESCRIPTION
C1	1	10 μ F \pm 20%, 16V X5R ceramic capacitor (1210) Taiyo Yuden EMK325BJ106MN or TDK C3225X5R1C106MT
C2	1	22 μ F \pm 20%, 6.3V tantalum capacitor (A case) AVX TAJA226M006R
C3	1	0.1 μ F \pm 10%, 16V X7R ceramic capacitor (0603) Taiyo Yuden EMK107BJ104KA or TDK C1608X7R1C104KT or Murata GRM39X7R104K016AD
C4	0	Not installed, capacitor (0603)
D1, D2	2	1A, 30V Schottky diodes Nihon EP10QY03
D3	1	Surface-mount LED (0805)
JU1	1	2-pin header
JU2	0	Not installed, shorted by PC trace
L1	1	10 μ H, 1.3A inductor Toko A915AY-100M or Sumida CDRH5D28-100
Q1	1	P-channel MOSFET 3-pin SOT23 Fairchild FDN360P
R1	1	0.14 Ω \pm 1%, 1/2W sense resistor (1206) IRC LR1206-01-R140-F
R2	1	100k Ω \pm 5% resistor (0603)
R3, R4	0	Not installed, resistors (0603)
R5	1	10k Ω \pm 5% resistor (0603)
U1	1	MAX1926ETC 12-pin thin QFN 4mm x 4mm, top mark AABF
None	1	Shunt
None	1	MAX1926 PC board

Features

- ◆ 5V to 12V Input Voltage Range
- ◆ Up to 1A Fast Charge Current
- ◆ LED Charge Status and Fault Indicator
- ◆ 12-Pin Thin QFN Package
- ◆ Surface-Mount Construction
- ◆ Fully Assembled and Tested

Ordering Information

PART	TEMP RANGE	IC PACKAGE
MAX1926EVKIT	0°C to +70°C	12 Thin QFN 4mm x 4mm

Note: To evaluate the MAX1925, request a MAX1925 free sample with the MAX1926EVKIT.

Quick Start

The MAX1926 EV kit is a fully assembled and tested surface-mount board. Follow the steps below to verify board operation. **Do not turn on the power supply until all connections are completed:**

- 1) Verify that there is a no shunt across jumper JU1 (EN).
- 2) Connect a voltmeter across the EV kit's BATT and GND pads.
- 3) Connect a 5V to 12V power supply to the VIN pad. Connect the power-supply ground to the GND pad closest to VIN.
- 4) **Observe correct Li+ cell polarity.** Connect the positive terminal of a single-cell Li+ battery to the BATT pad. Connect the negative terminal of the battery to the GND pad closest to BATT.
- 5) Turn on the power supply. The LED turns on if the battery voltage is below 4.2V and the charging current is above 125mA. See Table 3 for additional LED state descriptions.
- 6) The LED turns off once the Li+ cell has been fully charged.

To evaluate the MAX1925, see the *Evaluating the MAX1925* section.

Evaluates: MAX1925/MAX1926

MAX1926 Evaluation Kit

Component Suppliers

SUPPLIER	PHONE	FAX	WEBSITE
AVX	843-946-0238	843-626-3123	www.avxcorp.com
Fairchild	888-522-5372	408-882-2102	www.fairchildsemi.com
IRC	361-992-7900	361-992-3377	www.irctt.com
Murata	770-436-1300	770-436-3030	www.murata.com
Nihon	81-33343-3411	81-33342-5407	www.niec.co.jp
Sumida	847-545-6700	847-545-6720	www.sumida.com
Taiyo Yuden	800-348-2496	847-925-0899	www.t-yuden.com
TDK	847-803-6100	847-390-4405	www.component.tdk.com
Toko	847-297-0070	847-699-1194	www.tokoam.com

Note: Please indicate that you are using the MAX1925/MAX1926 when contacting these component suppliers.

Detailed Description

The MAX1926 EV kit is a fully assembled and tested single-cell Li+ battery charger. The EV kit contains an external P-channel MOSFET for current switching and can deliver up to 1A of current to a Li+ battery. An LED indicates the charging status of the battery. The maximum charging time is set to 3 hours with 0.1 μ F at C3.

Jumper Selection

In the MAX1926, EN is internally pulled to 3V with an internal 300k Ω resistance. When jumper JU1 is open, EN goes to 3V and the charger is enabled. When JU1 is shorted, EN is 0V and the charger is disabled. See Table 1 for JU1 functions

In the MAX1925, EN does not have an internal pullup and must be driven high (5.5V max) or low. Extra pads (R3 and R4) are provided so that EN can be driven from a voltage-divider connected to a higher voltage without exceeding the 5.5V limit.

Jumper JU2 provides options to connect THRM to a thermistor or a 10k Ω resistor. The MAX1926 is disabled when

the resistance connected to THRM is greater than 28.69 Ω or less than 3.967k Ω . The MAX1926 EV kit comes with THRM connected to a 10k Ω resistor. JU2 is not populated and is shorted by a PC trace. To connect a thermistor to the EV kit, cut open the PC trace shorting JU2. Table 2 lists JU2 functions.

LED States

The LED on the EV kit is driven by the CHG pin. Depending on the Li+ cell's charging status, the pin is low or high impedance, thus turning the LED on or off. The LED blinks at 0.5Hz when the MAX1926 enters Fault Prequal1, Fault Prequal 2, Fault Full, Fault BATT Voltage, or the Fault Temp state. For driving logic circuits, remove the LED and install a pullup resistor from a logic supply to CHG. Table 3 lists the LED states.

Evaluating the MAX1925

To evaluate the MAX1925, replace the MAX1926ETC with a MAX1925ETC. Install 100k Ω resistors R3 and R4 to enable the IC.

Table 1. JU1 Functions

SHUNT LOCATION	EN PIN	MAX1926 OUTPUT
Installed	Connected to GND	MAX1926 is disabled
Not installed	EN internally pulled to 3V	MAX1926 is enabled

Table 2. JU2 Functions

JUMPER STATE	THRM PIN	MAX1926 OUTPUT
Open	Connected to a thermistor using THRM pad	MAX1926 enabled with valid THRM resistance and EN high
Shorted (by Default)	Connect to a 10k Ω pulldown resistor	MAX1926 is enabled if EN is high

MAX1926 Evaluation Kit

Evaluates: MAX1925/MAX1926

Table 3. LED States

CHARGING STATE	CONDITION	LED STATE
Off	EN low, or no battery, or no wall power.	Off.
Prequal1	Charge current = 4mA until BATT reaches 2V.	On.
Prequal2	Charge current = C/10 (100mA) until BATT reaches 3V.	On.
Fast Charge	Charge current = C = 142mV/R1 (1A).	On.
Full Charge	Charge current has fallen to C/8 (125mA).	Off.
Fault Prequal1	BATT does not reach 2V before Prequal1 timeout.	Blinking at 0.5Hz. Clear fault by cycling input power, THRM, or EN.
Fault Prequal2	BATT does not reach 3V before Prequal2 timeout.	
Fault Full	Charge current does not drop to C/8 (125mA) before full-charge timeout.	
Fault Batt Voltage	Battery voltage has exceeded 4.35V.	
Fault Temp	Temperature has risen above +50°C or fallen below 0°C if a thermistor is installed. Temp fault clears by itself.	MAX1925: Off. MAX1926: Blinking at 0.5Hz.
None	Initial power-up or enable with no battery.	Blinking at rapid rate as charger cycles through Reset, Prequal1, and Done.

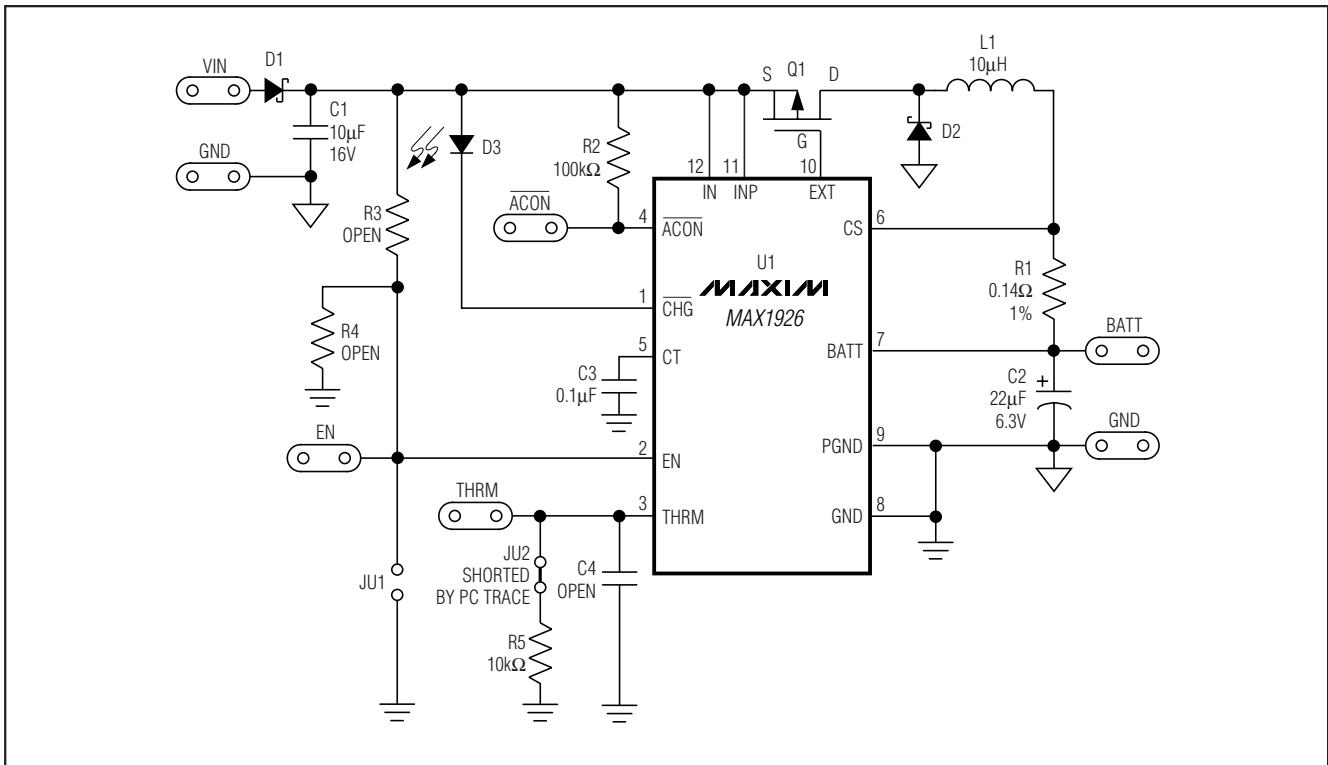

Figure 1. MAX1926 EV Kit Schematic

MAX1926 Evaluation Kit

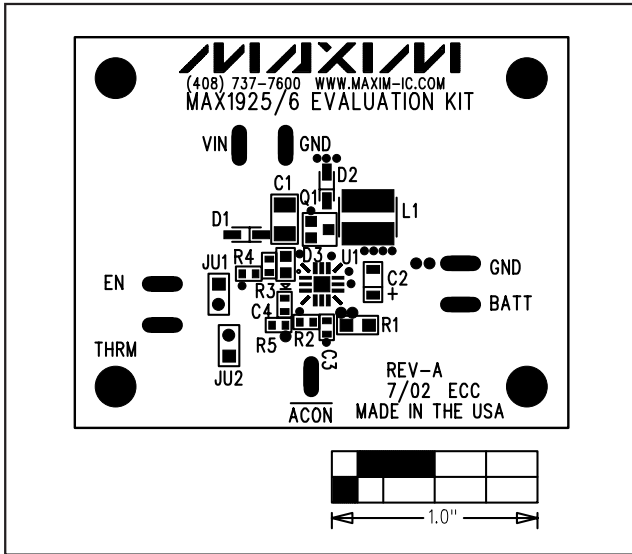

Figure 2. MAX1926 EV Kit Component Placement Guide—Top Silkscreen

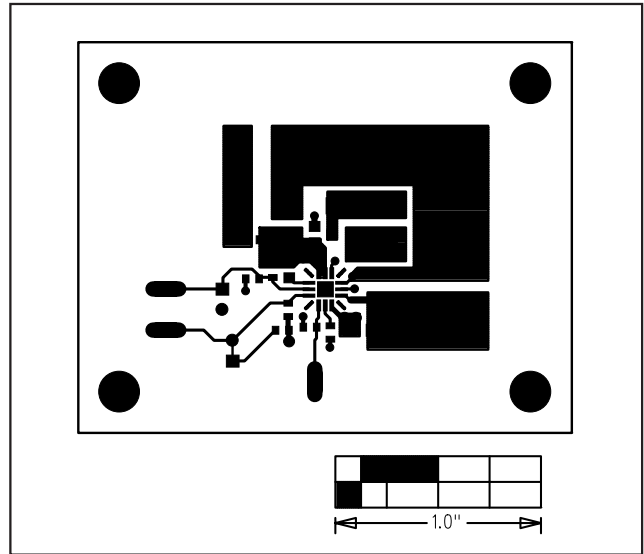

Figure 3. MAX1926 EV Kit PC Board Layout—Component Side

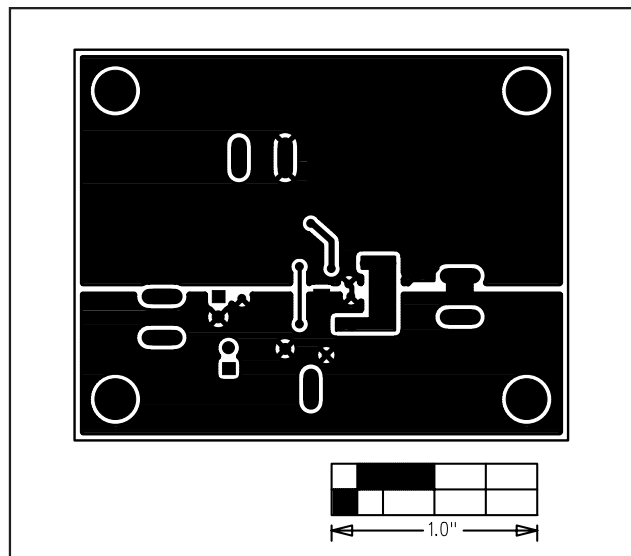

Figure 4. MAX1926 EV Kit PC Board Layout—Solder Side

Maxim cannot assume responsibility for use of any circuitry other than circuitry entirely embodied in a Maxim product. No circuit patent licenses are implied. Maxim reserves the right to change the circuitry and specifications without notice at any time.

4 **Maxim Integrated Products, 120 San Gabriel Drive, Sunnyvale, CA 94086 408-737-7600**