

MAXIM

MAX1717 Evaluation Kit

Evaluates: MAX1717

General Description

The MAX1717 evaluation kit (EV kit) demonstrates a high-power, dynamically adjustable notebook CPU application circuit. The MAX1717 DC-DC converter steps down high-voltage batteries and/or AC adapters, generating a precision, low-voltage CPU core VCC rail. The MAX1717 EV kit meets the Intel mobile Pentium® III CPU's transient voltage specification by using voltage positioning to minimize output capacitor requirements.

This fully assembled and tested circuit board provides a digitally adjustable 0.925V to 2V output voltage from a 7V to 24V battery input range. It delivers up to 12A output current with 14.1A peak current. The EV kit operates at 300kHz switching frequency and has superior line- and load-transient response. Output slew-rate control minimizes battery and inductor surge currents. With its precision timer circuit, the MAX1717's output voltage slew rate can be tailored to a given application, providing "just-in-time" arrival at the new DAC setting.

Ordering Information

PART	TEMP. RANGE	IC PACKAGE
MAX1717EVKIT	0°C to +70°C	24 QSOP

Features

- ◆ High Speed, Accuracy, and Efficiency
- ◆ Voltage-Positioned Output
- ◆ Lowest Output Capacitor Count (4)
- ◆ Reduces CPU Power Consumption
- ◆ Fast-Response Quick-PWM™ Architecture
- ◆ 7V to 24V Input Voltage Range
- ◆ 0.925V to 2V Output Voltage Range
- ◆ 12A Load-Current Capability (14.1A peak)
- ◆ Controlled Input Surge Current During Output Transition
- ◆ 300kHz Switching Frequency
- ◆ No Current-Sense Resistor
- ◆ VGATE Power-Good/Transition-Complete Indicator
- ◆ 24-Pin QSOP Package
- ◆ Low-Profile Components
- ◆ Fully Assembled and Tested

Component List

DESIGNATION	QTY	DESCRIPTION
C1-C4, C20	5	10µF, 25V ceramic capacitors (1812) Taiyo Yuden TMK432BJ106KM or Tokin C34Y5U1E106Z
C5, C6, C7	3	220µF, 2.5V, 15mΩ low-ESR specialty polymer capacitors Panasonic EEFUE0E221R
or	or	or
C5, C6, C7, C10	4	470µF, 6.3V, 30mΩ low-ESR tantalum capacitors Kemet T510X477M006AS
C8	1	10µF, 6.3V ceramic capacitor Taiyo Yuden JMK325BJ106MN
C9	1	0.1µF ceramic capacitor (1206)
C11, C12	2	0.22µF ceramic capacitors (1206)
C13, C21, C22	0	Not installed
C14	1	470pF ceramic capacitor (1206)
C15	1	1µF ceramic capacitor (1206)
C17, C19, C23, C24, C25	5	4700pF ceramic capacitors (0805)

DESIGNATION	QTY	DESCRIPTION
C18	1	1000pF ceramic capacitor (0805)
D1	1	2A Schottky diode International Rectifier 10MQ040 or STMicroelectronics STPS2L25U
D2	1	100mA Schottky diode Central Semiconductor CMPSH-3
D3	1	200mA switching diode Central Semiconductor CMPD2838
J1	1	Scope-probe jack Berg Electronics 33JR135-1
JUA0-JUA4, JUB0-JUB4	10	2-pin headers
L1	1	1µH power inductor Sumida CEP125-1R0MC or Panasonic ETQP6F1R1BFA
N1	1	N-channel MOSFET (SO-8) International Rectifier IRF7811 or IRF 7811A

Pentium is a registered trademark of Intel Corp.
Quick-PWM is a trademark of Maxim Integrated Products.



MAX1717 Evaluation Kit

Component List (continued)

DESIGNATION	QTY	DESCRIPTION
N2, N3	2	N-channel MOSFETs (SO-8) International Rectifier IRF7805 or IRF 7811 or IRF 7811A
R1	1	20 Ω \pm 5% resistor (0805)
R2–R6, R9, R10, R22–R26	12	100k Ω \pm 5% resistors (0805)
R11	1	100 Ω \pm 5% resistor (0805)
R12	1	0.005 Ω \pm 1%, 1W resistor (2512) Dale WSL-2512-R005F
R13	1	10k Ω \pm 5% resistor (0805)
R14	1	120k Ω \pm 5% resistor (0805)
R15	1	20k Ω \pm 5% resistor (0805)
R16	1	300k Ω \pm 5% resistor (0805)
R17	1	200k Ω \pm 5% resistor (0805)
R18	1	24.9k Ω \pm 1% resistor (0805)
R19	1	27.4k Ω \pm 1% resistor (0805)
R20	1	2k Ω \pm 1% resistor (0805)
R21	1	160k Ω \pm 5% resistor (0805)
SW1	1	DIP-6 dip switch
U1	1	MAX1717EEG (24-pin QSOP)
None	10	Shunts
None	1	MAX1717 PC board
None	1	MAX1717 data sheet
None	1	MAX1717 EV kit data sheet

Recommended Equipment

- 7V to 24V, >20W power supply, battery, or notebook AC adapter
- DC bias power supply, 5V at 100mA
- Dummy load capable of sinking 14.1A
- Digital multimeter (DMM)
- 100MHz dual-trace oscilloscope

Quick Start

- 1) Ensure that the circuit is connected correctly to the supplies and dummy load prior to applying any power.
- 2) Set switches SW1-A ($\overline{\text{SHDN}}$), SW1-B (SKIP), and SW1-C (A/ $\overline{\text{B}}$) to the on position. This configures the EV kit for automatic pulse-skipping operation with the internal mux in A mode. The DAC code settings

Component Suppliers

SUPPLIER	PHONE	FAX
Central Semiconductor	516-435-1110	516-435-1824
Dale-Vishay	402-564-3131	402-563-6418
International Rectifier	310-322-3331	310-322-3332
Kemet	408-986-0424	408-986-1442
Panasonic	714-373-7939	714-373-7183
Sanyo	619-661-6322	619-661-1055
Sumida	847-956-0666	847-956-0702
Taiyo Yuden	408-573-4150	408-573-4159
Token	408-432-8020	408-434-0375

Note: Please indicate that you are using the MAX1717 when contacting these component suppliers.

D4–D0 are set to a 1.35V output for the A-mode configuration through installed jumpers JUA4 and JUA1, and to a 1.6V output for the B-mode configuration through installed jumpers JUB0, JUB1, JUB2, and JUB4.

- 3) Turn on the battery power before turning on the +5V bias power; otherwise, the output UVLO timer will time out and the FAULT latch will be set, disabling the regulator until +5V power is cycled or shutdown is toggled.
- 4) Observe the output with the DMM and/or oscilloscope. Look at the LX switching-node and MOSFET gate-drive signals while varying the load current.
- 5) Toggle the A/ $\overline{\text{B}}$ switch and observe the output voltage transition to the new 1.6V setting. **Note:** When driving A/ $\overline{\text{B}}$ with the dip switch, the transition may take longer than expected due to switch bounce.

Detailed Description

This 12A buck-regulator design is optimized for a 300kHz frequency and output voltage settings around 1.35V to 1.6V. At lower output voltages, transient response degrades slightly and efficiency worsens. At higher output voltages (approaching 2V), output ripple increases. At $V_{\text{OUT}} = 1.6\text{V}$, inductor ripple is approximately 30%, with a resulting pulse-skipping threshold at roughly $I_{\text{LOAD}} = 2\text{A}$.

Setting the Output Voltage

The MAX1717 uses an internal 5-bit DAC as well as a unique, proprietary, internal multiplexer that allows two

MAX1717 Evaluation Kit

Evaluates: MAX1717

different 5-bit codes to be entered using only five pins. The output voltage can be digitally set from 0.925V to 2V (Table 1). There are three different ways of setting the output voltage:

- **Drive the external VID0–VID4 inputs (no jumpers installed).** The output voltage can be set by driving VID0–VID4 with open-drain drivers or 3V/5V CMOS output logic levels (internal multiplexer must be in A-mode configuration A/B = high).
- **Install jumpers JUA0–JUA4** (A-mode configuration: SW1-C ON, A/B = high). When JUA0–JUA4 are not installed, the MAX1717's D0–D4 inputs are at logic 1 (connected to VCC). When JUA0–JUA4 are installed, D0–D4 inputs are at logic 0 (connected to GND). In the A-mode configuration, the output voltage can be changed during operation by installing and removing jumpers JUA0–JUA4. As shipped, the EV kit is configured for operation in A mode with jumpers JUA0–JUA4 set for a 1.35V output (Table 1).
- **Install jumpers JUB0–JUB4** (B-mode configuration: SW1-C OFF, A/B = low). When JUB0–JUB4 are not installed, a 100kΩ resistor is in series with each of the D0–D4 inputs, making them a logic 1 in B mode. When JUB0–JUB4 are installed, the 100kΩ resistors are shorted, making D0–D4 logic 0 in B mode. As shipped, the EV kit is configured for operation in B mode with jumpers JUB0–JUB4 set for 1.6V output (Table 1). While in the B-mode configuration, the output voltage cannot be changed. A/B, SHDN, or VBIAS must be cycled to reread the B-mode setting.

Refer to the MAX1717 data sheet for more information.

Voltage Positioning

The MAX1717 EV kit meets the Intel Mobile Pentium III CPU's transient voltage specification by using voltage positioning to minimize output capacitor requirements. The output voltage is initially set slightly high (1.25%), then allowed to regulate lower as the load current increases. R20 and R21 set the initial output voltage 23mV high, and R12 (5mΩ) causes the output voltage to drop with increasing load (60mV or about 4% of 1.6V at 12A).

Setting the output voltage high allows a larger step down when the output current suddenly increases. Regulating at the lower output voltage under load allows a larger step up when the output current suddenly decreases. Allowing a larger step size means that the output capacitance can be reduced and the capacitor's ESR can be increased. If voltage positioning is not used, one additional output capacitor is required to meet the same transient specification.

Table 1. MAX1717 Output Voltage Adjustment Settings

D4 JUA4 JUB4	D3 JUA3 JUB3	D2 JUA2 JUB2	D1 JUA1 JUB1	D0 JUA0 JUB0	OUTPUT VOLTAGE (V)
0	0	0	0	0	2
0	0	0	0	1	1.95
0	0	0	1	0	1.90
0	0	0	1	1	1.85
0	0	1	0	0	1.80
0	0	1	0	1	1.75
0	0	1	1	0	1.70
0	0	1	1	1	1.65
0	1	0	0	0	1.60
0	1	0	0	1	1.55
0	1	0	1	0	1.50
0	1	0	1	1	1.45
0	1	1	0	0	1.40
0	1	1	0	1	1.35
0	1	1	1	0	1.30
0	1	1	1	1	Shutdown
1	0	0	0	0	1.275
1	0	0	0	1	1.250
1	0	0	1	0	1.225
1	0	0	1	1	1.200
1	0	1	0	0	1.175
1	0	1	0	1	1.150
1	0	1	1	0	1.125
1	0	1	1	1	1.100
1	1	0	0	0	1.075
1	1	0	0	1	1.050
1	1	0	1	0	1.025
1	1	0	1	1	1.000
1	1	1	0	0	0.975
1	1	1	0	1	0.950
1	1	1	1	0	0.925
1	1	1	1	1	Shutdown

Note: Shunts installed on jumpers JUA0–JUA4, JUB0–JUB4 = logic 0.

An additional benefit of voltage positioning is reduced power consumption at high load currents. Because the output voltage is lower under load, the CPU draws less current. The result is lower power dissipation in the CPU, though some extra power is dissipated in R12. For

MAX1717 Evaluation Kit

a nominal 1.6V, 12A output, reducing the output voltage 2.6% (1.4% - 4%) gives an output voltage of 1.56V and an output current of 11.69A. Given these values, CPU power consumption is reduced from 19.2W to 18.23W. The additional power consumption of R12 is 0.68W, and the overall power savings is as follows:

$$19.2 - (18.23 + 0.68) = 0.3W$$

In effect, 1W of CPU dissipation is saved and the power supply dissipates much of the savings, but both the net savings and the transfer of dissipation away from the hot CPU are beneficial.

Efficiency Measurements and Effective Efficiency

Testing the power conversion efficiency (POUT/PIN) fairly and accurately requires more careful instrumentation than might be expected. One common error is to use inaccurate DMMs. Another is to use only one DMM and move it from one location to another to measure the various input/output voltages and currents. This second error usually results in changing the exact conditions applied to the circuit due to series resistance in the ammeters. It's best to use four 3-1/2 digit or better DMMs that have been recently calibrated and monitor VBATT, VOUT, IBATT, and ILOAD simultaneously. Connect the VBATT and VOUT meters directly across the input and output capacitors. Note that it's inaccurate to test efficiency at the remote VOUT and GND terminals, as this incorporates the parasitic resistance of the PC board output and ground buses in the measurement (a significant power loss).

Remember to include the power consumed by the +5V bias supply when making efficiency calculations:

$$\text{Efficiency} = \frac{V_{\text{OUT}} \times I_{\text{LOAD}}}{(V_{\text{BATT}} \times I_{\text{BATT}}) + (5V \times I_{\text{BIAS}})}$$

Efficiency performance is greatly impacted by the choice of MOSFET. The International Rectifier MOSFETs used in this kit were of leading-edge performance for 12A applications at the time the kit was designed. However, considering the rapid pace of MOSFET improvement, the latest offerings should be evaluated.

After obtaining the actual, accurate efficiency data, there is still some work remaining before an accurate assessment of a voltage-positioned circuit can be made. As discussed in the *Voltage Positioning* section, a voltage-positioned power supply can dissipate additional power while reducing overall system power consumption. For this reason, we use the concept of effective efficiency, which allows the direct comparison of a positioned and nonpositioned circuit's efficiency. Effective efficiency is defined as the efficiency required of a nonvoltage-positioned circuit to equal the total dissipation of a voltage-positioned circuit for a given CPU operating condition.

Calculate effective efficiency as follows:

- 1) Start with the efficiency data for the positioned circuit (V_{IN} , I_{IN} , V_{OUT} , I_{OUT}).
- 2) Calculate the load resistance for each V_{OUT} , I_{OUT} data point:

$$R_{\text{LOAD}} = V_{\text{OUT}} / I_{\text{OUT}}$$

- 3) Calculate the output current that would exist for each R_{LOAD} data point in a nonpositioned application:

$$I_{\text{NP}} = V_{\text{NP}} / R_{\text{LOAD}}$$

where $V_{\text{NP}} = 1.6V$ (in this example).

- 4) Calculate effective efficiency as:
Effective efficiency = $(V_{\text{NP}} \times I_{\text{NP}}) / (V_{\text{IN}} \times I_{\text{IN}})$ = calculated nonpositioned power output divided by the measured voltage-positioned power input.
- 5) Plot the efficiency data point at the current I_{NP} .

The effective efficiency of the voltage-positioned circuit will be less than that of the nonpositioned circuit at light loads (where the voltage-positioned output voltage is higher than the nonpositioned output voltage) and greater than that of the nonpositioned circuit at heavy loads (where the voltage-positioned output voltage is lower than the nonpositioned output voltage).

Dynamic Output Voltage Transition Experiment

Observe the output voltage transition between 1.35V and 1.6V by toggling the SW1-C (A/B) position between on and off. This EV kit is set to transition the output voltage at 3.75mV/ μ s. The speed of the transition can be altered by changing resistor R14 (120k Ω). You may observe longer-than-expected transitions due to switch bounce (SW1). To eliminate switch bounce, set SW1-C (A/B) to the off position, and drive the A/B pad with a function generator.

During the voltage transition, watch the inductor current by looking across R12 with a differential scope probe or

MAX1717 Evaluation Kit

Evaluates: MAX1717

by inserting a current probe in series with the inductor. Observe the low, well-controlled inductor current that accompanies the voltage transition. The same slew rate and controlled inductor current are used during shut-down and startup, resulting in well-controlled currents into and out of the battery (input source).

There are two other methods to create an output voltage transition. Select A mode by setting the A/B switch to the on position (SW1-C). Then either manually change the JUA0–JUA4 jumpers to a new VID code setting (Table 1), or remove all JUA0–JUA4 jumpers and drive the VID0–VID4 PC board test points external-ly to the desired code settings.

Load-Transient Experiment

One interesting experiment is to subject the output to large, fast load transients and observe the output with an oscilloscope. This requires careful instrumentation of the output using the supplied scope-probe jack. Accurate measurement of output ripple and load-transient response invariably requires that ground clip leads be completely avoided and that the probe hat be removed to expose the GND shield, so the probe can be plugged directly into the jack. Otherwise, EMI and noise pickup will corrupt the waveforms.

Most benchtop electronic loads intended for power-supply testing lack the ability to subject the DC-DC converter to ultra-fast load transients. Emulating the supply current di/dt at the CPU VCORE pins requires at least 10A/μs load transients. One easy method for generating such an abusive load transient is to solder a MOSFET, such as an MTP3055 or 12N05, directly across the scope-probe jack. Then drive its gate with a strong pulse generator at a low duty cycle (≤10%) to minimize heat stress in the MOSFET. Adjust the high-level output voltage of the pulse generator to vary the load current. Alternatively, control the load current with a load resistor in series with the MOSFET's drain, and drive the MOSFET fully on. Remember to include the expected on-resistance of the MOSFET in the load resistor calculation.

To determine the load current, you might expect to insert a meter in the load path, but this method is prohibited here by the need for low resistance and inductance in the path of the dummy load MOSFET. There are two

easy alternative methods of determining how much load current a particular pulse-generator amplitude is causing. The first and best is to observe the inductor current with a calibrated AC current probe, such as a Tektronix AM503. In the buck topology, the load current is equal to the average value of the inductor current. The second method is to measure the input current while using a static dummy load of the desired value. Then, connect the MOSFET dummy load at 100% duty momentarily, and adjust the gate-drive signal until the battery current rises to the appropriate level (the MOSFET load must be well heatsinked for this to work without causing smoke and flames).

Table 2. Switch SW1-A/SW1-B Functions (SHDN, SKIP)

SW1-A	SW1-B	CONNECTION	EFFECT
Off	X	SKP/ $\overline{\text{SDN}}$ connected to GND through R15 and R17.	Shutdown mode, $V_{\text{OUT}} = 0$.
On	On	SKP/ $\overline{\text{SDN}}$ connected to VCC through R15.	Output enabled. SKIP mode operation. Allows automatic PWM/PFM switchover for pulse skipping at light load for highest efficiency.
—	Off	SKP/ $\overline{\text{SDN}}$ connected to +2V through R15 and divider R16/R17.	Output enabled. Low-noise mode. Forced fixed-frequency PWM operation.

Table 3. Switch SW1-C Functions (A/B)

SW1-C	CONNECTION	MAX1717 OUTPUT
On	A/ $\overline{\text{B}}$ connected to VCC	Internal VID multiplexer set to A mode.
Off	A/ $\overline{\text{B}}$ connected to GND	Internal VID multiplexer set to B mode.

MAX1717 Evaluation Kit

Table 4. Jumpers JU3/JU4/JU5 Functions (Switching-Frequency Selection)

SHUNT LOCATION			TON PIN	FREQUENCY (kHz)
JU3	JU4	JU5		
Installed	Not Installed	Not Installed	Connected to V _{CC}	200
Not Installed	Installed	Not Installed	Connected to REF	550
Not Installed	Not Installed	Installed	Connected to GND	1000
Not Installed	Not Installed	Not Installed	Floating	300

IMPORTANT: Don't change the operating frequency without first recalculating component values. The frequency has a significant effect on the peak current-limit level, MOSFET heating, preferred inductor value, PFM/PWM switchover point, output noise, efficiency, and other critical parameters.

Table 5. Jumper JU6 Functions (Fixed/Adjustable Current-Limit Selection)

SHUNT POSITION	ILIM PIN	CURRENT-LIMIT THRESHOLD
On	Connected to V _{CC}	100mV
Off	Connected to midpoint of external resistor-divider R18/R19. Refer to the <i>Pin Description</i> in the MAX1717 data sheet for more information (see <i>Current Limit</i> section).	Adjustable from 50mV to 300mV.

Table 6. Troubleshooting Guide

SYMPTOM	POSSIBLE PROBLEM	SOLUTION
Circuit won't start when power is applied.	Power-supply sequencing: +5V bias supply was applied first.	Cycle SW1-A ($\overline{\text{SHDN}}$).
Circuit won't start when RESET is pressed, +5V bias supply cycled.	Output overvoltage due to shorted high-side MOSFET.	Replace the MOSFET.
	Output overvoltage due to load recovery above 2.25V.	Reduce the inductor value, raise the switching frequency, or add more output capacitance.
	Output overload condition.	Remove excessive load.
	Broken connection, bad MOSFET, or other catastrophic problem.	Troubleshoot the power stage. Are the DH and DL gate-drive signals present? Is the 2V V _{REF} present?
On-time pulses are erratic or exhibit unexpected changes in period.	VBATT power source has poor impedance characteristic.	Add a bulk electrolytic bypass capacitor across the benchtop power supply, or substitute a real battery.
Excessive EMI, poor efficiency at high input voltages.	Gate-drain capacitance of N2 is causing shoot-through cross-conduction.	Observe the gate-source voltage of N2 during the low-to-high LX node transition (this requires careful instrumentation). Is the gate voltage being pulled above 1.5V, causing N2 to turn on? Use a smaller low-side MOSFET or add a BST resistor (R7).
Poor efficiency at high input voltages, N1 gets hot.	N1 has excessive gate capacitance.	Use a smaller high-side MOSFET or add more heatsinking.

MAX1717 Evaluation Kit

Evaluates: MAX1717

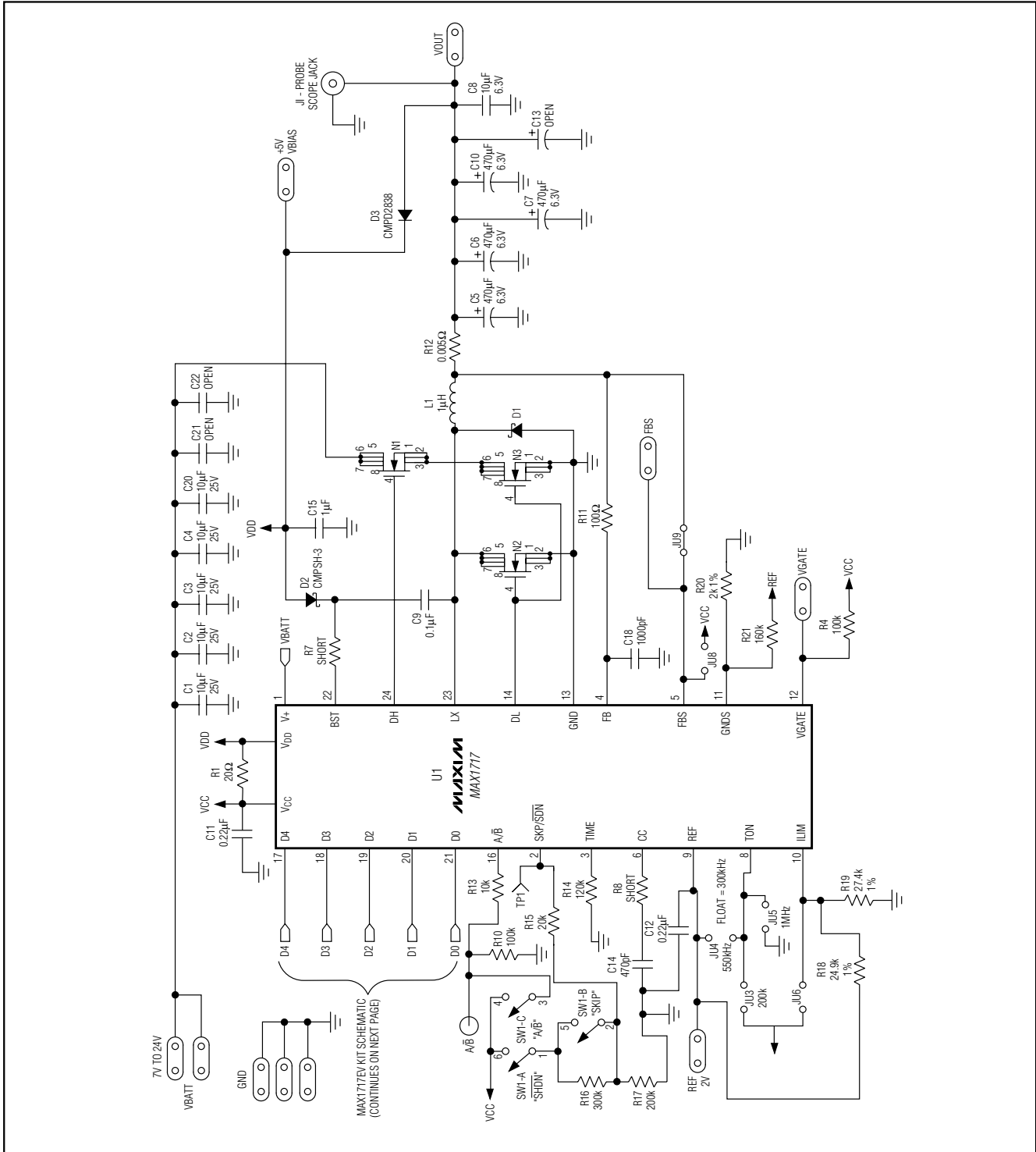

Figure 1. MAX1717 EV Kit Schematic

MAX1717 Evaluation Kit

Evaluates: MAX1717

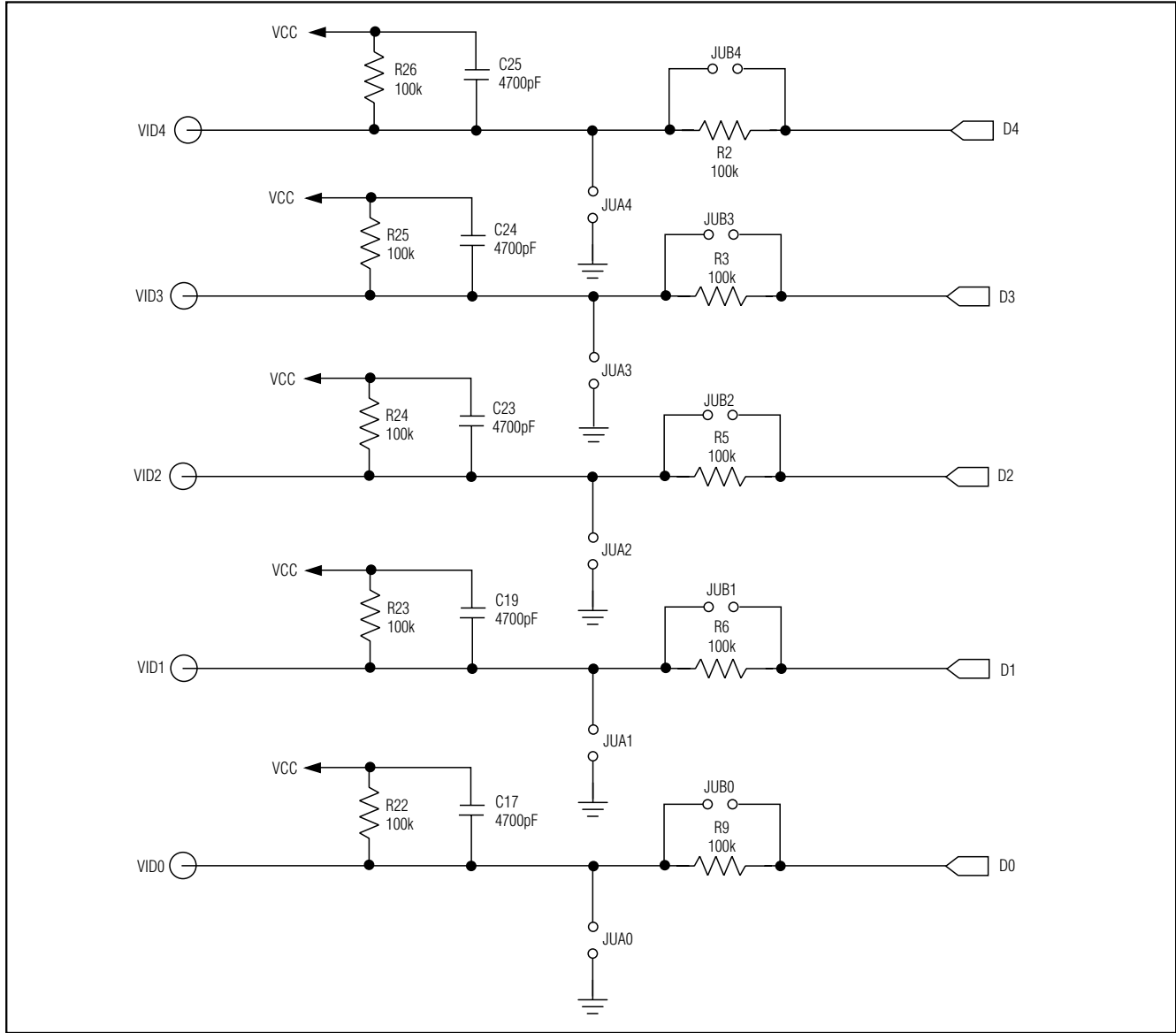

Figure 1. MAX1717 EV Kit Schematic (continued)

MAX1717 Evaluation Kit

Evaluates: MAX1717

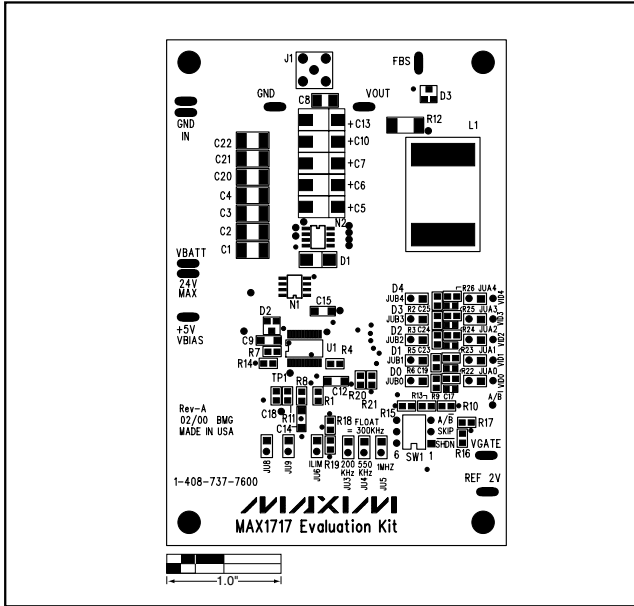

Figure 2. MAX1717 EV Kit Component Placement Guide—Component Side

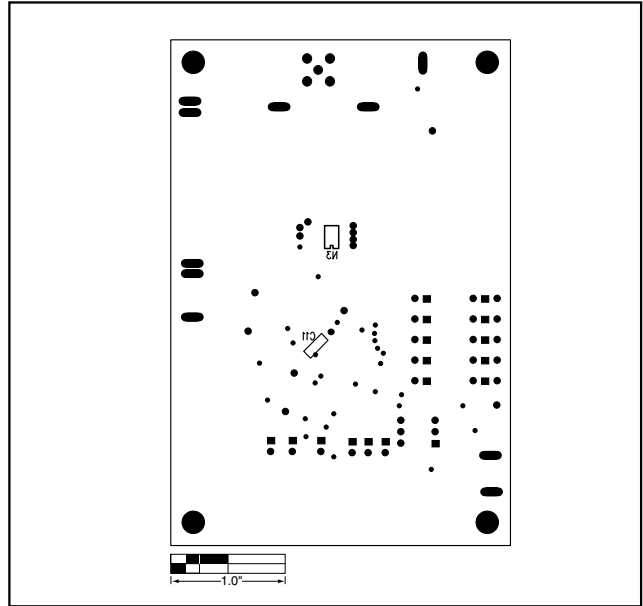

Figure 3. MAX1717 EV Kit Component Placement Guide—Solder Side

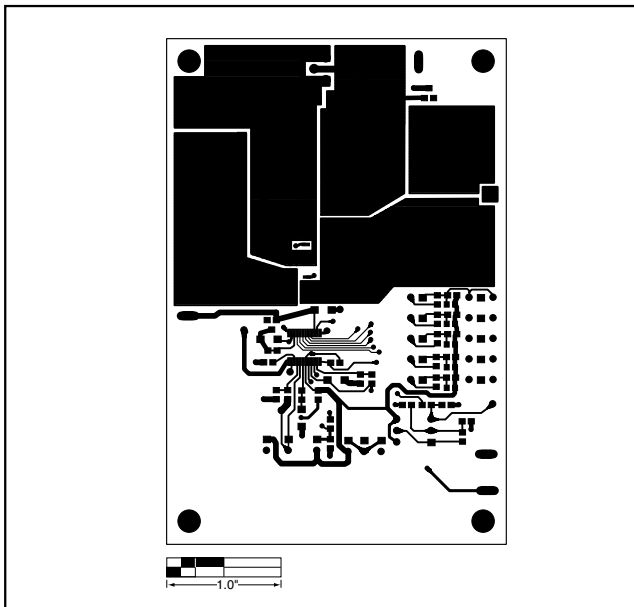

Figure 4. MAX1717 EV Kit PC Board Layout—Component Side

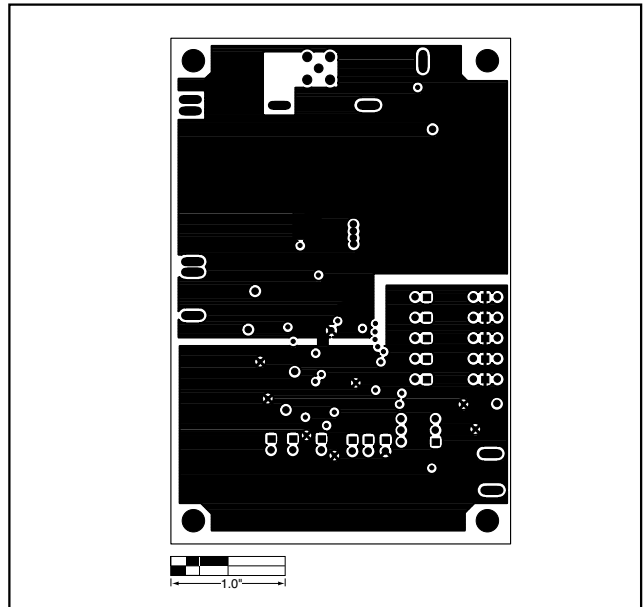

Figure 5. MAX1717 EV Kit PC Board Layout—Ground Plane (Layer 2)

MAX1717 Evaluation Kit

Evaluates: MAX1717

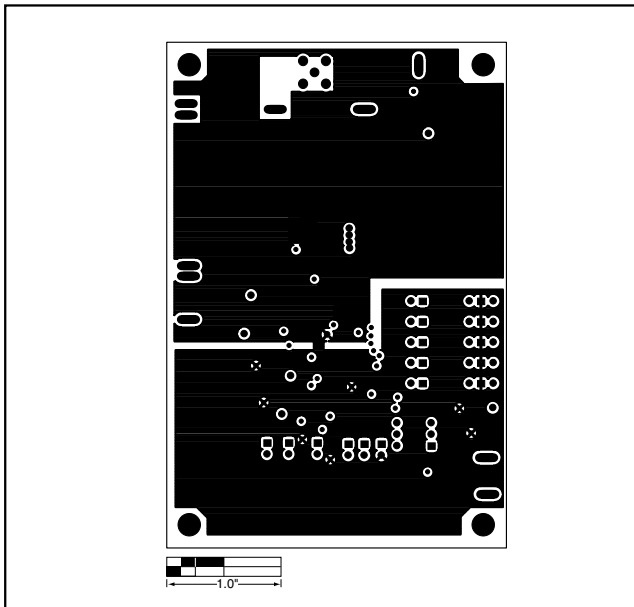

Figure 6. MAX1717 EV Kit PC Board Layout—Ground Plane (Layer 3)

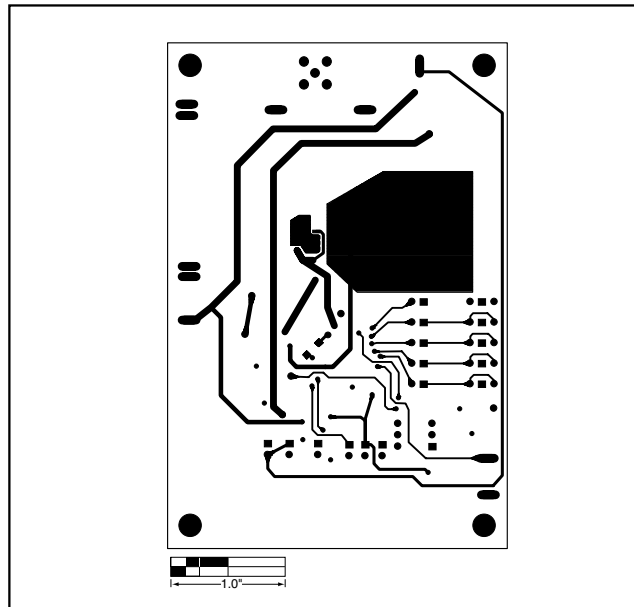

Figure 7. MAX1717 EV Kit PC Board Layout—Solder Side

MAX1717 Evaluation Kit

NOTES

Evaluates: MAX1717

MAX1717 Evaluation Kit

Evaluates: MAX1717

NOTES

Maxim cannot assume responsibility for use of any circuitry other than circuitry entirely embodied in a Maxim product. No circuit patent licenses are implied. Maxim reserves the right to change the circuitry and specifications without notice at any time.

12 _____ **Maxim Integrated Products, 120 San Gabriel Drive, Sunnyvale, CA 94086 408-737-7600**

© 2000 Maxim Integrated Products

Printed USA

MAXIM is a registered trademark of Maxim Integrated Products.