



# MAX1707 Evaluation Kit/Evaluation System

## General Description

The MAX1707 evaluation system (EV system) includes a MAX1707 evaluation kit (EV kit) and a Maxim command module (CMODUSB).

The MAX1707 EV kit is an assembled and tested PC board that demonstrates the capabilities of the MAX1707 light-management IC. The EV kit includes four main display backlight LEDs, an RGB indicator LED, and a white LED camera flash that can all be driven simultaneously by the MAX1707. The EV kit also includes PC software that allows a user to evaluate every feature of the MAX1707 using a graphical user interface (GUI).

The CMODUSB board connects to a PC's USB port and allows the transfer of I<sup>2</sup>C\* commands to the MAX1707 EV kit.

## Component Suppliers

SUPPLIER	PHONE	WEBSITE
Lumileds	877-298-9455	www.lumileds.com
Nichia	248-352-6575	www.nichia.com
Stanley Electric	800-533-5231	www.stanley-components.com
TDK	847-803-6100	www.component.tdk.com

**Note:** Indicate you are using the MAX1707 when contacting these component suppliers.

## Features

- ◆ Proven PC Board Layout
- ◆ Windows® 98/2000/XP-Compatible Evaluation Software
- ◆ White LED Camera Flash, RGB Indicator LED, and Four Backlight LEDs
- ◆ Pushbutton for Evaluating Strobe Function
- ◆ Terminals for Access to I<sup>2</sup>C Interface Lines
- ◆ Fully Assembled and Tested

## Ordering Information

PART	TYPE	INTERFACE TYPE
MAX1707EVKIT	EV kit	User-supplied
MAX1707EVCMODU	EV system	CMODUSB board

**Note:** The MAX1707 EV kit software is included with the MAX1707 EV kit but is designed for use with the complete EV system. The EV system includes both the Maxim CMODUSB and the EV kit. If the Windows software will not be used, the EV kit board can be purchased without the CMODUSB.

## Component List

### MAX1707EVKIT

DESIGNATION	QTY	DESCRIPTION
C1, C2	2	1 $\mu$ F $\pm$ 20%, 6.3V X5R capacitors (0402) TDK C1005X5R0J105M
C3	1	4.7 $\mu$ F $\pm$ 10%, 6.3V X5R capacitor (0603) TDK C1608X5R0J475K
C4	1	0.1 $\mu$ F $\pm$ 10%, 10V X5R capacitor (0402) TDK C1005X5R1A104K
C5	1	10 $\mu$ F $\pm$ 20%, 6.3V X5R capacitor (0805) TDK C2012X5R0J106M

\*Purchase of I<sup>2</sup>C components from Maxim Integrated Products, Inc., or one of its sublicensed Associated Companies, conveys a license under the Philips I<sup>2</sup>C Patent Rights to use these components in an I<sup>2</sup>C system, provided that the system conforms to the I<sup>2</sup>C Standard Specification as defined by Philips.

DESIGNATION	QTY	DESCRIPTION
D1–D4	4	White LEDs Nichia NSCW215
D5	1	RGB LED Stanley FRGB1304B Lumex SML-LX2832SISUGSBC
D6	1	Flash LED Lumileds LXCL-PWF1
D7	0	Not installed Nichia NASW031
J1	1	2 x 10 right-angle receptacle (0.1in)
JU1	1	2-pin header
R1, R2	2	3.9k $\Omega$ $\pm$ 5% resistors (0402)
R3	1	100k $\Omega$ $\pm$ 5% resistor (0402)
SW1	1	Momentary pushbutton switch Panasonic EVQ-PHP03T

Windows is a registered trademark of Microsoft Corp.

Evaluate: MAX1707



# MAX1707 Evaluation Kit/Evaluation System

## Component List (continued) MAX1707 EV Kit

DESIGNATION	QTY	DESCRIPTION
U1	1	LED driver MAX1707ETG (24-pin thin QFN 4mm x 4mm)
—	1	Shunts
—	1	MAX1707 evaluation kit software, CD-ROM

## MAX1707 EV System

DESIGNATION	QTY	DESCRIPTION
MAX1707EVKIT	1	MAX1707 EV kit
CMODUSB	1	Maxim command module

## MAX1707EVKIT Files

PROGRAM	DESCRIPTION
INSTALL.EXE	Installs the EV kit files on your computer
MAX1707.EXE	Application program
HELPIFILE.HTM	MAX1707 EV kit help file
UNINST.INI	Uninstalls the EV kit software
FTD2XX.INF	USB device driver file
Troubleshooting_USB.PDF	USB device driver help file

## Quick Start

### Recommended Equipment

- The Maxim MAX1707EVCMODU evaluation system:  
MAX1707EVKIT  
Maxim command module (CMODUSB)  
USB cable (included with CMODUSB)
- One power supply  
2.7V or higher (up to 5.5V) at 2A
- A user-supplied Windows 98/2000/XP PC with an unused USB port.

### Procedure

**Do not enable the power supply until all connections are made:**

- Place shunt on pins 1 and 2 of JU1 (selects VDD as supply for IN).
- Connect the MAX1707 EV kit's 20-pin female connector (J1) to the CMODUSB's 20-pin male connector (P3).

- Disable the I<sup>2</sup>C pullup resistors on the CMODUSB board by setting the DIP switch (SW1 on the CMODUSB board) to the off position.
- Install the MAX1707 EV kit software on your PC by running the INSTALL.EXE program. The files can be obtained from the Maxim website or the included CD. The program files are copied and icons are created for them in the Windows **Start** menu.
- Connect the USB cable between the PC's USB port and the CMODUSB's USB connector (P2). A **New Hardware Found** window should pop up. If you do not see a window similar to the one described above after 30 seconds, try removing the USB cable from the CMODUSB and reconnecting it again. Administrator privileges are required to install the USB device driver on Windows 2000 and Windows XP.
- Follow the directions of the **Add New Hardware** wizard to install the USB device driver. Choose the "Search for the best driver for your device" option. Specify the location of the device driver to be C:\MAX1707 (or the directory chosen during installation) using the **Browse** button.
- Connect the 2.7V power supply (up to 5.5V supported) between the MAX1707 EV kit's IN and GND pads.
- Enable the power supply.
- Start the MAX1707 EV kit software by double-clicking its icon in the **Start** menu.

## Detailed Description of Software

To start the software, double-click the MAX1707 EV kit icon that is created during installation. The graphical user interface shown in Figure 1 will appear. The user must wait approximately two seconds while the MAX1707 EV kit software connects to the CMODUSB.

### Brightness Controls

The **Brightness Controls** group box contains checkboxes and scrollbars that allow the MAX1707 on the EV kit to control the amount of current through each LED. The checkboxes on the left side of the application window allow the different LEDs to be enabled or disabled while the scrollbars allow the current through each LED to be adjusted.

Note that the strobe function cannot be enabled or disabled using the EV kit software. The only available control is the **Strobe** scrollbar that adjusts the current through the white LED camera flash. To enable the white LED camera flash using the strobe function, press the momentary pushbutton (SW1) on the MAX1707 EV kit. When the strobe current is at high levels, do not hold the

# MAX1707 Evaluation Kit/Evaluation System

momentary pushbutton continuously; this may damage the white LED camera flash.

For safety reasons, when the white LED camera flash is enabled using the **Flash** checkbox in the application window, it automatically disables after a short amount of time. This amount of time can be selected in the **Options|Set Flash LED On Time** menu item.

### Miscellaneous Controls

The **Miscellaneous Controls** group box contains a checkbox to enable or disable the LED temperature derating function, as well as a pulldown menu to select the RGB ramp rate for the MAX1707.

### Demo Mode

The MAX1707 EV kit supports a demo mode that is enabled when the user selects the **Options|Demo Mode** menu item. Demo mode does the following:

- Smoothly ramps up and down the main backlights.

- Smoothly cycles through all colors on the RGB LED.
- Quickly enables and disables the white LED camera flash.

### Detailed Description of Hardware MAX1707EVCMODU Evaluation System

The MAX1707 EV system (MAX1707EVCMODU) is a complete light-management system consisting of a MAX1707 evaluation kit (EV kit) and the Maxim command module (CMODUSB).

### CMODUSB

The CMODUSB is a Maxim command module that provides an I<sup>2</sup>C interface bus to demonstrate various Maxim devices. Maxim reserves the right to change the implementation of this module at any time with no advance notice.

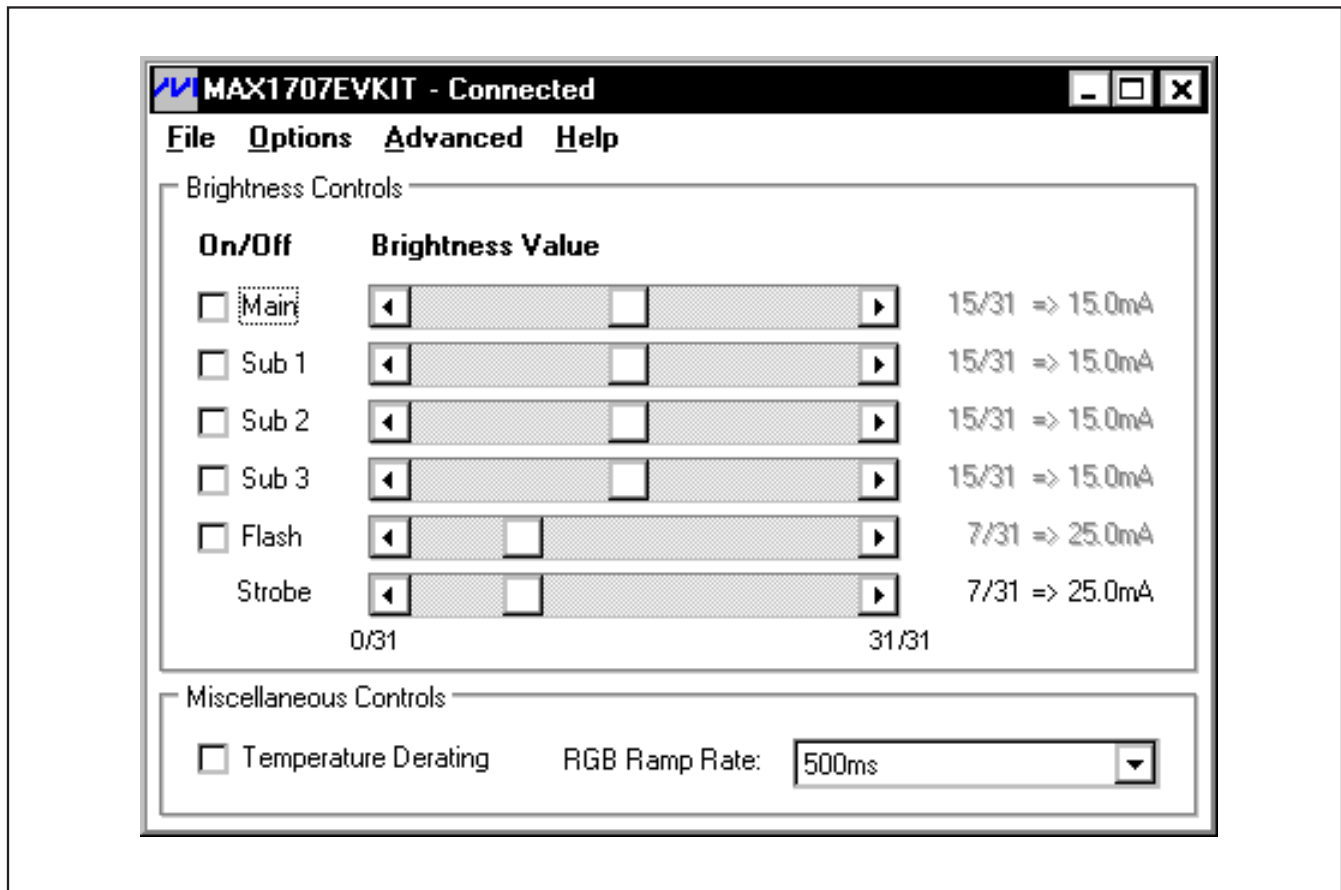

Figure 1. MAX1707 EV Kit Software

# MAX1707 Evaluation Kit/Evaluation System

## MAX1707 EV Kit

The MAX1707 EV kit board provides a proven layout for evaluating the MAX1707 light-management IC and can be obtained separately without the CMODUSB.

The EV kit includes four main display backlight LEDs (D1 to D4), an RGB indicator LED (D5), and a white LED camera flash (D6). These LEDs can be enabled and current through each LED can be controlled using the MAX1707 EV kit software (see the *Detailed Description of Software* section). The momentary push-button (SW1) connects to the  $\overline{\text{STB}}$  pin on the MAX1707 and allows the LED flash drivers to be evaluated without the need for the MAX1707 EV kit software. However, to control the current through the white LED camera flash using the strobe function, the EV kit software is required.

The MAX1707 EV kit also includes PC board landing pads (D7) to evaluate a different white LED camera-flash device than the one included on the EV kit.

The SCK and SDA pads on the MAX1707 EV kit provide access to the I<sup>2</sup>C interface and allow the evaluation of the MAX1707 without the CMODUSB. Note that 3.9k $\Omega$  pullup resistors for the I<sup>2</sup>C interface are included on the EV kit board.

## Jumper Selection Tables

Table 1 explains the functionality of the jumper on the MAX1707 EV kit.

**Table 1. Select IN Source**

JUMPER	SHUNT POSITION	DESCRIPTION
JU1	Short*	Connect VDD to IN.
	Open	Disconnect VDD from IN.

\*Default configuration.

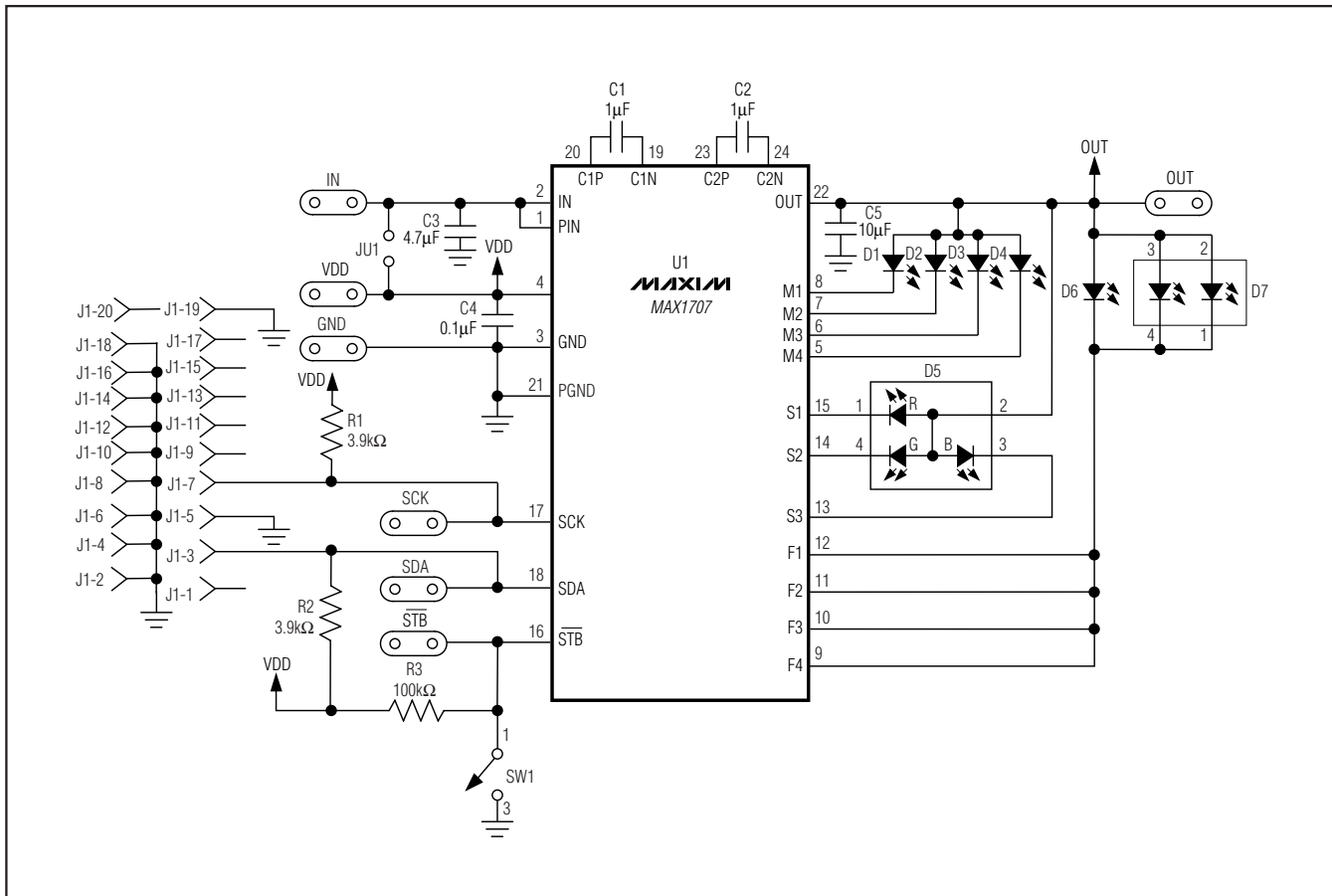

Figure 2. MAX1707 EV Kit Schematic

# MAX1707 Evaluation Kit/Evaluation System

Evaluate: MAX1707

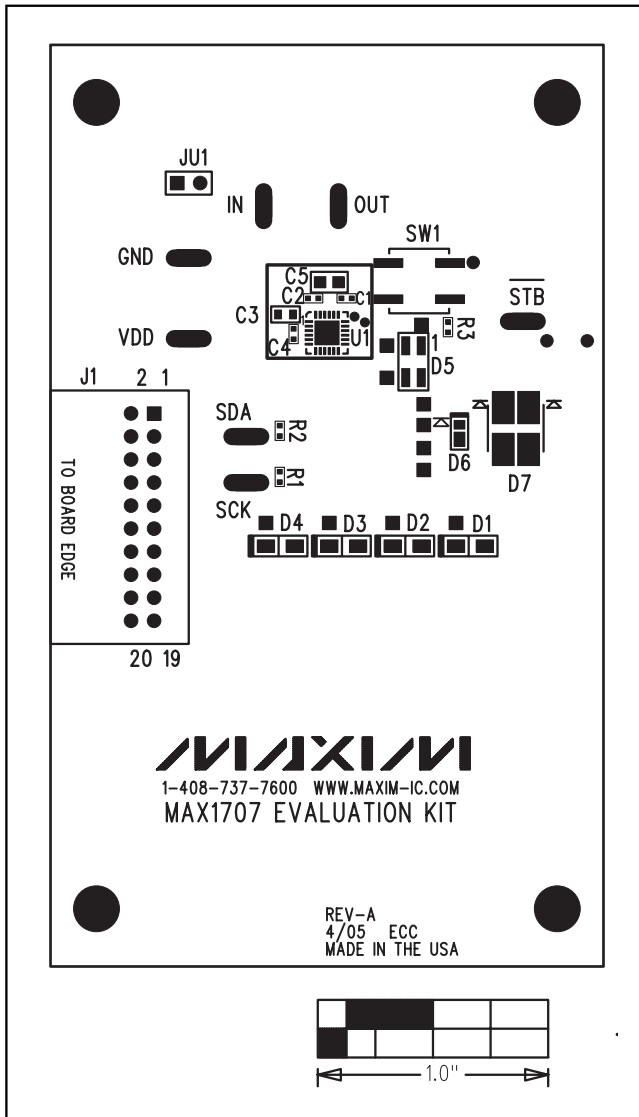

Figure 3. MAX1707 EV Kit Component Placement Guide—Component Side

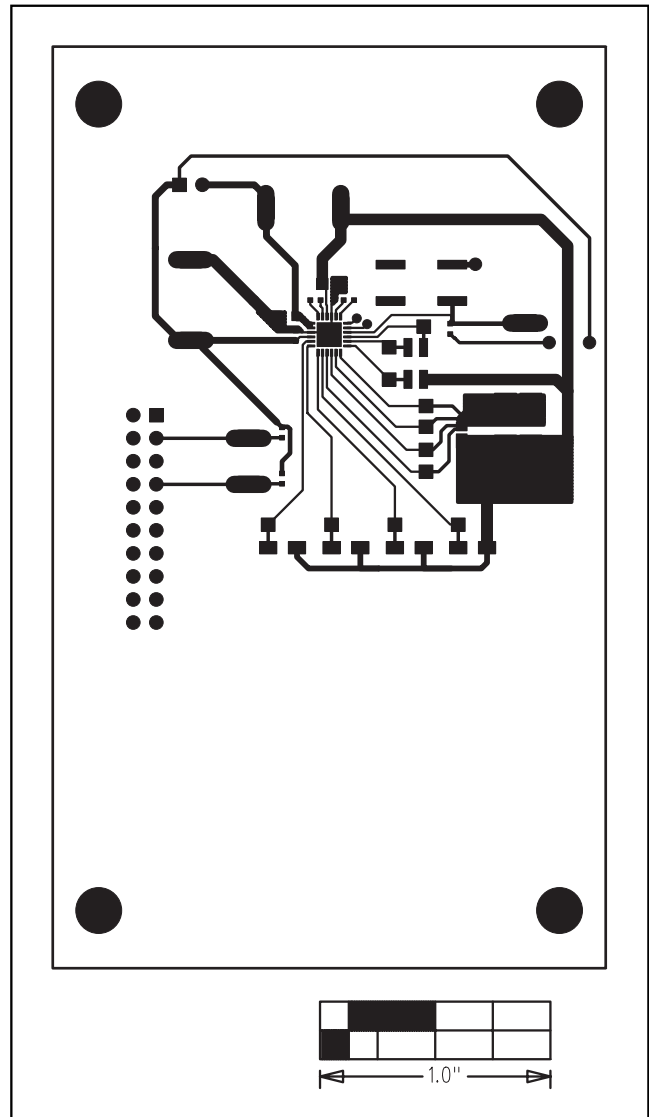

Figure 4. MAX1707 EV Kit PC Board Layout—Component Side

# MAX1707 Evaluation Kit/Evaluation System

Evaluate: MAX1707

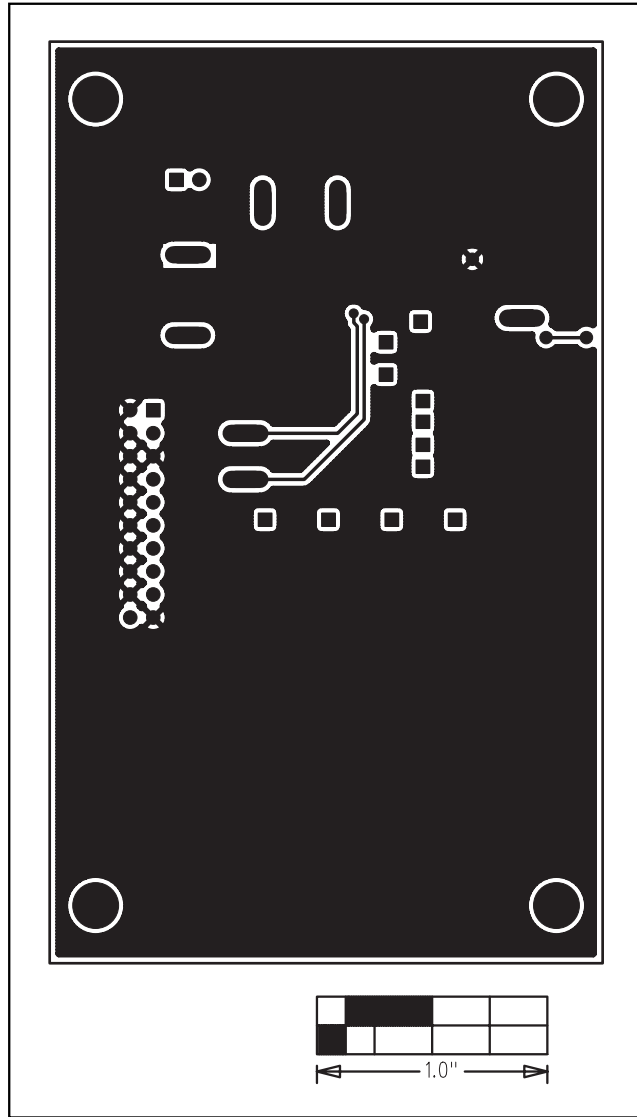

Figure 5. MAX1707 EV Kit PC Board Layout—Solder Side

Maxim cannot assume responsibility for use of any circuitry other than circuitry entirely embodied in a Maxim product. No circuit patent licenses are implied. Maxim reserves the right to change the circuitry and specifications without notice at any time.

6 \_\_\_\_\_ **Maxim Integrated Products, 120 San Gabriel Drive, Sunnyvale, CA 94086 408-737-7600**

© 2005 Maxim Integrated Products

Printed USA

**MAXIM** is a registered trademark of Maxim Integrated Products, Inc.