



30mA Inverting Charge Pump in SOT23 for EMI-Sensitive Automotive Applications

MAX16945

General Description

The MAX16945 ultra-small, monolithic, CMOS charge-pump voltage inverter accepts an input voltage ranging from +1.4V to +5.5V. This device features an ultra-low 12Ω output resistance, permitting loads of up to 30mA at +105°C with maximum efficiency. The MAX16945 operates at a frequency of 125kHz, allowing use of small external components. Its small external components, micropower shutdown mode, and wide temperature range make this device ideal for both automotive and industrial applications.

Oscillator control circuitry and four power MOSFET switches are included on-chip. The MAX16945 comes in a 6-pin SOT23 package and operates over -40°C to +105°C.

Applications

Automotive and Industrial Equipment
 Small LCD Panels
 Negative Supply from +5V or +3.3V Logic Supplies
 GaAsFET Bias Supplies
 Handy-Terminals, PDAs

Typical Operating Circuit

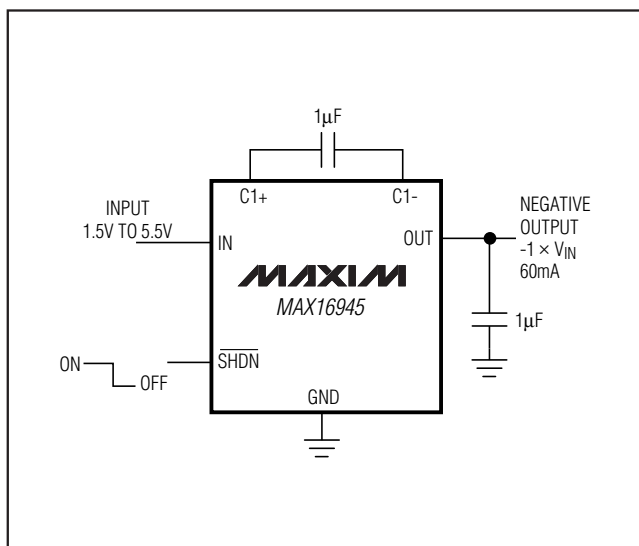

Features

- ◆ +1.4V to +5.5V Input Voltage Range
- ◆ 30mA Guaranteed Output Current at +105°C
- ◆ Slew-Rate Limited to Reduce EMI
- ◆ 0.1μA Logic-Controlled Shutdown
- ◆ Low 12Ω Output Resistance
- ◆ Startup Current Limited
- ◆ 6-Pin SOT23 Package
- ◆ AEC-Q100 Qualified

Ordering Information

PART	TEMP RANGE	PIN-PACKAGE
MAX16945TGUT#	-40°C to +105°C	6 SOT23
MAX16945TGUT/V+	-40°C to +105°C	6 SOT23

Denotes a RoHS-compliant device that may include lead that is exempt under RoHS requirements.

/V denotes an automotive qualified part.

+ Denotes a lead(Pb)-free/RoHS-compliant package.

Note: The MAX16945 requires a special solder temperature profile described in the Absolute Maximum Ratings section.

Pin Configuration

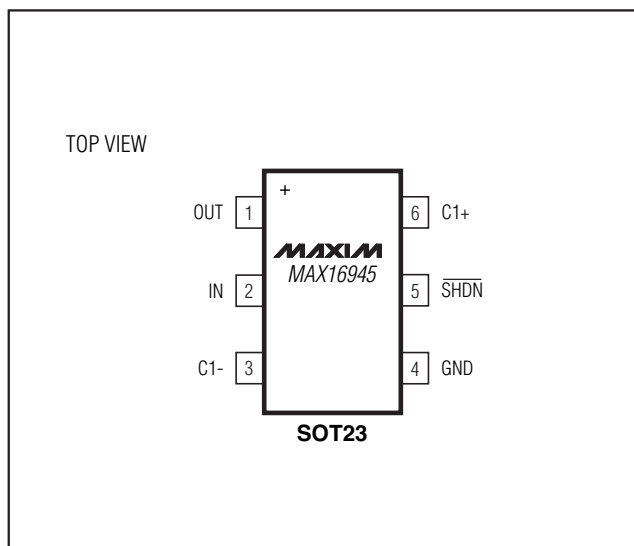

30mA Inverting Charge Pump in SOT23 for EMI-Sensitive Automotive Applications

ABSOLUTE MAXIMUM RATINGS

IN to GND	-0.3V to +6V
C1+, $\overline{\text{SHDN}}$ to GND	0.3V to ($V_{\text{IN}} + 0.3\text{V}$)
C1- to GND	($V_{\text{OUT}} - 0.3\text{V}$) to +0.3V
OUT to GND	+0.3V to -6V
OUT Output Current	90mA
OUT Short Circuit to GND	Indefinite
Continuous Power Dissipation ($T_{\text{A}} = +70^{\circ}\text{C}$)	
6-Pin SOT23 (derate 7.4mW/ $^{\circ}\text{C}$ above +70 $^{\circ}\text{C}$) (Note 1)	595mW

Junction-to-Case Thermal Resistance (θ_{JC}) (Note 1)	
6-Pin SOT23	39 $^{\circ}\text{C}/\text{W}$
Junction-to-Ambient Thermal Resistance (θ_{JA}) (Note 1)	
6-Pin SOT23	134 $^{\circ}\text{C}/\text{W}$
Operating Temperature Range	-40 $^{\circ}\text{C}$ to +105 $^{\circ}\text{C}$
Junction Temperature	+150 $^{\circ}\text{C}$
Storage Temperature Range	-65 $^{\circ}\text{C}$ to +150 $^{\circ}\text{C}$
Lead Temperature	(Note 2)

Note 1: Package thermal resistances were obtained using the method described in JEDEC specification JESD51-7, using a four-layer board. For detailed information on package thermal considerations, refer to www.maxim-ic.com/thermal-tutorial.

Note 2: This device is constructed using a unique set of packaging techniques that impose a limit on the thermal profile the device can be exposed to during board-level solder attach and rework. Maxim recommends the use of the solder profiles recommended in the industry-standard specification, JEDEC 020A, paragraph 7.6, Table 3 for IR/VPF and Convection reflow processes. Preheating, per this standard, is required. Hand or wave soldering is not recommended.

Stresses beyond those listed under "Absolute Maximum Ratings" may cause permanent damage to the device. These are stress ratings only, and functional operation of the device at these or any other conditions beyond those indicated in the operational sections of the specifications is not implied. Exposure to absolute maximum rating conditions for extended periods may affect device reliability.

ELECTRICAL CHARACTERISTICS

(Circuit of Figure 1, $C1 = C2 = 2.2\mu\text{F}$, $V_{\text{IN}} = \overline{\text{VSHDN}} = +5\text{V}$, $V_{\text{GND}} = 0$, $T_{\text{A}} = 0^{\circ}\text{C}$ to +105 $^{\circ}\text{C}$, unless otherwise noted. Typical values are at $T_{\text{A}} = +25^{\circ}\text{C}$.)

PARAMETER	CONDITIONS	MIN	TYP	MAX	UNITS	
Supply Voltage Range	$R_{\text{L}} = 5\text{k}\Omega$	$T_{\text{A}} = +25^{\circ}\text{C}$	1.4	5.5	V	
		$T_{\text{A}} = 0^{\circ}\text{C}$ to +105 $^{\circ}\text{C}$	1.5	5.5		
Quiescent Supply Current	$T_{\text{A}} = +25^{\circ}\text{C}$ (Note 3)		950	1700	μA	
Shutdown Supply Current	$\overline{\text{VSHDN}} = 0$	$T_{\text{A}} = +25^{\circ}\text{C}$	0.002	1	μA	
		$T_{\text{A}} = 0^{\circ}\text{C}$ to +105 $^{\circ}\text{C}$		0.03		
Short-Circuit Current	Output shorted to ground, $T_{\text{A}} = +25^{\circ}\text{C}$		170		mA	
Oscillator Frequency	$T_{\text{A}} = +25^{\circ}\text{C}$	70	125	180	kHz	
Voltage Conversion Efficiency	$I_{\text{OUT}} = 0$, $T_{\text{A}} = +25^{\circ}\text{C}$	99	99.9		%	
Output Resistance	$I_{\text{OUT}} = 30\text{mA}$ (Note 4)	$T_{\text{A}} = +25^{\circ}\text{C}$	12	25	Ω	
		$T_{\text{A}} = 0^{\circ}\text{C}$ to +105 $^{\circ}\text{C}$		36		
OUT-to-GND Shutdown Resistance	$\overline{\text{VSHDN}} = 0$, OUT is internally pulled to GND in shutdown		3	8.5	Ω	
$\overline{\text{SHDN}}$ Input Logic-High	$2.5\text{V} \leq V_{\text{IN}} \leq 5.5\text{V}$	2.0			V	
	$V_{\text{IN(MIN)}} \leq V_{\text{IN}} \leq 2.5\text{V}$	$V_{\text{IN}} - 0.2$				
$\overline{\text{SHDN}}$ Input Logic-Low	$2.5\text{V} \leq V_{\text{IN}} \leq 5.5\text{V}$			0.6	V	
	$V_{\text{IN(MIN)}} \leq V_{\text{IN}} \leq 2.5\text{V}$			0.2		
$\overline{\text{SHDN}}$ Bias Current	$\overline{\text{SHDN}} = \text{GND}$ or IN	$T_{\text{A}} = +25^{\circ}\text{C}$	-100	+0.05	+100	nA
		$T_{\text{A}} = 0^{\circ}\text{C}$ to +105 $^{\circ}\text{C}$		10		
Wake-Up Time from Shutdown	$I_{\text{OUT}} = 15\text{mA}$		100		μs	

30mA Inverting Charge Pump in SOT23 for EMI-Sensitive Automotive Applications

MAX16945

ELECTRICAL CHARACTERISTICS

(Circuit of Figure 1, $C_1 = C_2 = 2.2\mu\text{F}$, $V_{\text{IN}} = V_{\text{SHDN}} = +5\text{V}$, $V_{\text{GND}} = 0$, $T_A = 0^\circ\text{C}$ to $+105^\circ\text{C}$, unless otherwise noted. Typical values are at $T_A = +25^\circ\text{C}$.)

PARAMETER	CONDITIONS	MIN	TYP	MAX	UNITS
Supply Voltage Range	$R_L = 5\text{k}\Omega$	1.6		5.5	V
Output Current	Continuous, long-term			60	mARMS
Quiescent Supply Current	(Note 3)			1800	μA
Oscillator Frequency		60	125	200	kHz
Output Resistance	$I_{\text{OUT}} = 30\text{mA}$ (Note 5)			36	Ω
OUT-to-GND Shutdown Resistance	$V_{\text{SHDN}} = 0$, OUT is internally pulled to GND in shutdown			8.5	Ω
$\overline{\text{SHDN}}$ Input Logic-High	$2.5\text{V} \leq V_{\text{IN}} \leq 5.5\text{V}$	2.1			V
	$V_{\text{IN(MIN)}} \leq V_{\text{IN}} \leq 2.5\text{V}$	$V_{\text{IN}} - 0.2$			
$\overline{\text{SHDN}}$ Input Logic-Low	$2.5\text{V} \leq V_{\text{IN}} \leq 5.5\text{V}$			0.6	V
	$V_{\text{IN(MIN)}} \leq V_{\text{IN}} \leq 2.5\text{V}$			0.2	

Note 3: The MAX16945 may draw high supply current during startup, up to the minimum operating supply voltage. To guarantee proper startup, the input supply must be capable of delivering 90mA more than the maximum load current.

Note 4: Output resistance is guaranteed with capacitor ESR of 0.3Ω or less.

Note 5: All specifications from -40°C to $+105^\circ\text{C}$ are guaranteed by design, not production tested.

Typical Operating Characteristics

(Circuit of Figure 1, $C_1 = C_2 = 2.2\mu\text{F}$, $V_{\text{IN}} = V_{\text{SHDN}} = +5\text{V}$, $V_{\text{GND}} = 0$, $T_A = +25^\circ\text{C}$, unless otherwise noted.)

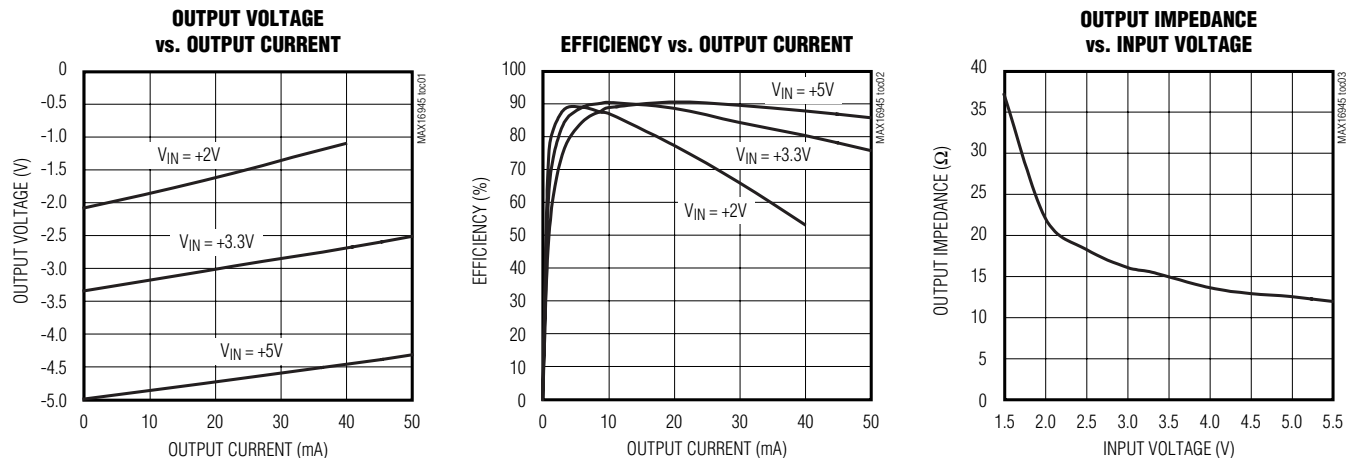

30mA Inverting Charge Pump in SOT23 for EMI-Sensitive Automotive Applications

Typical Operating Characteristics (continued)

(Circuit of Figure 1, C1 = C2 = 2.2μF, V_{IN} = V_{SHDN} = +5V, V_{GND} = 0, T_A = +25°C, unless otherwise noted.)

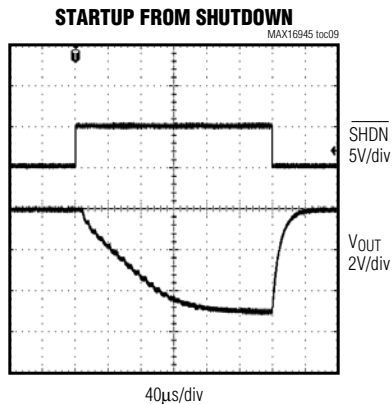
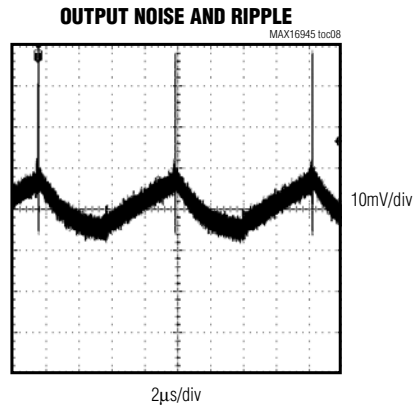
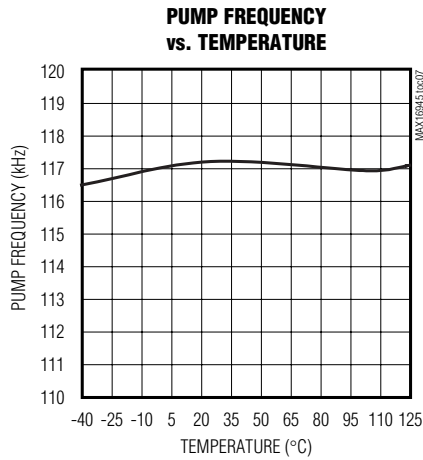
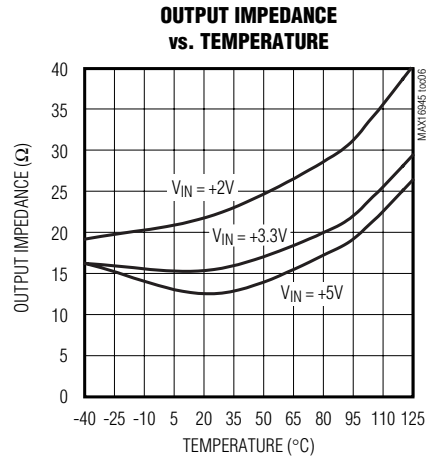
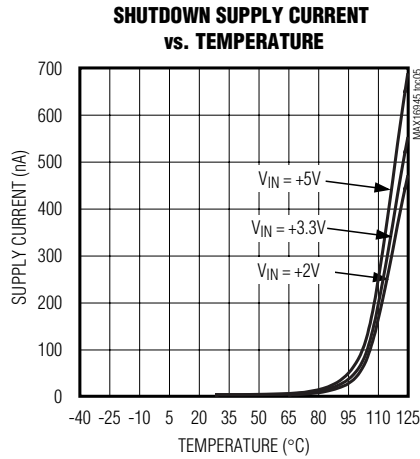
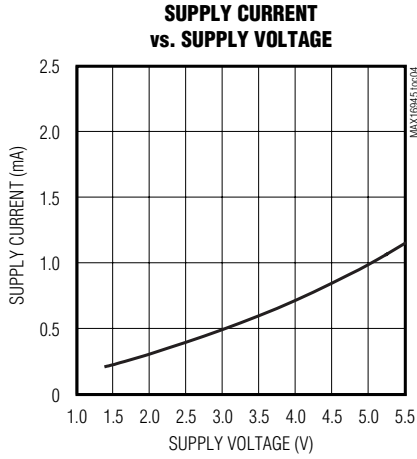

30mA Inverting Charge Pump in SOT23 for EMI-Sensitive Automotive Applications

MAX16945

Typical Operating Characteristics (continued)

(Circuit of Figure 1, $C_1 = C_2 = 2.2\mu\text{F}$, $V_{\text{IN}} = V_{\text{SHDN}} = +5\text{V}$, $V_{\text{GND}} = 0$, $T_A = +25^\circ\text{C}$, unless otherwise noted.)

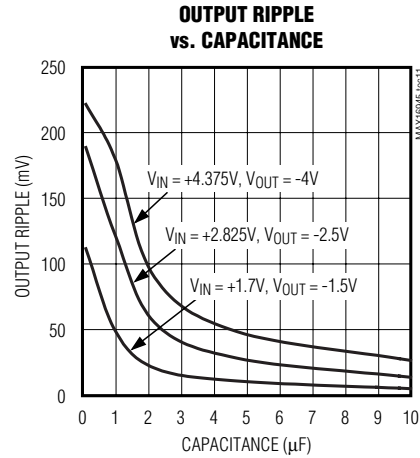
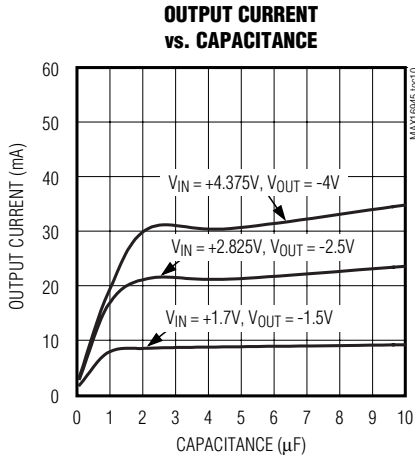

Pin Description

PIN	NAME	FUNCTION
1	OUT	Inverting Charge-Pump Output
2	IN	Power-Supply Voltage Input. Input range is 1.4V to 5.5V.
3	C1-	Negative Terminal of the Flying Capacitor
4	GND	Ground
5	$\overline{\text{SHDN}}$	Shutdown Input. Drive $\overline{\text{SHDN}}$ high for normal operation; drive $\overline{\text{SHDN}}$ low for shutdown mode. OUT is actively pulled to ground during shutdown.
6	C1+	Positive Terminal of the Flying Capacitor

Detailed Description

The MAX16945 capacitive charge pump inverts the voltage applied to its input. For highest performance, use low-ESR capacitors.

During the first half-cycle, switches S2 and S4 open, switches S1 and S3 close, and capacitor C1 charges to the voltage at IN (Figure 2). During the second half-cycle, S1 and S3 open, S2 and S4 close, and C1 is level shifted downward by V_{IN} volts. This connects C1 in parallel with the reservoir capacitor C2. If the voltage across C2 is smaller than the voltage across C1, charge flows from C1 to C2 until the voltage across C2 reaches $-V_{\text{IN}}$. The absolute value of the inverting output

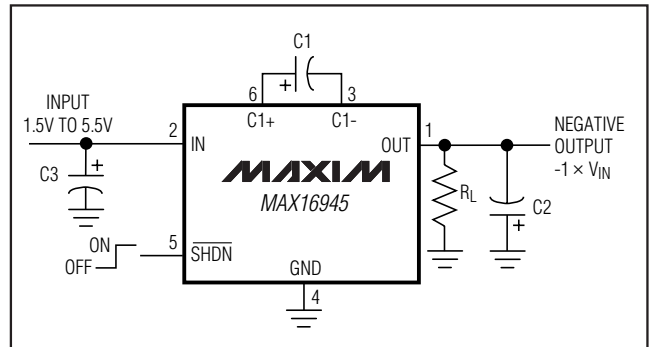

Figure 1. Typical Application Circuit

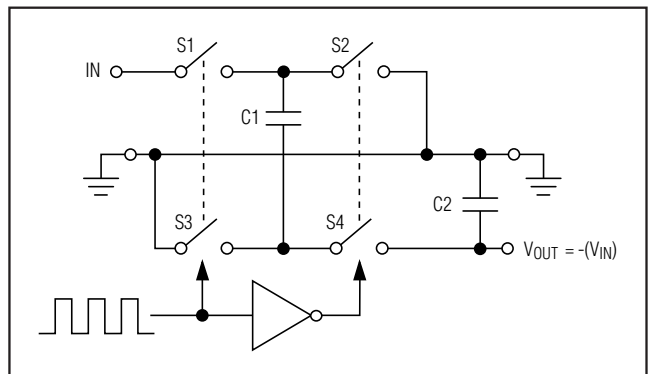

Figure 2. Ideal Voltage Inverter

voltage is always smaller than the value of the input voltage due to the losses of the flying capacitor C1 and the resistance of the switches S1–S4.

30mA Inverting Charge Pump in SOT23 for EMI-Sensitive Automotive Applications

Efficiency Considerations

The efficiency of the MAX16945 is dominated by its quiescent supply current (I_Q) at low output current, and by its output impedance (R_{OUT}) at higher output current. Efficiency is calculated as follows:

$$\eta \cong \frac{I_{OUT}}{I_{OUT} + I_Q} \left(1 - \frac{I_{OUT} \times R_{OUT}}{V_{IN}} \right)$$

where the output impedance is roughly approximated by:

$$R_{OUT} \cong \frac{1}{(f_{OSC}) \times C1} + 2R_{SW} + 4ESR_{C1} + ESR_{C2}$$

The first term is the effective resistance of an ideal switched-capacitor circuit (Figures 3a and 3b), and R_{SW} is the sum of the charge pump's internal switch resistances (typically 4Ω to 5Ω at $V_{IN} = +5V$). The typical output impedance is more accurately determined from the *Typical Operating Characteristics*.

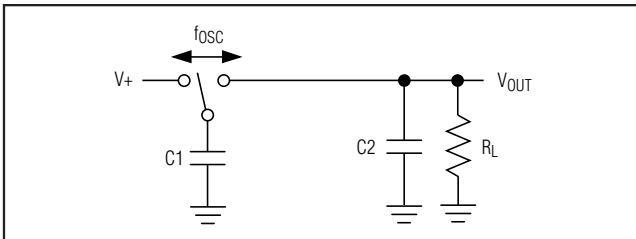

Figure 3a. Switched-Capacitor Model

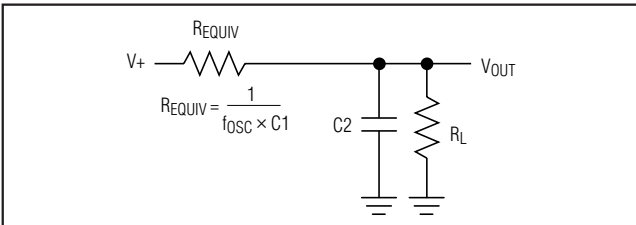

Figure 3b. Equivalent Circuit

Current Limit

The MAX16945 limits its input current upon startup to 170mA (typ). This prevents low-current or higher output impedance input supplies (such as alkaline cells) from being overloaded when power is applied or when the device awakes from shutdown.

Shutdown

The MAX16945 has a logic-controlled shutdown input. Driving \overline{SHDN} low places the device in a low-power shutdown mode. The charge-pump switching halts, supply current is reduced to 2nA, and OUT is actively pulled to ground through a 3Ω resistance.

Driving \overline{SHDN} high will restart the charge pump. The switching frequency and capacitor values determine how soon the device will reach 90% of the input voltage.

Applications Information

Capacitor Selection

The charge-pump output resistance is a function of the ESR of C1 and C2. To maintain the lowest output resistance, use capacitors with low ESR.

Flying Capacitor (C1)

Increasing the flying capacitor's value reduces the output resistance. Above a certain point, increasing C1's capacitance has negligible effect because the output resistance is then dominated by internal switch resistance and capacitor ESR.

Output Capacitor (C2)

Increasing the output capacitor's value reduces the output ripple voltage. Decreasing its ESR reduces both output resistance and ripple. Lower capacitance values can be used with light loads if higher output ripple can be tolerated. Use the following equation to calculate the peak-to-peak ripple:

$$V_{RIPPLE} = \frac{I_{OUT}}{2(f_{OSC})C2} + 2 \times I_{OUT} \times ESR_{C2}$$

Input Bypass Capacitor (C3)

If necessary, bypass the incoming supply to reduce its AC impedance and the impact of the MAX16945's switching noise. An input bypass capacitor (C3) with a value equal to that of C1 is recommended.

Voltage Inverter

The most common application for these devices is a charge-pump voltage inverter (Figure 1). This application requires only two external components, capacitors C1 and C2, plus an input bypass capacitor C3, if necessary. See the *Capacitor Selection* section for suggested capacitor sizes.

30mA Inverting Charge Pump in SOT23 for EMI-Sensitive Automotive Applications

MAX16945

Cascading Devices

Two devices can be cascaded to produce an even larger negative voltage (Figure 4). The unloaded output voltage is normally $-2 \times V_{IN}$, but this is reduced slightly by the output resistance of the first device when multiplied by the quiescent current of the second. When cascading more than two devices, the output resistance rises dramatically. The maximum load current and startup current of the n th cascaded circuit must not exceed the maximum output current capability of the $(n-1)$ th circuit to ensure proper startup.

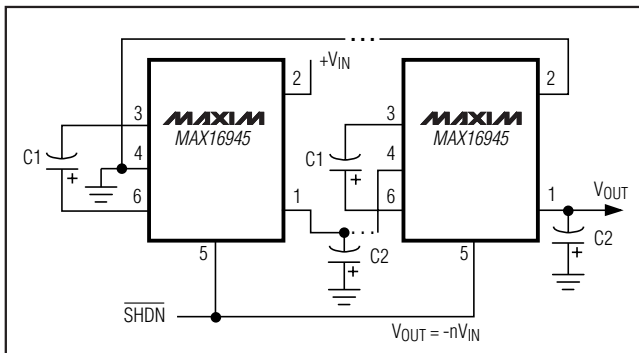

Figure 4. Cascading MAX16945s to Increase Output Voltage

Paralleling Devices

Paralleling multiple MAX16945s reduces the output resistance. Each device requires its own charge-pump capacitor (C1), but the reservoir capacitor (C2) serves all devices (Figure 5). Increase C2's value by a factor of n , where n is the number of parallel devices. Figure 5 shows the equation for calculating output resistance.

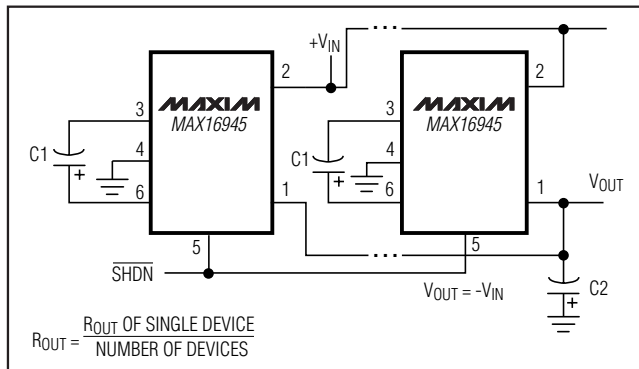

Figure 5. Paralleling MAX16945s to Reduce Output Resistance

Combined Doubler/Inverter

In the circuit of Figure 6, capacitors C1 and C2 form the inverter, while C3 and C4 form the doubler. C1 and C3 are the pump capacitors; C2 and C4 are the reservoir capacitors. Because both the inverter and doubler use part of the charge-pump circuit, loading either output causes both outputs to decline toward GND. Make sure the sum of the currents drawn from the two outputs does not exceed 30mA.

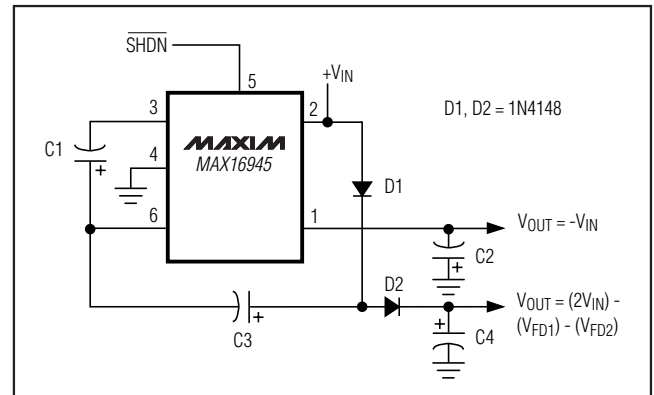

Figure 6. Combined Doubler and Inverter

Heavy Load Connected to a Positive Supply

Under heavy loads, where a higher supply is sourcing current into OUT, the OUT supply must not be pulled above ground. Applications that sink heavy current into OUT require a Schottky diode (1N5817) between GND and OUT, with the anode connected to OUT (Figure 7).

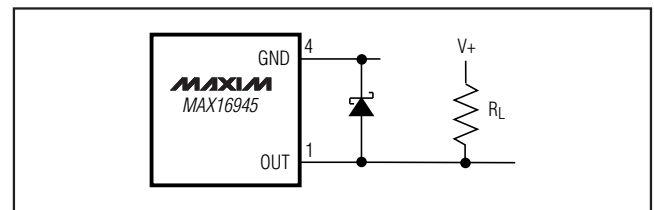

Figure 7. Heavy Load Connected to a Positive Supply

Layout and Grounding

Good layout is important, primarily for good noise performance. To ensure good layout, mount all components as close together as possible, keep traces short to minimize parasitic inductance and capacitance, and use a ground plane.

30mA Inverting Charge Pump in SOT23 for EMI-Sensitive Automotive Applications

Chip Information

Process: BiCMOS

Package Information

For the latest package outline information and land patterns, go to www.maxim-ic.com/packages. Note that a "+", "#", or "-" in the package code indicates RoHS status only. Package drawings may show a different suffix character, but the drawing pertains to the package regardless of RoHS status.

PACKAGE TYPE	PACKAGE CODE	DOCUMENT NO.
6 SOT23	U6F+16	21-0058

30mA Inverting Charge Pump in SOT23 for EMI-Sensitive Automotive Applications

Revision History

REVISION NUMBER	REVISION DATE	DESCRIPTION	PAGES CHANGED
0	8/08	Initial release	—
1	6/09	Updated <i>Ordering Information</i> .	1

MAX16945

Maxim cannot assume responsibility for use of any circuitry other than circuitry entirely embodied in a Maxim product. No circuit patent licenses are implied. Maxim reserves the right to change the circuitry and specifications without notice at any time.

Maxim Integrated Products, 120 San Gabriel Drive, Sunnyvale, CA 94086 408-737-7600 _____ 9