

MAXIM

MAX1676 Evaluation Kit

Evaluates: MAX1676

General Description

The MAX1676 is a high-efficiency, step-up DC-DC converter for portable hand-held devices. It accepts a positive input voltage between 0.7V to 5.5V and converts it to a higher output voltage. The MAX1676 includes a damping circuit (at BATT) that suppresses inductor ringing to reduce electromagnetic interference (EMI).

The MAX1676 evaluation kit (EV kit) is a fully assembled and tested surface-mount printed circuit board. Three jumpers on the EV kit allow for easy access to the output voltage select, current limit, and shutdown features.

The output voltage is both adjustable and pin-selectable. A movable jumper selects either a 3.3V or 5.0V output, or it can be left open and a resistor network can be used to obtain a voltage in the 2V to 5.5V range. The inductor current limit is selectable for either 0.5A or 1.0A. In shutdown mode, the MAX1676 typically draws only 0.1 μ A.

Component List

DESIGNATION	QTY	DESCRIPTION
C1	1	47 μ F, 16V tantalum capacitor AVX TPSC476M016R0350
C2	1	100 μ F, 10V tantalum capacitor AVX TPSD107M010R0100
C3	1	1 μ F, Y5V ceramic capacitor Taiyo Yuden UMK212F105ZG
C4	1	0.1 μ F, X7R ceramic capacitor Taiyo Yuden UMK212BJ104KG or Murata GRM40X7R104K025AL
D1	0	Diode (not included; needed for 1-cell inputs) Motorola MBR0520
JU1, JU2, JU3	3	3-pin jumpers
L1	1	22 μ H power inductor (1.1A) Sumida CD54-220
R1	1	200 Ω , 5% resistor
R2-R6	0	Open
U1	1	MAX1676EUB

Ordering Information

PART	TEMP. RANGE	IC PACKAGE
MAX1676EVKIT	0°C to +70°C	10 μ MAX

Features

- ◆ Synchronous Rectification for Improved Efficiency
- ◆ Operates Down to 0.7V Input Supply Voltage
- ◆ No External Schottky Diode Required (for multicell applications)
- ◆ Selectable Current Limit (0.5A or 1.0A)
- ◆ Damping Circuit Reduces EMI
- ◆ 16 μ A Quiescent Current
- ◆ 0.1 μ A Typical Shutdown Current
- ◆ Low-Battery Detector (LBI/LBO)
- ◆ 10-Pin μ MAX Package
- ◆ Surface-Mount Construction
- ◆ Fully Assembled and Tested

Component Suppliers

SUPPLIER	PHONE	FAX
AVX	803-946-0690	803-626-3123
Motorola	303-675-2140	303-675-2150
Murata	814-237-1431	814-238-0490
Sumida	847-956-0666	847-956-0702
Taiyo Yuden	408-573-4150	408-573-4159

Quick Start

The MAX1676 EV kit is a fully assembled and tested surface-mount board. Follow the steps below to verify board operation. **Do not turn on the power supply until all connections are completed.**

- 1) Connect a 1.1V to 3V supply to the pads marked +VBATT and GND.
- 2) Connect a voltmeter and load (if any) to the VOUT pad.
- 3) Place the shunt on JU3 across pins 1 and 2.
- 4) Place the shunt on JU1 across pins 1 and 2 for a 3.3V output voltage.
- 5) Place the shunt on JU2 across pins 1 and 2 for a 1A current limit.
- 6) Turn on the power and verify that the output voltage is 3.3V.
- 7) Refer to the *Output Voltage Selection* section to modify the board for a different output voltage.



Maxim Integrated Products 1

For free samples & the latest literature: <http://www.maxim-ic.com>, or phone 1-800-998-8800.
For small orders, phone 408-737-7600 ext. 3468.

MAX1676 Evaluation Kit

Detailed Description

Input Source

The input source for the MAX1676 EV kit must be greater than 1.1V for guaranteed start-up (0.7V for operation once started), and less than the output voltage. A typical input voltage range would be the 2.0V to 3.3V range of a 2-cell NiCd battery. An input voltage greater than the selected output voltage (but less than 6V) will not damage the circuit, but under these circumstances, the MAX1676's output will equal the input voltage minus the 0.7V drop of the internal diode (0.3V if D1, the Schottky diode, is in the circuit).

Once started, the MAX1676 operates from the regulated output voltage. This means that the input voltage can fall below the 1.1V minimum guaranteed start-up voltage. Typically, the regulated output will be maintained even if the input voltage drops to 0.7V.

Single-Cell Operation

When using a single-cell battery, diode D1 must be installed to ensure low-voltage start-up. Use a Motorola MBR0520 or equivalent Schottky diode.

Jumper Selection

Three 3-pin jumpers select the output voltage, current limit, and shutdown mode. Table 1 lists the selectable jumper options.

Table 1. Jumper Selection Options

JUMPER	JUMPER POSITION	FUNCTION
JU1	1-2	3.3V fixed output
	2-3	5V fixed output
	Open	Adjustable output using resistor-divider R1 and R2.
JU2	1-2	Inductor peak current limited to 1.0A.
	2-3	Inductor peak current limited to 0.5A.
JU3	1-2	$\overline{\text{SHDN}}$ = High. MAX1676 enabled.
	2-3	$\overline{\text{SHDN}}$ = Low. MAX1676 disabled.
	Open	Drive pad $\overline{\text{SHDN}}$ with an external signal.

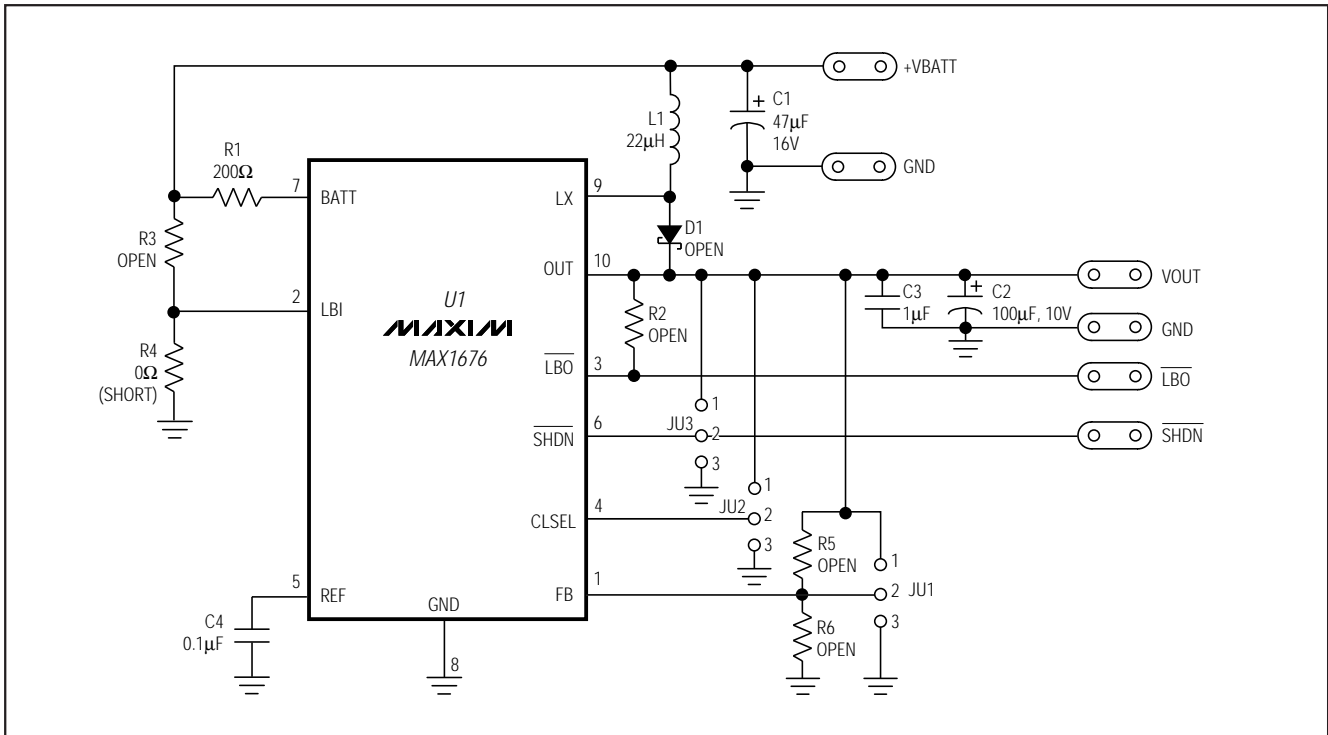

Figure 1. MAX1676 EV Kit Schematic

MAX1676 Evaluation Kit

Evaluates: MAX1676

Using the Low-Battery Detector

The MAX1676 has an additional comparator useful for monitoring the input source's voltage level. Resistors R3 and R4 are connected as a voltage-divider between the +VBATT pad and the MAX1676 LBI pin. Note that a printed circuit trace across R4 shorts the LBI pin to ground when this function is not used. Cut the trace before installing R4.

Another location on the board facilitates the addition of a pull-up resistor on the LBO output. The LBO output is an open-drain output that can sink 1mA. Install resistor R2 if an external circuit is to be driven from LBO.

Refer to the *Low-Battery Detection* section of the MAX1674/MAX1675/MAX1676 data sheet for instructions on selecting values for resistors R2, R3, and R4.

Output Voltage Selection

The MAX1676 is initially set to output either 3.3V or 5V, depending on the position of JU1. However, by adding external resistors, the output can be adjusted from 2.0V to 5.5V. Remove the shunt on JU1 and add the output voltage-divider resistors R5 and R6. The *Selecting the Output Voltage* section of the MAX1674/MAX1675/MAX1676 data sheet gives instructions for calculating R5 and R6 values.

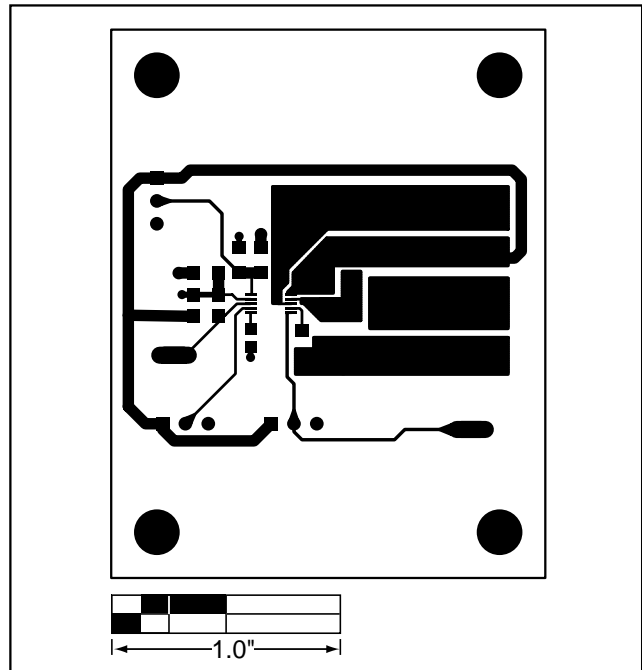

Figure 3. MAX1676 EV Kit PC Board Layout—Component Side

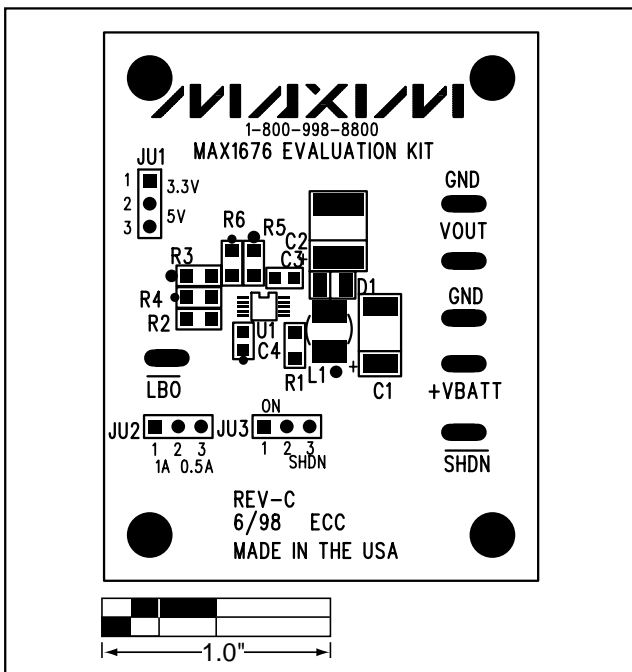

Figure 2. MAX1676 EV Kit Component Placement Guide—Component Side

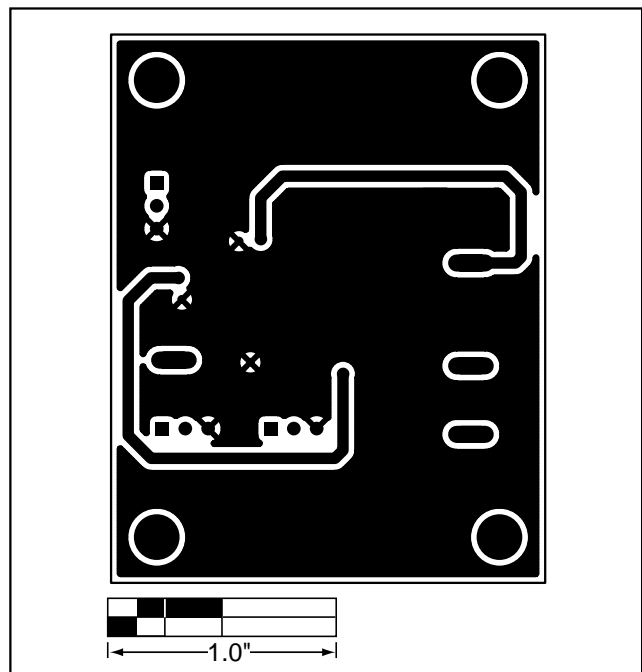

Figure 4. MAX1676 EV Kit PC Board Layout—Solder Side

MAX1676 Evaluation Kit

Evaluates: MAX1676

NOTES

Maxim cannot assume responsibility for use of any circuitry other than circuitry entirely embodied in a Maxim product. No circuit patent licenses are implied. Maxim reserves the right to change the circuitry and specifications without notice at any time.

4 _____ Maxim Integrated Products, 120 San Gabriel Drive, Sunnyvale, CA 94086 408-737-7600

© 1998 Maxim Integrated Products

Printed USA

MAXIM is a registered trademark of Maxim Integrated Products.