

MAXIM

MAX1672 Evaluation Kit

Evaluates: MAX1672

General Description

The MAX1672 evaluation kit (EV kit) integrates a step-up switching converter with a linear-regulator output to provide step-up/down voltage conversion. It accepts a 1.8V to 11V input and converts it to a 3.3V or 5V output for currents up to 300mA. The EV kit is optimized for battery applications where the input varies above and below the regulated output voltage. It provides ultra-low quiescent current and high efficiency for maximum battery life. Another benefit of the low-dropout linear post-regulator is that it reduces high-frequency ripple.

The MAX1672 EV kit is a fully assembled and tested surface-mount circuit board. With minimal modification, it can also be used to evaluate other output voltages. Additional pads on the board accommodate external feedback resistors for setting different output voltages.

Features

- ◆ Step-Up/Down Voltage Conversion
- ◆ 1.8V to 11V Input Range
- ◆ 3.3V or 5V Selectable Output Voltage
- ◆ Adjustable Output Voltage (1.25V to 5.5V)
- ◆ Load Disconnects from Input in Shutdown
- ◆ Up to 300mA Output Current
- ◆ No External FETs Required
- ◆ 0.1µA Typical IC Shutdown Current
- ◆ Low-Battery Comparator
- ◆ 16-Pin QSOP Package (same footprint as 8-pin SO)
- ◆ Surface-Mount Components
- ◆ Fully Assembled and Tested

Component List

DESIGNATION	QTY	DESCRIPTION
C1, C2	2	100µF, 16V, low-ESR tantalum capacitors AVX TPSE107M016R0100 or Sprague 593D107X0016E2W
C3, C5, C6, C7	4	0.1µF ceramic capacitors
C4	1	10µF, 10V tantalum capacitor Sprague 595D106X0010A2T
D1	1	1A, 30V Schottky diode Motorola MBRS130LT3 or International Rectifier 10BQ40
L1	1	10µH inductor Sumida CD54-100
R1-R4	0	Not installed
R5	1	1MΩ, 5% resistor
U1	1	MAX1672EEE (QSOP-16)
JU1-JU4	4	3-pin headers
None	4	Shunts
None	1	MAX1672 PC board
None	1	MAX1672 data sheet

Ordering Information

PART	TEMP. RANGE	BOARD TYPE
MAX1672EVKIT	0°C to +70°C	Surface Mount

Component Suppliers

SUPPLIER	PHONE	FAX
AVX	(803) 946-0690	(803) 626-3123
Coilcraft	(708) 639-6400	(708) 639-1469
Coiltronics	(561) 241-7876	(561) 241-9339
Dale-Vishay	(402) 564-3131	(402) 563-6418
International Rectifier	(310) 322-3331	(310) 322-3332
Motorola	(602) 303-5454	(602) 994-6430
Sprague	(603) 224-1961	(603) 224-1430
Sumida	(708) 956-0666	(708) 956-0702
Vishay/Vitramon	(203) 268-6261	(203) 452-5670

Note: Please indicate that you are using the MAX1672 when contacting these component suppliers.



Maxim Integrated Products 1

For free samples & the latest literature: <http://www.maxim-ic.com>, or phone 1-800-998-8800.
For small orders, phone 408-737-7600 ext. 3468.

MAX1672 Evaluation Kit

Quick Start

The MAX1672 EV kit is fully assembled and tested. Follow these steps to verify board operation. **Do not turn on the power supply until all connections are completed.**

- 1) Connect a +1.8V to +11V supply voltage to the VIN pad. Connect ground to the GND pad.
- 2) Connect a voltmeter to the VOUT pad.
- 3) Verify that all other shunts are across pins 1 and 2 of jumpers JU1–JU4.
- 4) Turn on the power supply and verify that the output voltage is 3.3V. For a 5V output, remove the shunt from JU1 pins 1 and 2, and place it across pins 2 and 3.

Detailed Description

The MAX1672 EV kit integrates a step-up switching converter with a linear-regulator output to provide step-up/down voltage conversion. It accepts a 1.8V to 11V input and converts it to a 3.3V or 5V output for currents up to 300mA. The MAX1672 combines a linear regulator, boost switching regulator, N-channel power MOSFET, P-channel pass element, reference, and low-battery comparator in a single, space-saving, 16-pin QSOP package. The EV kit is shipped configured for a 3.3V output.

Jumper Selection

The 3-pin header JU1 selects the output voltage. Table 1 lists the selectable jumper options. The 3-pin header JU2 selects the current limit. Table 2 lists the selectable jumper options. The EV kit is shipped configured for $I_{LIM} = 0.8A$.

Table 1. Jumper JU1 Functions

SHUNT LOCATION	3/5 PIN	MAX1672 OUTPUT
1 & 2	Connected to V+	$V_{OUT} = 3.3V$
2 & 3	Connected to GND	$V_{OUT} = 5V$

Table 2. Jumper JU2 Functions

SHUNT LOCATION	ILIM PIN	CURRENT LIMIT
1 & 2	Connected to V+	$I_{LIM} = 0.8A$
2 & 3	Connected to GND	$I_{LIM} = 0.5A$

Shutdown Mode

The MAX1672 EV kit features a shutdown mode that preserves battery life by reducing quiescent current to less than 1 μ A max. During shutdown, the reference, low-battery comparator, and all feedback and control circuitry are turned off. In shutdown, the output of the boost converter drops to within a Schottky diode drop below the input, and the linear-regulator output is turned off and pulled to 0V.

The 3-pin headers JU3 and JU4 select the shutdown mode. When $ON_A = 1$ or $\overline{ON_B} = 0$, the MAX1672 is on. When $ON_A = 0$ and $\overline{ON_B} = 1$, the MAX1672 shuts down. For normal operation, connect ON_A to V+ and $\overline{ON_B}$ to GND. Table 3 lists the selectable jumper options.

Table 3. Jumpers JU3 and JU4 Functions

ON_A PIN	$\overline{ON_B}$ PIN	MAX1672 OUTPUT
Connected to GND, JU4 = 2 and 3	Connected to GND, JU3 = 2 and 3	MAX1672 enabled, $V_{OUT} = 3.3V$ or 5V
Connected to GND, JU4 = 2 and 3	Connected to V+, JU3 = 1 and 2	Shutdown mode, $V_{OUT} = 0V$
Connected to V+, JU4 = 1 and 2	Connected to GND, JU3 = 2 and 3	MAX1672 enabled, $V_{OUT} = 3.3V$ or 5V
Connected to V+, JU4 = 1 and 2	Connected to V+, JU3 = 1 and 2	MAX1672 enabled, $V_{OUT} = 3.3V$ or 5V

Power-Good Output

The MAX1672 has an on-chip comparator for low-battery detection. If the voltage at the PGI input falls below 1.25V (REF), the open-drain comparator output PGO goes high. The PGI input is connected to an external resistor-divider, R3 and R4, which sets the low-battery detector threshold.

Refer to the *Low-Battery Detection* section of the MAX1672 data sheet for instructions on selecting resistors R3 and R4.

Other Output Voltages

The MAX1672 EV kit can also be used to evaluate other output voltages in the 1.25V to 5.5V range. Simply cut the PC trace shorting resistor R2 and refer to the *Output Voltage Selection* section in the MAX1672 data sheet for instructions on selecting feedback resistors R1 and R2. Place the shunt across pins 2 and 3 of JU1.

MAX1672 Evaluation Kit

Evaluates: MAX1672

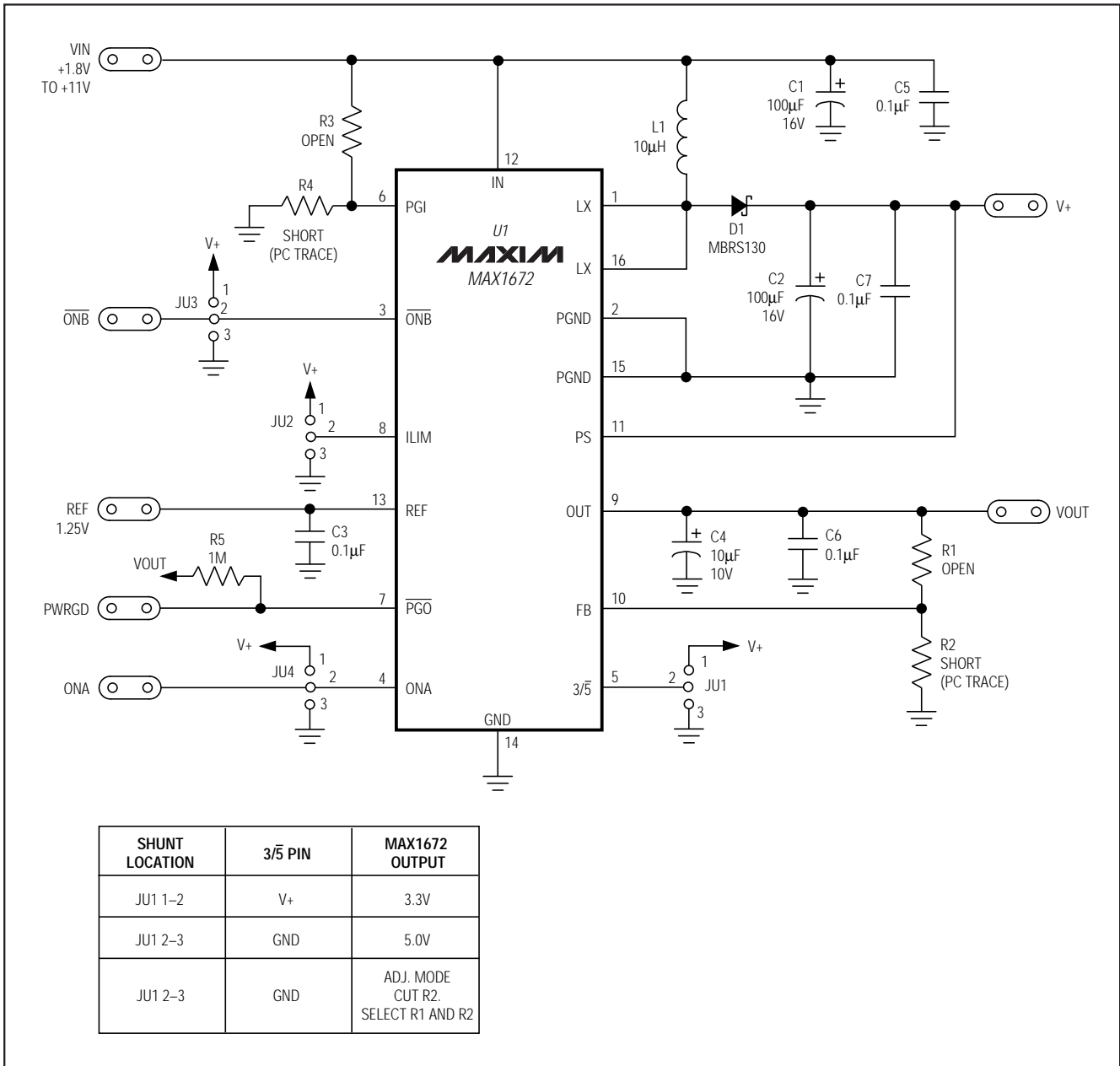

Figure 1. MAX1672 EV Kit Schematic

MAX1672 Evaluation Kit

Evaluates: MAX1672

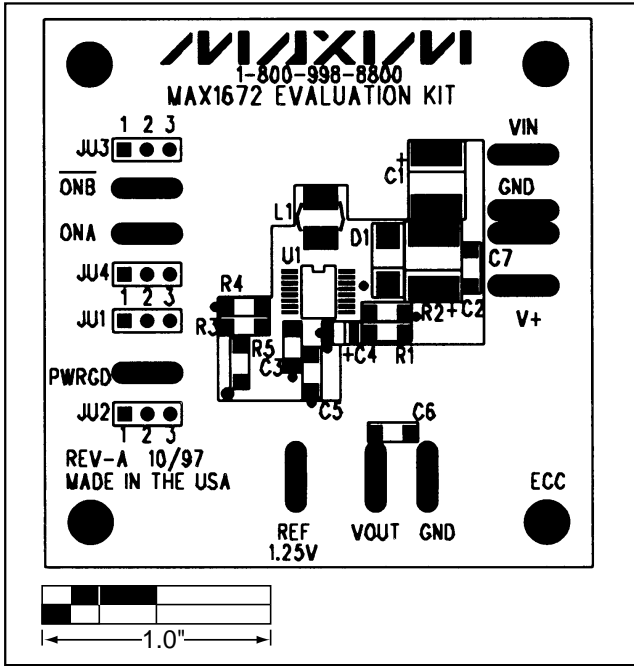

Figure 2. MAX1672 EV Kit Component Placement Guide—Component Side

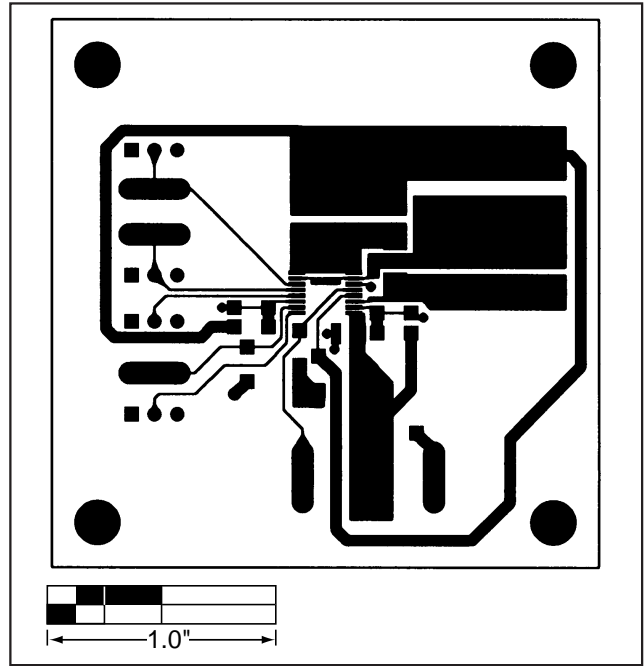

Figure 3. MAX1672 EV Kit PC Board Layout—Component Side

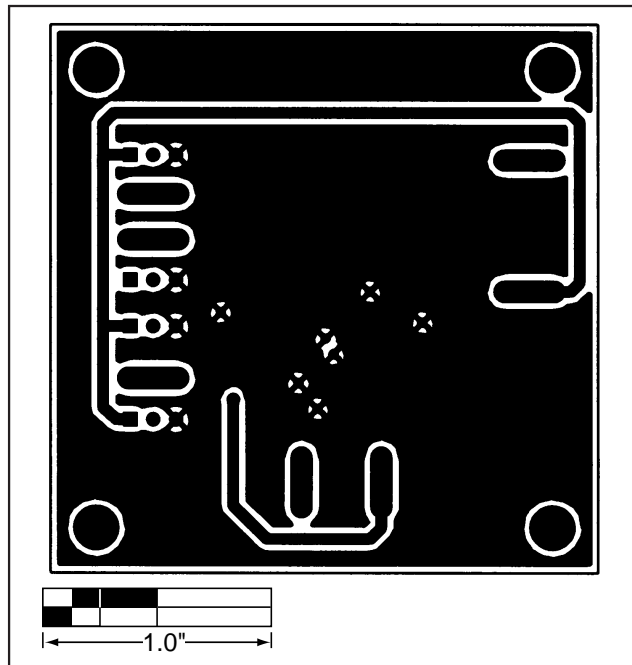

Figure 4. MAX1672 EV Kit PC Board Layout—Solder Side

Maxim cannot assume responsibility for use of any circuitry other than circuitry entirely embodied in a Maxim product. No circuit patent licenses are implied. Maxim reserves the right to change the circuitry and specifications without notice at any time.

4 _____ Maxim Integrated Products, 120 San Gabriel Drive, Sunnyvale, CA 94086 408-737-7600