



MAX1662 Evaluation Kit/Evaluation System

General Description

The MAX1662 evaluation system (EV system) consists of a MAX1662 evaluation kit (EV kit) and a companion Maxim SMBus™ Interface Board. The MAX1662 EV kit is an assembled and tested PC board that demonstrates the MAX1662 load-switch controller.

In addition to controlling power-plane load switches, the MAX1662 is useful for many different SMBus I/O expansion tasks, such as controlling voltage regulators or detecting the state of mechanical switches.

The Maxim SMBus interface board (MAXSMBUS) allows an IBM-compatible personal computer to use its parallel port to emulate an Intel System Management Bus (SMBus)™ two-wire interface. Windows 3.1/Windows 95™ software provide a user-friendly interface to exercise the MAX1662's features. The program is menu-driven and offers a graphics interface with control buttons and status display.

The MAX1662 EV system can also be used to evaluate the MAX1661 or MAX1663. Contact the factory to order a free MAX1661EUB or MAX1663EUB sample.

Order the MAX1662EVSYS for complete IBM PC-based evaluation of the MAX1662.

Order the MAX1662EVKIT if you already have an SMBus interface.

MAX1662EVKIT Component List

DESIGNATION	QTY	DESCRIPTION
C1, C2, C3	0	Not installed
C4	1	0.1µF ceramic capacitor
J1	1	2 x 10 right-angle female receptacle
JU1	1	3-pin jumper
LED1, LED2, LED3	3	Red light-emitting diodes
R1, R4, R7	3	10kΩ, 5% resistors
R2, R5, R8	3	200kΩ, 5% resistors
R10	1	100Ω, 5% resistor
R3, R6, R9	3	1kΩ, 5% resistors
P1, P2, P3	3	Logic-level, P-channel MOSFETs International Rectifier IRF7406
SW1	1	Slide switch
U1	1	Maxim MAX1662EUB
None	1	3 1/2" software disk "MAX1662 Evaluation Kit"

SMBus is a trademark of Intel Corp. Windows is a trademark of Microsoft Corp.



Maxim Integrated Products 1

For free samples & the latest literature: <http://www.maxim-ic.com>, or phone 1-800-998-8800. For small orders, phone 408-737-7600 ext. 3468.

Features

- ◆ Controls up to Three Load Switches Independently
- ◆ Configurable for Three General-Purpose Input/Outputs (GPIO)
- ◆ Includes Three 30V, 4A P-Channel MOSFET Switches
- ◆ SMBus Compatible
- ◆ Easy-to-Use Menu Driven Software
- ◆ Assembled and Tested Surface-Mount Board

Ordering Information

PART	INTERFACE TYPE	IC PACKAGE
MAX1662EVKIT	User-Supplied	10 µMAX
MAX1662EVSYS	Windows Software	10 µMAX

Note: The MAX1662 software can be used only with the complete evaluation system MAX1662EVSYS, which includes the MAXSMBUS interface board and the MAX1662EVKIT.

MAX1662EVSYS Component List

DESIGNATION	QTY	DESCRIPTION
None	1	MAX1662EVKIT
None	1	MAXSMBUS

Component Suppliers

SUPPLIER*	PHONE	FAX
International Rectifier	(310) 322-3331	(310) 322-3332

*Please indicate that you are using the MAX1662 when contacting International Rectifier.

Evaluates: MAX1661/MAX1662/MAX1663

MAX1662 Evaluation Kit/Evaluation System

Quick Start

Required Equipment

Before you begin, you will need the following equipment:

- An IBM PC-compatible computer capable of running Windows 3.1 or Windows 95
- A spare parallel printer port (this is a 25-pin socket on the back of the computer)
- A standard 25-pin, straight-through, male-to-female cable to connect the computer's parallel port to the Maxim SMBus interface board
- A small DC power supply capable of supplying 7V to 20V at 100mA

Procedure

- 1) Carefully connect the boards by aligning the 20-pin connector of the MAX1662 EV kit with the 20-pin header of the MAXSMBUS interface board. Gently press them together. The two boards should be flush against each other.
- 2) Make sure switch SW1 on the MAX1662 EV kit is in the "off" position.
- 3) Connect a +7V to +20V DC power supply to the pads labeled POS9 and GND1 of the SMBus interface board.
- 4) Make sure JU1 is set to the 1-2 position.
- 5) Connect a cable from the computer's parallel port to the SMBus interface board. Use a straight-through 25-pin female-to-male cable. To avoid damaging the EV kit or your computer, do not use a 25-pin SCSI port or any other connector that is physically similar to the 25-pin parallel printer port.
- 6) Run the MAX1662.EXE software program from either the floppy drive or the hard drive. Simply use the Windows Program Manager to run the program. If desired, you may use the INSTALL.EXE program to copy the files and create icons for them in the Windows 3.1 Program Manager (or the Windows 95 Start Menu). An uninstall program is included with the software. Simply click on the UNINSTALL icon to remove the MAX1662 EV kit software from the hard drive.
- 7) Turn the EV kit on by moving SW1 to the "on" position.
- 8) Start the MAX1662 program by opening its icon in the Program Manager (or Start Menu).
- 9) When the program prompts you to do so, select the correct parallel port. An auto-detect routine identi-

fies the port to which the EV kit is connected, and selects it as the default choice by highlighting it. Verify that the correct port is highlighted; then select "OK".

- 10) Observe as the program automatically detects the address of the MAX1662 and starts the main program.

Detailed Description of Software

The software allows you to select between the IC's normal and suspend-mode registers. Configuration boxes allow for all interrupts (except Thermal Shutdown) to be individually masked or unmasked and the three MOSFET switches to be independently switched on or off. A status box indicates the states of the I/O pins and is automatically updated several times a second. The automatic update feature can be turned off and the status updated manually.

Note: In the following sections, words in bold face are user-selectable features in the software.

Main Display

The Normal Configuration and Suspend Configuration boxes allow the user to configure the desired IC register settings.

The **Normal Register** is selected at program start-up. To make changes to the suspend-mode register, click on **Suspend Register** with the mouse or use the TAB and arrow keys to navigate until the selection is highlighted.

Inside the configuration boxes are check-boxes that allow the interrupts to be masked or unmasked and the loads to be toggled on or off.

Changes to the configurations can be made only to the register that is currently highlighted. The changes are sent to the IC only after the **Write Config** button is selected. Switching to the other register before selecting **Write Config** results in the reset of any changes to the previous condition.

The Status Box shows the state of the I/O pins and indicates a thermal shutdown. At program start-up the status box is automatically updated. This feature can be turned on or off with the **Automatically Update Status** check-box.

The Alert Box indicates if an interrupt occurred. When an interrupt condition is generated, a message appears in the alert box: "ALERT! INT = LOW". The alert condition will last until **Read Alert** is selected. This action reads the alert response address, returns the value of the MAX1662 address, and clears the interrupt.

MAX1662 Evaluation Kit/Evaluation System

Note: The seven most significant bits of the alert box are the address bits. The least significant bit is the read/write status bit.

The **Reset** button will set the MAX1662 and the software to a power-on reset state. If the address is changed on the MAX1662, selecting **Reset** will also find the new address. If in doubt, select the reset button.

SMBus Menu

The **SMBus** menu allows individual SMBus operations such as Read Byte and Write Byte to be performed. When using SMBus menu operations, turn off **Automatically Update Status** to prevent errors.

The SMBus dialog boxes accept numeric data in binary, decimal, or hexadecimal. Hexadecimal numbers must be prefixed by \$ or 0x. Binary numbers must be exactly eight digits.

Detailed Description of Hardware

The MAX1662 EV kit provides a proven PC board layout to facilitate evaluation of the MAX1662. It requires a power supply and appropriate timing signals to operate.

The Maxim SMBus interface board converts signals from the parallel port of a computer to open-drain SMBus clock and data. It also interfaces the alert (ALERT) and suspend (SMBSUS) pins to the computer and supplies power to the MAX1662 EV kit.

The MAX1662 EV kit is configured with three P-channel logic-level MOSFET switches. MOSFET P1 is controlled by I/O1 of the MAX1662, P2 by I/O2, and P3 by I/O3. For evaluation purposes each MOSFET drives an LED; however, an external load can be used in place of the LEDs. See the section *Driving an External Load*.

The MAX1662 EV kit is initially set up to switch 5V at 20mA to power three LEDs. Each MOSFET can be reconfigured. For example, disconnecting the MOSFETs from the +5V supply isolates them from each other, making it possible to switch a different voltage with each one. For switching up to 15V, follow the directions under *Switching Voltages Higher than 5V*. To switch up to 28V, refer to the section *Switching 28V*.

Jumper Settings

The 3-pin header JU1 controls the address (pin 6) on the IC (Table 1).

Table 1. JU1 Shunt Settings for SMBus Address

JUMPER	STATE	ADDRESS		
		MAX1661	MAX1662	MAX1663
JU1	GND	0100000	0100001	0100010
	Open	0111100	0111101	0111110
	VCC	1001000	1001001	1001010

Note: When changing JU1's setting, move switch SW1 off, then on. Also note that the MAX1662 reads the address select pin at device power-up only.

Table 2. External Load Configuration

I/O	MOSFET	CONNECT LOAD TO PADS	CUT TRACE
I/O1	P1	D1-GND	JU4
I/O2	P2	D2-GND	JU7
I/O3	P3	D3-GND	JU10

Table 3. External Power Supply Configuration

I/O	MOSFET	APPLY VOLTAGE TO PADS	CUT TRACE
I/O1	P1	S1-GND	JU3
I/O2	P2	S2-GND	JU6
I/O3	P3	S3-GND	JU9

Driving an External Load

To configure an output to drive an external load, remove the LED from the circuit (Table 2).

Note: The 5V supplied by the Maxim SMBus interface board is limited to approximately 20mA. If more current is needed, follow the directions listed in *Switching Voltages Higher than 5V*, and use an external power supply.

Switching Voltages Higher than 5V

To configure an output to switch 15V across the loads, isolate the MOSFETs from the +5V supply and apply an external voltage from MOSFET source to GND (Table 3).

Note: The IRF7406 MOSFET has a 20V gate-to-source voltage limit.

Evaluates: MAX1661/MAX1662/MAX1663

MAX1662 Evaluation Kit/Evaluation System

Switching Voltages Lower than 5V

To switch lower voltages, such as 3.3V supply, replace the IRF7406 MOSFETs with devices having lower threshold voltages (such as the IRF7404). In addition, isolate the MOSFET source connections from the +5V supply (Table 3).

Switching 28V

The MAX1662 EV kit can switch 28V if a voltage divider is used to prevent the gate-to-source voltage from exceeding the MOSFET's rating. Follow the procedure in *Switching Voltages Higher than 5V* to isolate the

MOSFETs from the +5V supply. To use I/O1, cut the trace across JU2 and solder an 8.2k Ω resistor in its place. For I/O2 or I/O3, cut the trace across JU5 or JU8, respectively, and solder in a 8.2k Ω resistor.

Note: The MAX1662 has an absolute maximum rating of 30V between I/O and GND.

Configuring the Board for GPIO

To configure the board for general-purpose I/O (GPIO), isolate the MAX1662's I/O pins by cutting PC board traces JU2, JU5, and JU8 and by using the pads labeled I/O1, I/O2, or I/O3.

Table 4. Jumper Function Table

JUMPER	STATE	FUNCTION
JU1	1-2*	Address pin connected to V _{CC} .
	2-3	Address pin connected to GND.
	Open	Address pin floating.
JU2	Open	Configure for GPIO.
	Closed (Default Trace)*	Use supplied MOSFET.
JU3	Open	Use a higher voltage on the MOSFET.
	Closed (Default Trace)*	Drive MOSFET with the boards 5V.
JU4	Open	Drive an external load.
	Closed (Default Trace)*	Use LED1.
JU5	Open	Configure for GPIO.
	Closed (Default Trace)*	Use supplied MOSFET.
JU6	Open	Use a higher voltage on the MOSFET.
	Closed (Default Trace)*	Drive MOSFET with the boards 5V.
JU7	Open	Drive an external load.
	Closed (Default Trace)*	Use LED2.
JU8	Open	Configure for GPIO.
	Closed (Default Trace)*	Use supplied MOSFET.
JU9	Open	Use a higher voltage on the MOSFET.
	Closed (Default Trace)*	Drive MOSFET with the boards 5V.
JU10	Open	Drive an external load.
	Closed (Default Trace)*	Use LED3.

*Indicates default jumper state.

MAX1662 Evaluation Kit/Evaluation System

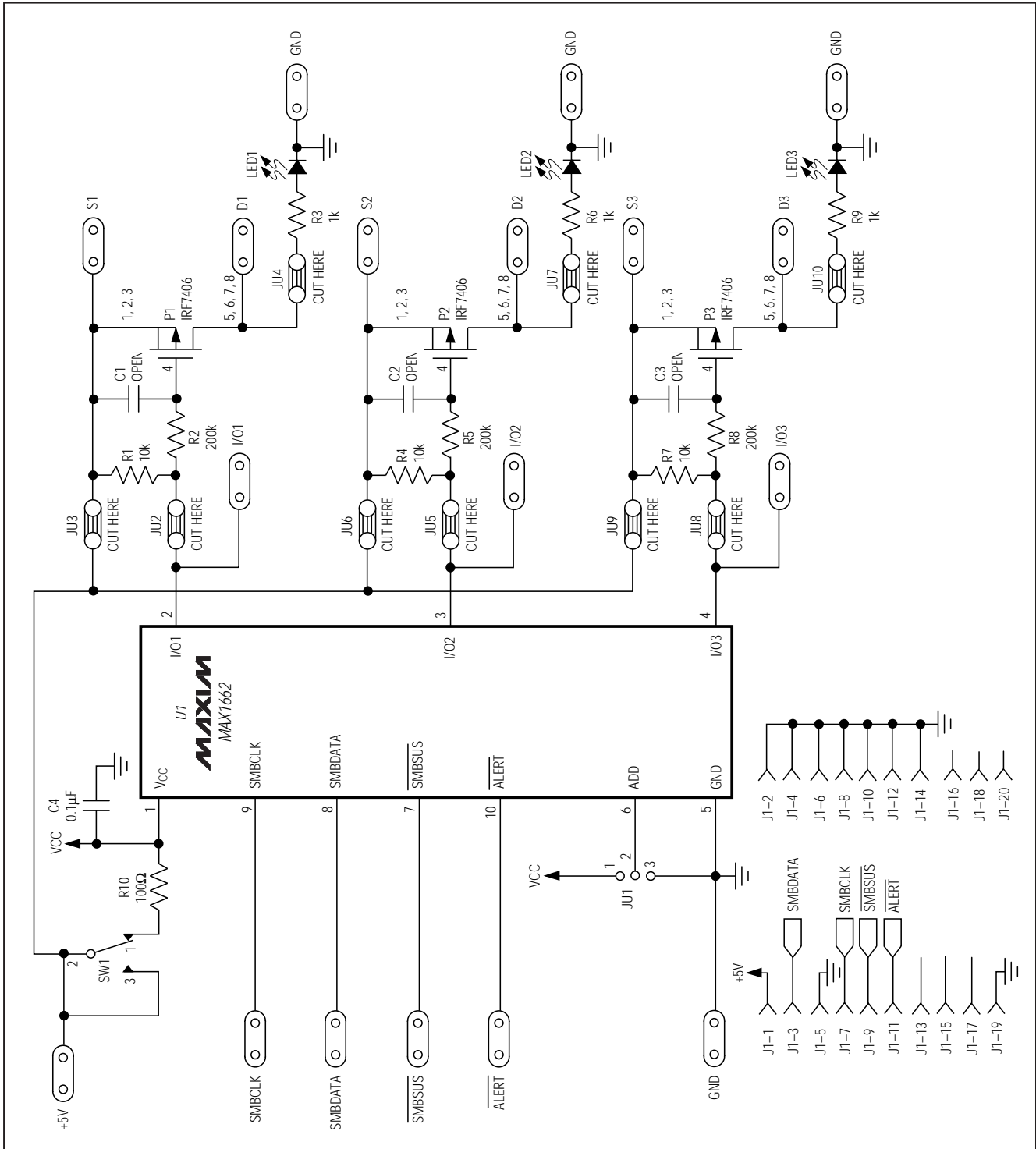

Figure 1. MAX1662 EV Kit Schematic

MAX1662 Evaluation Kit/Evaluation System

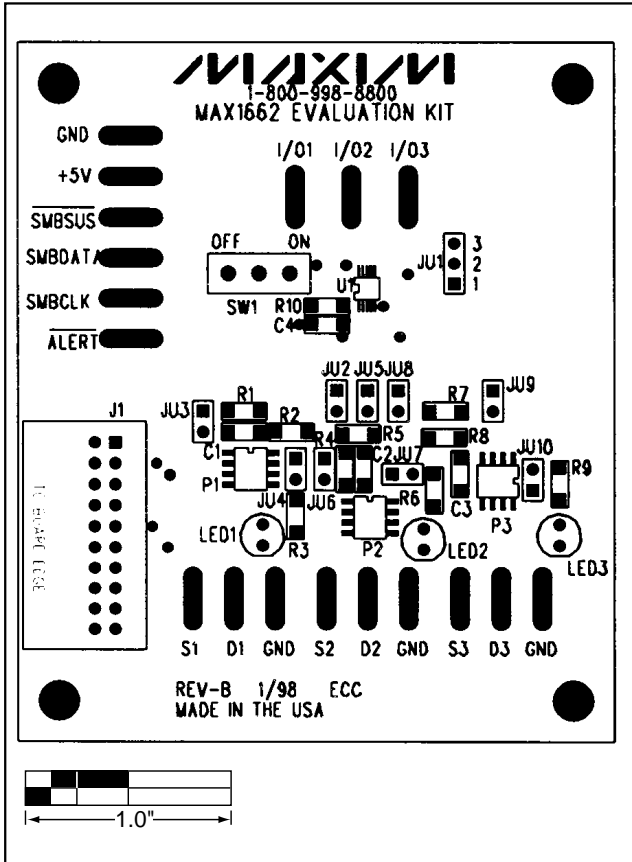

Figure 2. MAX1662 EV Kit Component Placement Guide

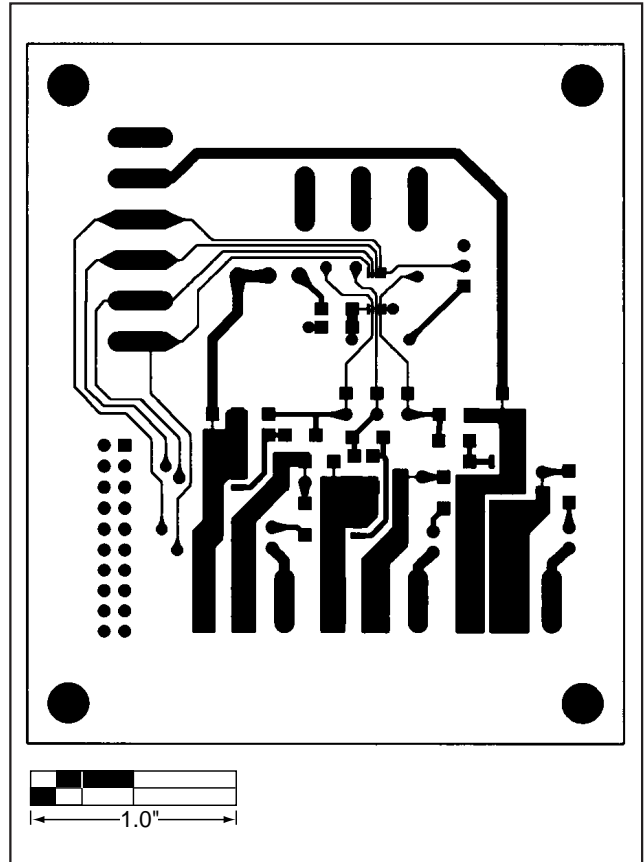

Figure 3. MAX1662 EV Kit PC Board Layout—Component Side

MAX1662 Evaluation Kit/Evaluation System

Evaluates: MAX1661/MAX1662/MAX1663

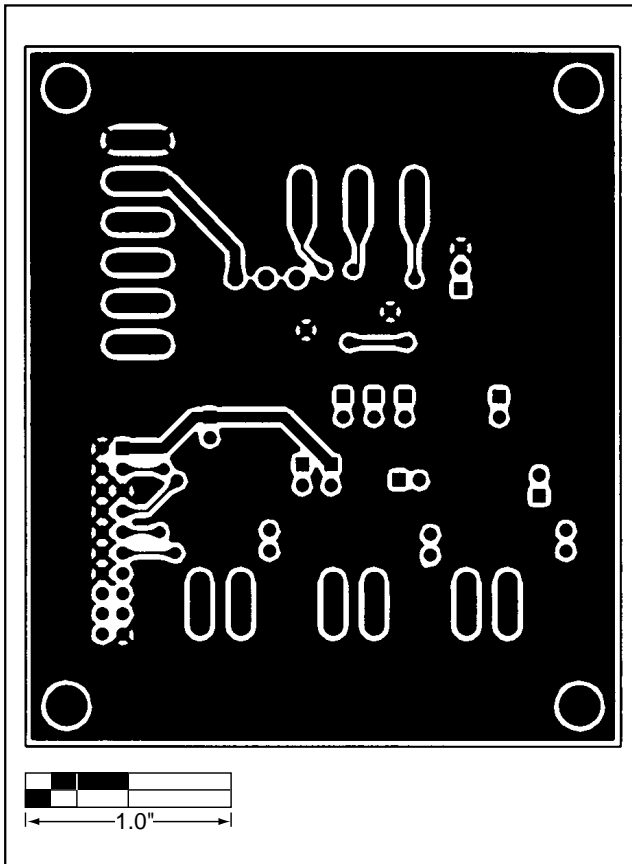

Figure 4. MAX1662 EV Kit PC Board Layout—Solder Side

MAX1662 Evaluation Kit/Evaluation System

NOTES

Evaluates: MAX1661/MAX1662/MAX1663

Maxim cannot assume responsibility for use of any circuitry other than circuitry entirely embodied in a Maxim product. No circuit patent licenses are implied. Maxim reserves the right to change the circuitry and specifications without notice at any time.

8 _____ Maxim Integrated Products, 120 San Gabriel Drive, Sunnyvale, CA 94086 408-737-7600

© 1998 Maxim Integrated Products

Printed USA

MAXIM is a registered trademark of Maxim Integrated Products.



Two-Wire Interface Board

General Description

MAXSMBus is an interface between an IBM-compatible PC and System Management Bus (SMBus)[™]-compatible serial-interface devices such as temperature monitors, voltage regulators, or A/D converters (ADCs). The MAXSMBus interface board is connected between the PC parallel port and the device under test, converting parallel data into two-wire, open-drain serial data. The board is provided for use with selected Maxim products and is not intended to replace commercially available SMBus hardware. MAXSMBus is shipped with a companion EV kit board, including all relevant software.

Maxim SMBus Interface Board Component List

DESIGNATION	QTY	DESCRIPTION
C1, C2, C3	3	0.1 μ F ceramic capacitors
C4-C9	6	3.3 μ F, 25V tantalum capacitors
D1	1	1N5235B zener diode, 6.8V
D2	1	1N5229B zener diode, 4.3V
D3	1	1N4148 small signal diode
J1	1	DB25 right angle plug
J2	1	Not installed
P1	1	2 x 10 right angle male header
R1, R2, R3, R10, R11	5	47k Ω , 5% resistors
R4-R7	4	4.7k Ω , 5% resistors
R8, R9	2	1k Ω , 5% resistors
U1	1	74HC05 hex open-collector inverter
U2	1	74HC04 hex inverter
U3	1	74HC08 quad AND gate
U4	1	74HC74 dual D flip-flop
U5	1	+5V, 100mA regulator, LM78L05ACM
U6	1	MAX865EUA (8 μ MAX)
U7	1	MAX367CWN (18 SO)
NONE	1	PC board

SMBus is a trademark of Intel Corp.



Maxim Integrated Products 1

For free samples & the latest literature: <http://www.maxim-ic.com>, or phone 1-800-998-8800.
For small orders, phone 408-737-7600 ext. 3468.

Features

- ◆ SMBus-Compatible Two-Wire Interface
- ◆ SMBus Suspend Output
- ◆ Two SMBus Alert Inputs
- ◆ Overvoltage Fault Protection
- ◆ PC Parallel Port Interface

Ordering Information

PART	BOARD TYPE
MAXSMBus	Companion Board for SMBus EV Kits

MAXSMBus Functionality Check

Follow these steps to verify that the MAXSMBus interface board is functioning properly. All necessary software is supplied on a disk with the companion EV kit. Instructions for operating the software are included in the EV kit manual.

- 1) Connect a +9V DC supply (+7V minimum, +20V maximum) to the MAXSMBus interface board at the terminals labeled "POS9" and "GND" in the lower left corner of the board.
- 2) Use a digital voltmeter to verify that the oval pad labeled "POS5" is +5V (+4.75V minimum, +5.25V maximum). Also verify that the pads labeled "SBDAT1," "SBCLK1," "SBSUS1," "ALERT1," and "ALERT2" are above +4V.
- 3) If these DC voltages are correct, MAXSMBus passes the functionality test.

Detailed Description

The MAXSMBus interface board provides all of the interface signals necessary to interface an IBM PC-compatible computer with an SMBus-compliant device. A DB25 right-angle plug connects to the computer (Table 1). The companion board plugs into a 20-pin dual-row right-angle header at the edge of the board (Table 2). Alternatively, connection can be made by soldering wires to the oval pads as appropriate. This allows the companion board to be placed in an environmental chamber for evaluation over temperature.

Refer to the documentation of the companion Maxim EV kit for quick start and operating instructions.

Two-Wire Interface Board

Power Supply

The interface board is powered by a 78L05 linear regulator. The companion board can draw about 20mA of +5V power through the circuit protector. Companion boards that require more power must provide their own regulator. The unregulated input to the 78L05 is available on the right-angle header.

Fault Protection Circuitry

Overvoltage fault protection is provided by a MAX367 fault protector (U7). If any of the SMBus interface signals exceed the MAX367's power supply rails, the MAX367 increases its resistance to prevent damage to the user's computer. A MAX865 dual charge pump (U6) and two zener diodes (D1 and D2) provide +7V and -3V supplies to the MAX367, thus allowing 0V and +5V signals to pass with a nominal resistance of 100Ω.

Bus Driving Circuitry

A 74HC05 open-drain inverter (U1) is used to pull down the SMBus interface signals. The 74HC08 (U3), 74HC74 (U4), and 74HC04 (U2) buffer the signal to the IBM PC and provide the capability to mask the ALERT interrupts, detect an externally generated start condition, and capture data sent by an external bus master. Interface connections are listed in Table 1 and Table 2.

Bus Monitoring Circuitry

Flip-flop U4A detects the start condition (falling edge of SMBDATA when SMBCLK is high). Flip-flop U4B detects the falling SMBCLK edge when enabled, and U1F holds SMBCLK low until the software releases it. To advance to the next data bit, the software uses U1A to assert and then release SMBCLK. A logic high at the input of U1A also resets flip-flop U4B. Because the IBM PC parallel port has a limited number of inputs, the start-detect circuit and the two alert inputs share a single interrupt input. The source of the interrupt is distinguished using U3A, U3B, and U3C.

Troubleshooting Guide

SYMPTOMS	CAUSE	SOLUTION
Can't Find the Interface Board	Board not connected to parallel printer port	Verify that the cable is a 25-pin parallel port I/O extension cable with a plug on one end and a socket on the other end. Verify that the cable is connected to a printer port, not a floppy disk, SCSI, or serial communications port.
Clock or Data Stuck Low	Board is connected to correct port, but SMBus is not functioning	Check power connections on the interface board. Check clock and data signal connections. Try operating the interface board without the companion Maxim evaluation kit—this should cause the address-not-acknowledged symptom described below.
Address Not Acknowledged	SMBus is OK, but no response at expected SMBus address	Verify that the companion board is connected to the MAXSMBus interface board. Verify that the companion board is powered. If the companion offers a choice of addresses, confirm that the software and hardware addresses match. Some devices only read the address select pins at device power-up.
Erratic Operation	Conflict with local printer driver	Disable print manager in Windows printer control panel. Disable printer driver.
	Operating system conflict	1) Use computer with commercially available BIOS. 2) Make a bootable floppy disk, remove unnecessary device drivers from A:\config.sys, and boot system from floppy.

Two-Wire Interface Board

Evaluates: MAX5SMBUS

Table 1. DB25 Connector Signals

PIN	NAME	FUNCTION
1	SPARE OUTPUT A	Spare output
2	$\overline{\text{SMBCLK_OUT}}$	When high, drives SMBCLK signal low
3	$\overline{\text{SMBDATA_OUT}}$	When high, drives SMBDATA signal low
4	SMBUS_OUT	When high, drives SMBSUS signal low
5	LOOPBACK	Loopback connection for port verification
6	$\overline{\text{MASK_ALERT1}}$	When high, allows $\overline{\text{ALERT1}}$ to trigger $\overline{\text{INT}}$ low
7	$\overline{\text{MASK_ALERT2}}$	When high, allows $\overline{\text{ALERT2}}$ to trigger $\overline{\text{INT}}$ low
8	$\overline{\text{MASK_START}}$	When high, allows a start condition to trigger $\overline{\text{INT}}$ low
9	CAPTURE_ENABLE	When high, enables slave / bus monitor circuitry. This circuit waits until SMBCLK is pulled low, and then it holds SMBCLK until the software resets it.
10	INT	Active low interrupt input
11	$\overline{\text{SMBDATA_IN}}$	When high, indicates that SMBDATA is low
12	$\overline{\text{SMBCLK_IN}}$	When high, indicates that SMBCLK is low
13	LOOPBACK	Loopback connection for port verification
14	SPARE OUTPUT B	Spare output
15	$\overline{\text{HOLDING_CLOCK}}$	When low, indicates that interface board is holding SMBCLK low
16	UNUSED	Not used
17	UNUSED	Not used
18-25	GND	Signal ground return

Two-Wire Interface Board

Table 2. Right-Angle Header P1 Signals

PIN	NAME	FUNCTION
1	DUT +5V	+5V at 20mA power supply to Maxim companion board
2	GND	Signal ground return
3	DUT SDA	SMBDATA interface signal
4	GND	Signal ground return
5	GND	Signal ground return
6	GND	Signal ground return
7	DUT SCL	SMBCLK interface signal
8	GND	Signal ground return
9	$\overline{\text{DUTSMB\SUS}}$	$\overline{\text{SMB\SUS}}$ interface signal
10	GND	Signal ground return
11	$\overline{\text{DUTSMBALERT}}$	Primary $\overline{\text{ALERT}}$ interface signal
12	GND	Signal ground return
13	$\overline{\text{DUTALERT2}}$	Secondary $\overline{\text{ALERT}}$ interface signal
14	GND	Signal ground return
15	SPARE OUTPUT A	Spare output from pin 1 of the DB25 connector
16	GND	Signal ground return
17	SPARE OUTPUT B	Spare output from pin 14 of the DB25 connector
18	GND	Signal ground return
19	GND	Signal ground return
20	RAW POWER	Unregulated, unprotected power-supply input to MAXSMBus interface board

Note: Odd-numbered pins are on the outer row. Even-numbered pins are on the inner row. All right-angle header signals pass through the MAX367 circuit protector, except 20.

Two-Wire Interface Board

Evaluates: MAXSMBUS

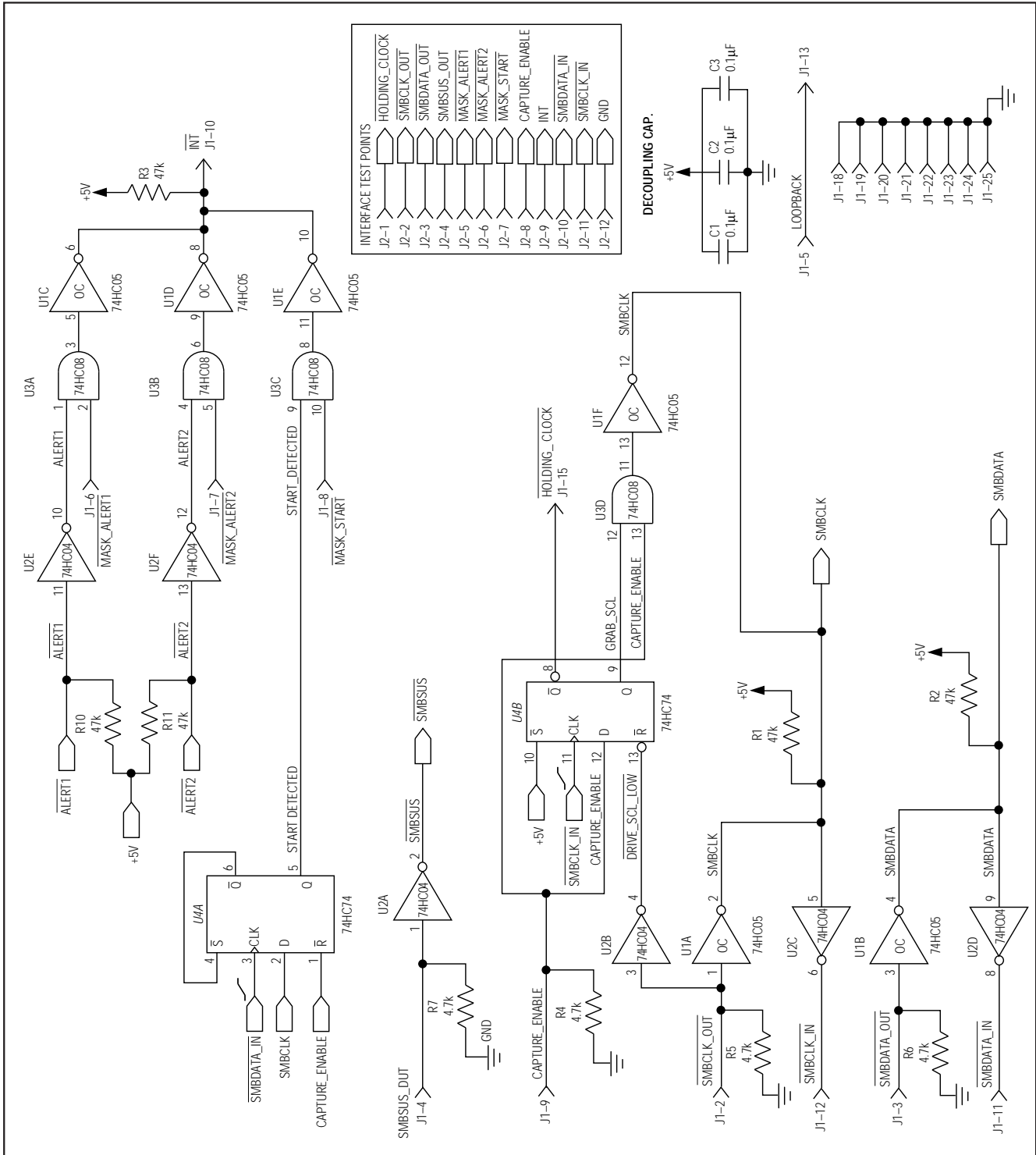

Figure 1. MAXSMBus Schematic

Two-Wire Interface Board

Evaluates: MAXSMBUS

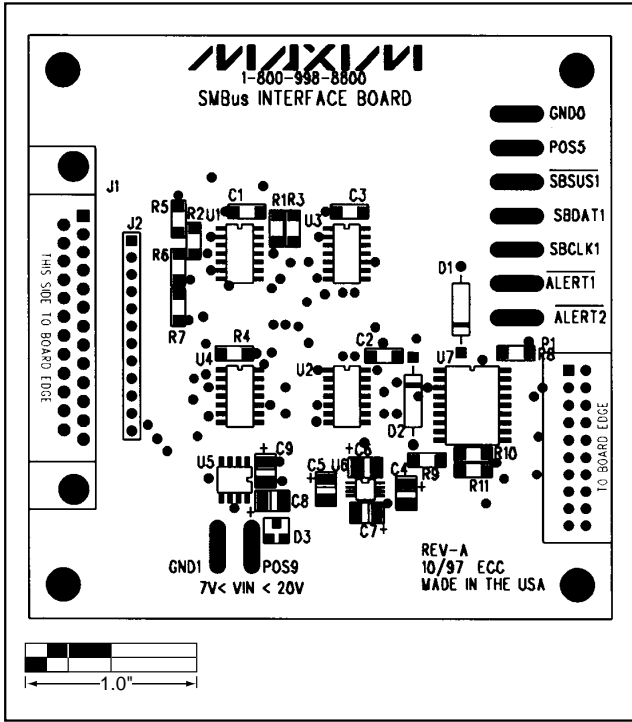

Figure 2. MAXSMBus Component Placement Guide

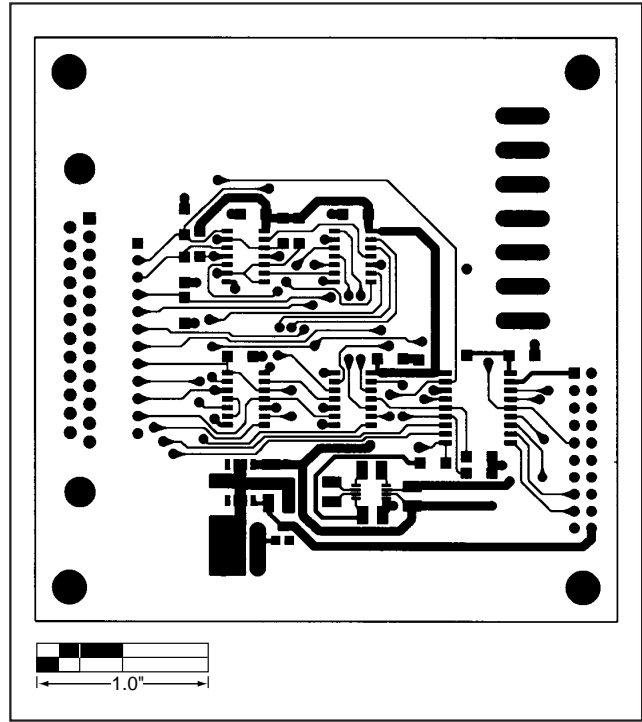

Figure 3. MAXSMBus PC Board Layout—Component Side

Two-Wire Interface Board

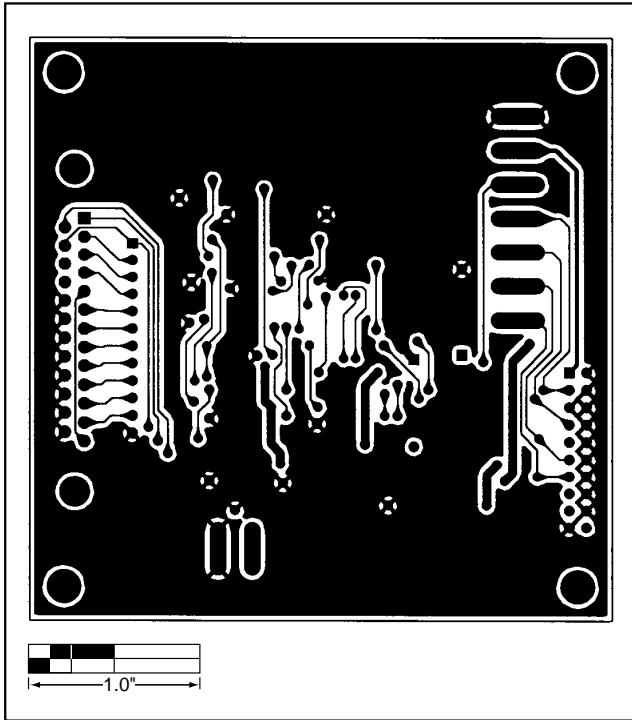

Figure 4. MAXSMBus PC Board Layout—Solder Side

Maxim cannot assume responsibility for use of any circuitry other than circuitry entirely embodied in a Maxim product. No circuit patent licenses are implied. Maxim reserves the right to change the circuitry and specifications without notice at any time.

8 _____ Maxim Integrated Products, 120 San Gabriel Drive, Sunnyvale, CA 94086 408-737-7600