

MAX14759/MAX14761/MAX14763

Above- and Below-the-Rails Low On-Resistance Analog Switches

General Description

The MAX14759/MAX14761/MAX14763 analog switches are capable of passing bipolar signals that are beyond their supply rails. These devices operate from a single +3.0V to +5.5V supply and support signals in the -25V to +25V range.

The MAX14759 is a single-pole/single-throw (SPST) analog switch, while the MAX14761 is a dual-SPST analog switch. The MAX14763 is a single-pole/double-throw (SPDT) analog switch.

The MAX14759 features 1Ω (max) on-resistance with a ±200nA (max) on-leakage current. The MAX14761/MAX14763 feature 2Ω (max) on-resistance with a ±100nA (max) on-leakage current. The low on-resistance and high bandwidth allow use in digital- and analog-signal switching applications.

The MAX14759/MAX14763 are available in an 8-pin (3mm x 3mm) TDFN package. The MAX14761 is available in a 10-pin (3mm x 3mm) TDFN package. These devices are specified over the -40°C to +85°C extended temperature range.

Ordering Information/Selector Guide appears at end of data sheet.

For related parts and recommended products to use with this part, refer to www.maxim-ic.com/MAX14759.related.

Benefits and Features

- ◆ **Simplify Power-Supply Requirements**
 - ◇ +3.0V to +5.5V Supply Range
 - ◇ -25V to +25V Signal Range
- ◆ **High Performance**
 - ◇ Low 1Ω (max) or 2Ω (max) On-Resistance
 - ◇ Low 2.4mΩ (typ) and 5.1mΩ (typ) R_{ON} Flatness
 - ◇ 500mA (max) Switch Current for MAX14759
 - ◇ Thermal Shutdown Protection
 - ◇ -40°C to +85°C Operating Temperature Range
 - ◇ High Bandwidth: 100MHz (typ) Insertion Loss
 - ◇ High-ESD Protection Up to 2kV
- ◆ **Save Board Space**
 - ◇ Small 8-Pin and 10-Pin TDFN Packages

Applications

Industrial Measurement Systems
Instrumentation Systems
RS-485 Termination Switching
CAN Bus Termination Switching
Opto-Relay Replacement
Medical Systems
ATE Systems
Audio Signal Routing and Switching

Functional Diagrams/Truth Tables

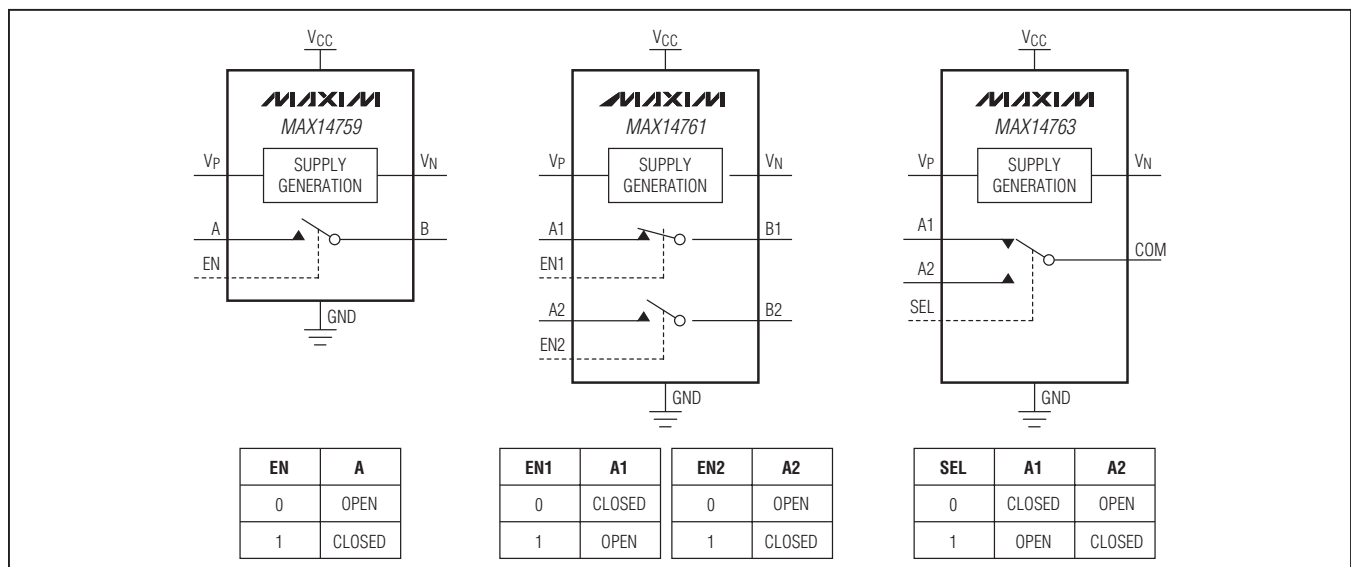

MAX14759/MAX14761/MAX14763

Above- and Below-the-Rails Low On-Resistance Analog Switches

ABSOLUTE MAXIMUM RATINGS

(All voltages referenced to GND, unless otherwise noted.)

V _{CC}	-0.3V to +6V
EN, EN1, EN2, SEL	-0.3V to + (V _{CC} + 0.3V)
A, B, A1, A2, B1, B2, COM	(V _N - 0.3V) to Lesser of (V _P + 0.3V) or (V _N + 52V)
V _P	-0.3V to Lesser of (+52V) or (V _N + 70V)
V _N	Greater of (V _{CC} - 40V) or (V _P - 70V) to +0.3V
V _P to V _N	-0.3V to +70V
Continuous Current Through Switch (MAX14759).....	±500mA

Continuous Current Through Switch

(MAX14761, MAX14763).....	±250mA
Continuous Power Dissipation (T _A = +70°C)	
8-Pin TDFN Package	
(derate 24.4mW/°C above +70°C).....	1951.2mW
10-Pin TDFN Package	
(derate 24.4mW/°C above +70°C).....	1951.2mW
Operating Temperature Range.....	-40°C to +85°C
Storage Temperature Range.....	-65°C to +160°C
Lead Temperature (soldering, 10s).....	+300°C
Soldering Temperature (reflow).....	+260°C

Stresses beyond those listed under "Absolute Maximum Ratings" may cause permanent damage to the device. These are stress ratings only, and functional operation of the device at these or any other conditions beyond those indicated in the operational sections of the specifications is not implied. Exposure to absolute maximum rating conditions for extended periods may affect device reliability.

PACKAGE THERMAL CHARACTERISTICS (Note 1)

8-Pin TDFN

Junction-to-Ambient Thermal Resistance (θ _{JA})	48°C/W
Junction-to-Case Thermal Resistance (θ _{JC}).....	8°C/W

10-Pin TDFN

Junction-to-Ambient Thermal Resistance (θ _{JA})	41°C/W
Junction-to-Case Thermal Resistance (θ _{JC}).....	9°C/W

Note 1: Package thermal resistances were obtained using the method described in JEDEC specification JESD51-7, using a four-layer board. For detailed information on package thermal considerations, refer to www.maxim-ic.com/thermal-tutorial.

ELECTRICAL CHARACTERISTICS

(V_{CC} = +3.0V to +5.5V, T_A = -40°C to +85°C, unless otherwise noted. Typical values are at V_{CC} = 5V and T_A = +25°C.) (Note 2)

PARAMETER	SYMBOL	CONDITIONS	MIN	TYP	MAX	UNITS
DC CHARACTERISTICS						
Power Supply Range	V _{CC}		3.0		5.5	V
Continuous Current Through Switch	I _A	(MAX14759)	-500		+500	mA
		(MAX14761/MAX14763)	-250		+250	
Supply Current	I _{CC}	V _{CC} ≤ 4.7V	V _{EN} = V _{CC}	4.1	10	mA
			V _{EN} = V _{CC} /2	4.1	10	
		V _{CC} > 4.7V	V _{EN} = V _{CC}	2.5	6	
			V _{EN} = V _{CC} /2	2.5	6	
Analog-Signal Range	V _{COM} , V _A , V _B	Switch open or closed	-25		+25	V
On-Resistance	R _{ON}	I _B = ±500mA, V _A = ±25V (MAX14759)		0.6	1	Ω
		I _{COM} or I _B = ±250mA, V _A = ±25V (MAX14761/MAX14763)		1.2	2	
On-Resistance Flatness	ΔR _{ON}	-25V < V _A < +25V, I _B = ±500mA (MAX14759)		2.4		mΩ
		-25V < V _A < +25V, I _B or I _{COM} = ±250mA (MAX14761/MAX14763)		5.1		
A, A1, A2 Off-Leakage Current	I _{A(OFF)}	V _A = +25V, V _B = 0V, Figure 1 (MAX14759)	-250		+250	nA
		V _A = +25V, V _{COM} or V _B = 0V, Figure 1 (MAX14761/MAX14763)	-250		+250	
COM, B, B1, B2 Off-Leakage Current	I _{COM(OFF)} , I _{B(OFF)}	V _{COM} or V _B = 15V, V _A = 0V, Figure 1 (MAX14759/MAX14763)	-100		+100	nA
		V _B = 15V, V _A = 0V, Figure 1 (MAX14761)	-100		+100	

MAX14759/MAX14761/MAX14763

Above- and Below-the-Rails Low On-Resistance Analog Switches

ELECTRICAL CHARACTERISTICS (continued)

($V_{CC} = +3.0V$ to $+5.5V$, $T_A = -40^{\circ}C$ to $+85^{\circ}C$, unless otherwise noted. Typical values are at $V_{CC} = 5V$ and $T_A = +25^{\circ}C$.) (Note 2)

PARAMETER	SYMBOL	CONDITIONS	MIN	TYP	MAX	UNITS
On-Leakage Current	I_{ON}	$V_A = \pm 25V$, B1, B2, or COM are unconnected, Figure 1 (MAX14759)	-200		+200	nA
		$V_A = \pm 25V$, B1, B2, or COM are unconnected, Figure 1 (MAX14761)	-100		+100	
		$V_A = \pm 25V$, B1, B2, or COM are unconnected, Figure 1 (MAX14763)	-250		+250	
DIGITAL LOGIC						
Input-Voltage Low	V_{IL}	$V_{CC} = 3.0V$			0.7	V
		$V_{CC} = 3.6V$			0.7	
		$V_{CC} = 4.5V$			0.8	
		$V_{CC} = 5.5V$			0.8	
Input-Voltage High	V_{IH}	$V_{CC} = 3.0V$	1.7			V
		$V_{CC} = 3.6V$	1.9			
		$V_{CC} = 4.5V$	2.0			
		$V_{CC} = 5.5V$	2.1			
Input Current	I_L		-1		+1	μA
AC CHARACTERISTICS						
Power-On Time	t_{PWRON}	$V_{A-} = \pm 10V$, $C_{VP} = C_{VN} = 1\mu F$, Note 3		320		ms
Enable Turn-On Time	t_{ON}	$V_{A-} = \pm 10V$, $R_L = 10k\Omega$, Figure 2 (MAX14759/MAX14761)		152	300	μs
		$V_{A-} = \pm 10V$, $R_L = 10k\Omega$, Figure 2 (MAX14763)		1.12	1.8	ms
Enable Turn-Off Time	t_{OFF}	$V_{A-} = \pm 10V$, $R_L = 10k\Omega$, Figure 2		300	1000	μs
Break-Before-Make Interval	t_{BBM}	$V_{A-} = 1V_{RMS}$, $R_L = 10k\Omega$, Figure 3 (MAX14763)		740		μs
Off-Isolation	V_{ISO}	$V_{A-} = 1V_{RMS}$, $f = 100kHz$, $R_L = 50\Omega$, $C_L = 15pF$, Figure 4		-77		dB
Crosstalk	V_{CT}	$R_S = R_L = 50\Omega$, $f = 100kHz$, $V_{COM} = 1V_{RMS}$, Figure 5 (MAX14763)		-83		dB
-3dB Bandwidth	BW	$R_S = 50\Omega$, $R_L = 50\Omega$, $V_{A-} = 1V_{P-P}$, Figure 6		100		MHz
Total Harmonic Distortion Plus Noise	THD+N	$R_S = R_L = 1k\Omega$, $f = 20Hz$ to $20kHz$		0.0012		%
Charge Injection	Q	$V_{A-} = GND$, $C_L = 1nF$, Figure 7		1370		pC
Input Capacitance	C_{IN}	At A, A1, A2, B, B1, B2, and COM pins		58		pF
THERMAL PROTECTION						
Thermal Shutdown Temperature	t_{HYST}			+154		$^{\circ}C$
Shutdown Temperature Hysteresis	t_{SHUT}			24		$^{\circ}C$
ESD PROTECTION						
All Pins		Human Body Model		± 2		kV

Note 2: All devices are 100% production tested at $T_A = +25^{\circ}C$. Specifications over operating temperature range are guaranteed by design.

Note 3: The power-on time is defined as the settling time for the charge pump's output to reach steady-state value within 1%.

MAX14759/MAX14761/MAX14763

Above- and Below-the-Rails Low On-Resistance Analog Switches

Test Circuits/Timing Diagrams

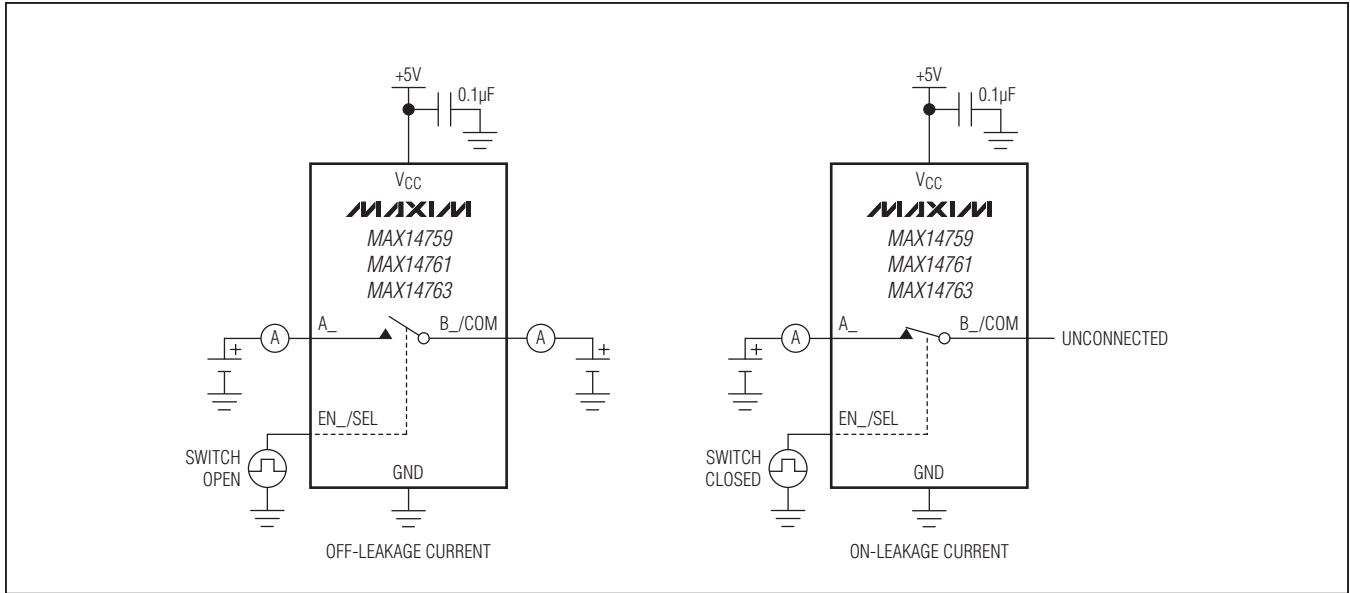

Figure 1. Leakage Current Measurement

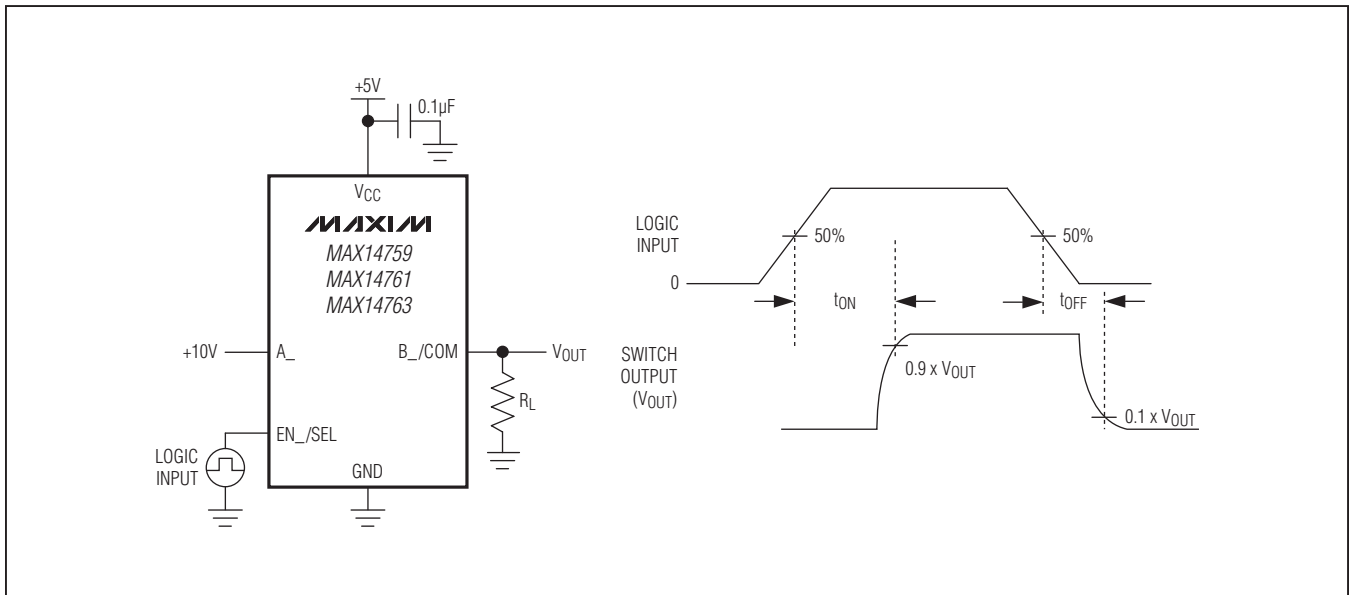

Figure 2. Switching Time

MAX14759/MAX14761/MAX14763

Above- and Below-the-Rails Low On-Resistance Analog Switches

Test Circuits/Timing Diagrams (continued)

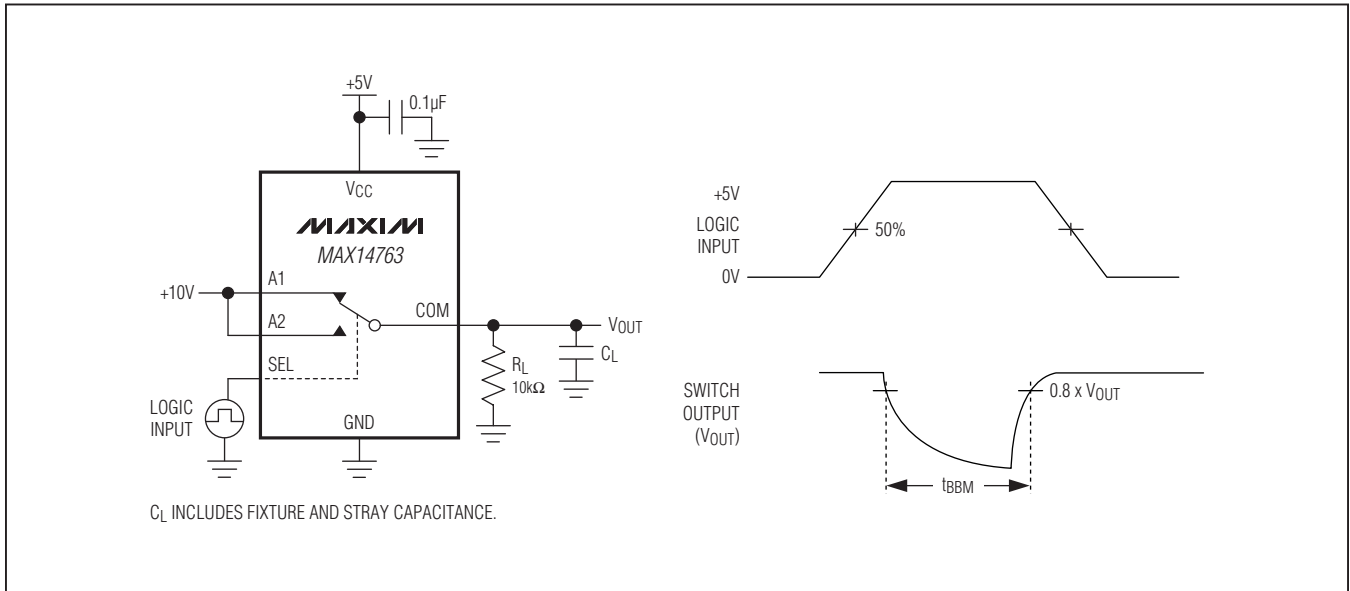

Figure 3. Break-Before-Make

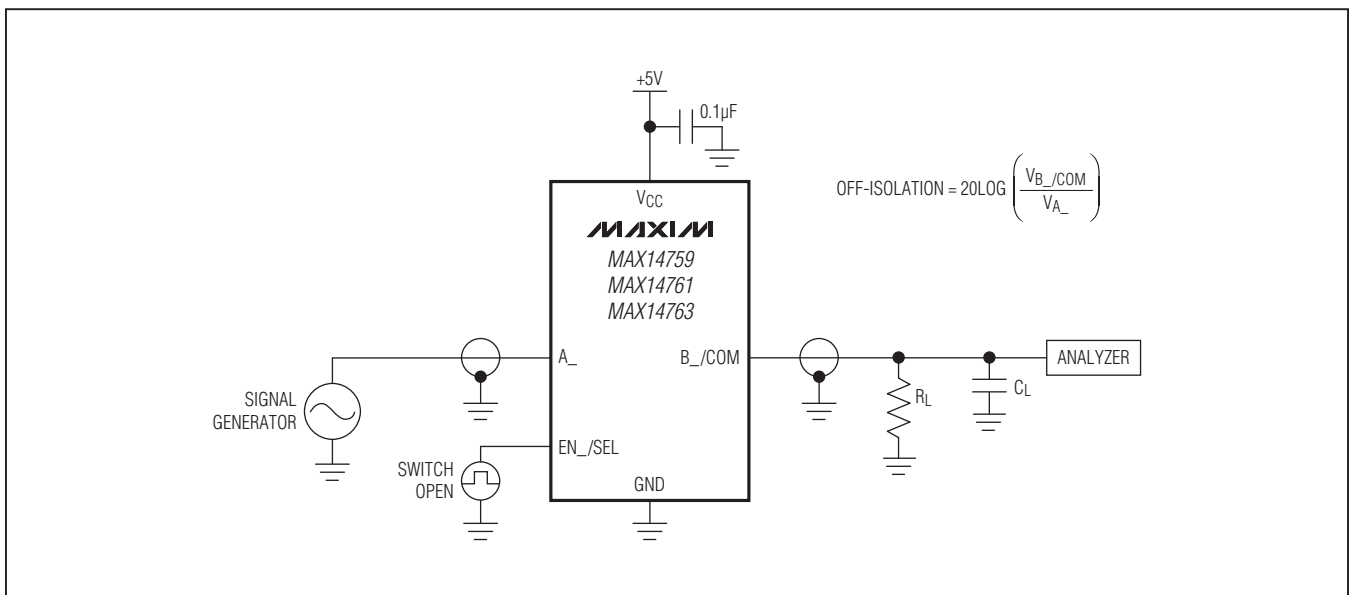

Figure 4. Off-Isolation

MAX14759/MAX14761/MAX14763

Above- and Below-the-Rails Low On-Resistance Analog Switches

Test Circuits/Timing Diagrams (continued)

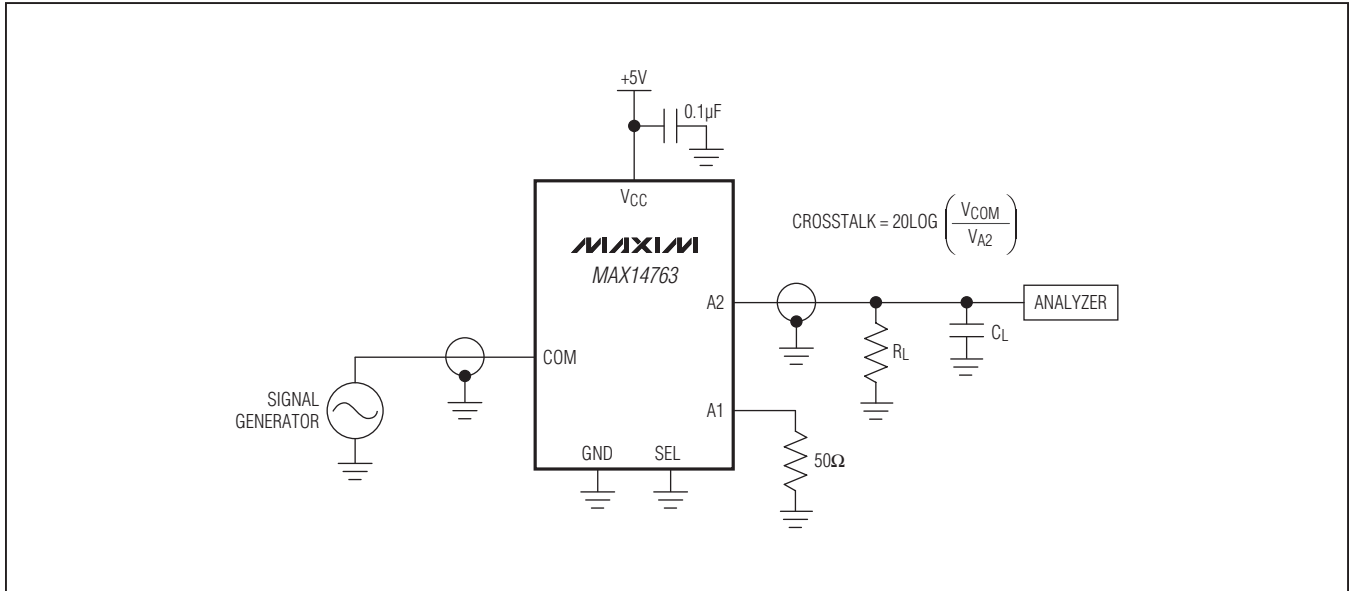

Figure 5. Crosstalk

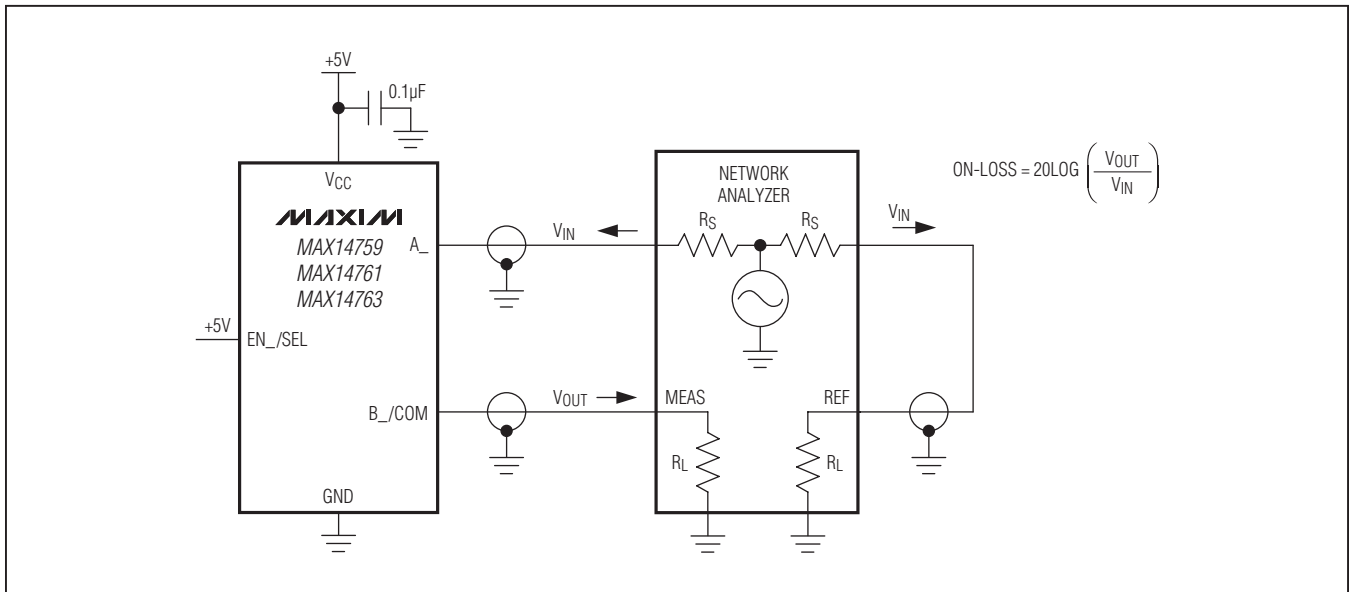

Figure 6. Insertion Loss

MAX14759/MAX14761/MAX14763

Above- and Below-the-Rails Low On-Resistance Analog Switches

Test Circuits/Timing Diagrams (continued)

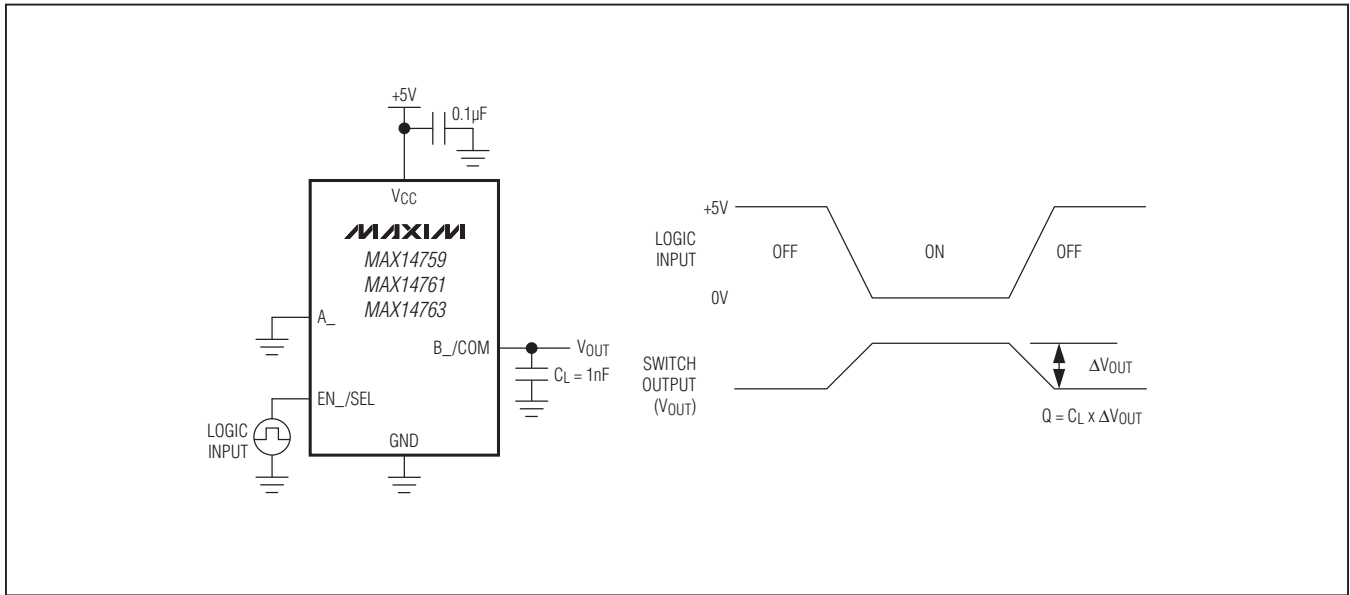
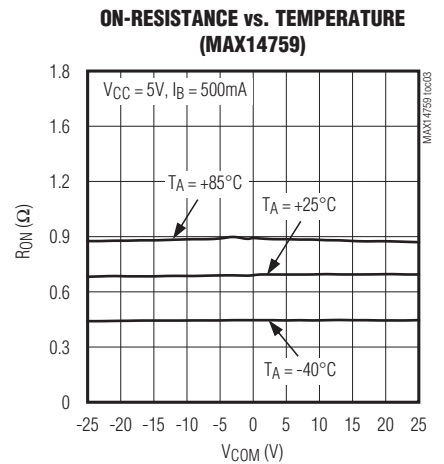
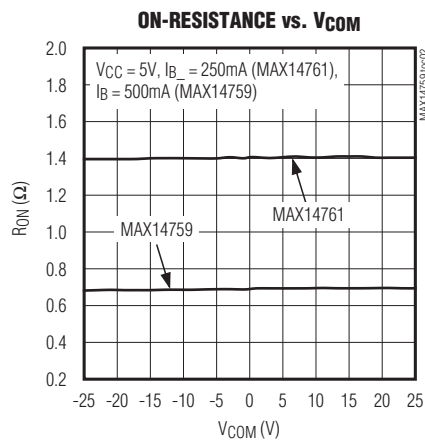
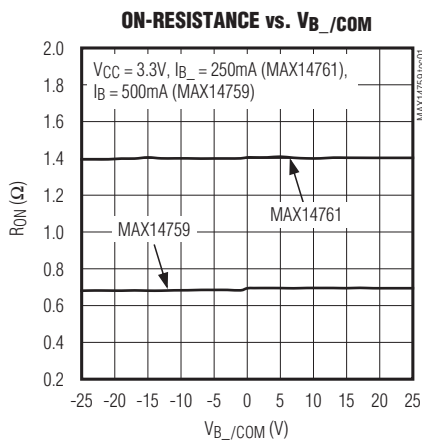

Figure 7. Charge Injection

Typical Operating Characteristics

($T_A = +25^\circ\text{C}$, unless otherwise noted.)



MAX14759/MAX14761/MAX14763

Above- and Below-the-Rails Low On-Resistance Analog Switches

Typical Operating Characteristics (continued)

($T_A = +25^\circ\text{C}$, unless otherwise noted.)

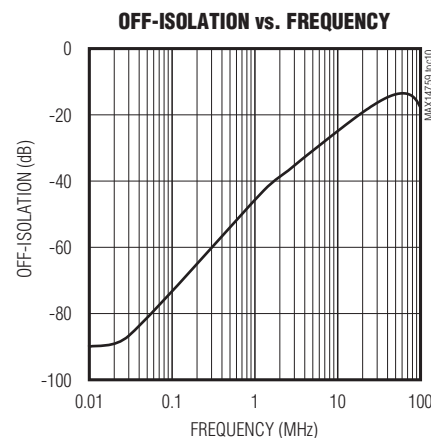
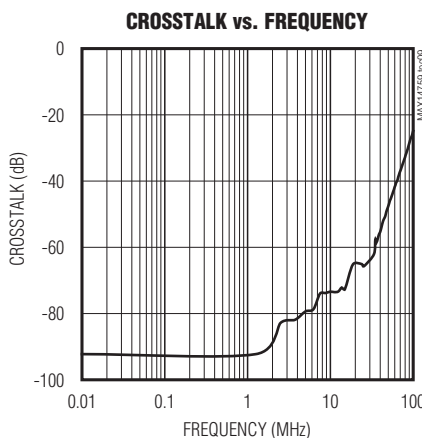
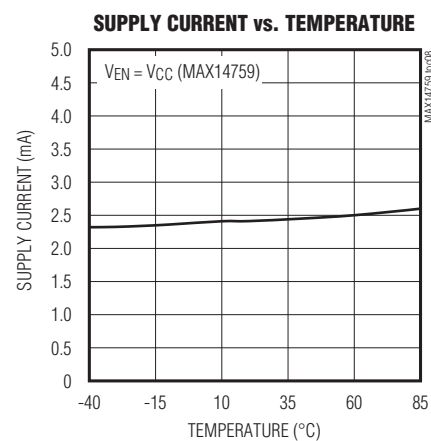
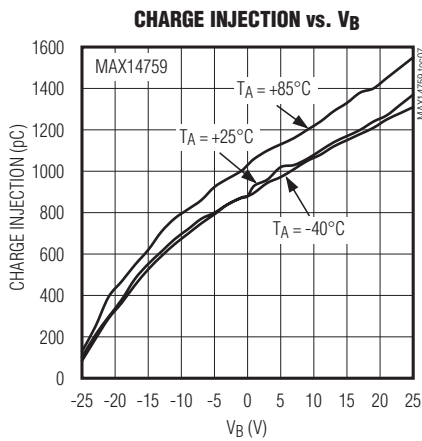
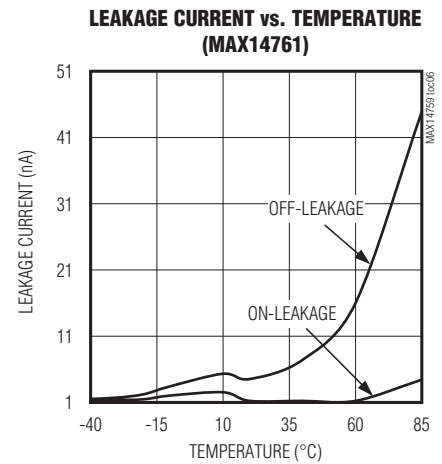
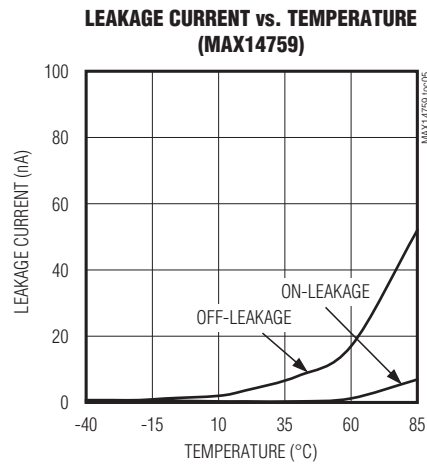
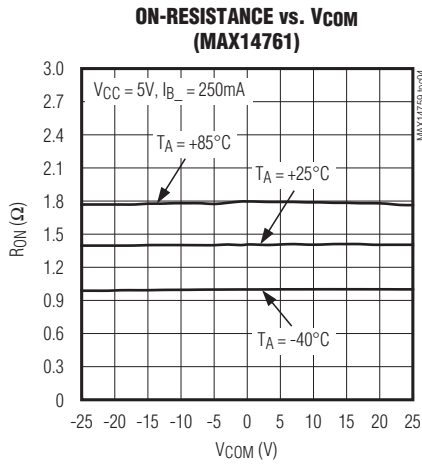

MAX14759/MAX14761/MAX14763

Above- and Below-the-Rails Low On-Resistance Analog Switches

Typical Operating Characteristics (continued)

($T_A = +25^\circ\text{C}$, unless otherwise noted.)

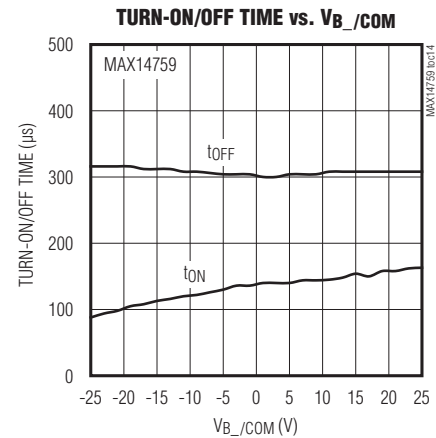
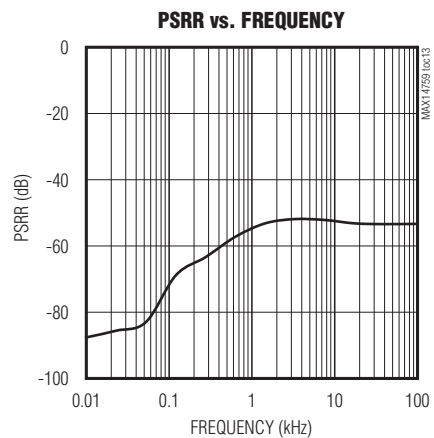
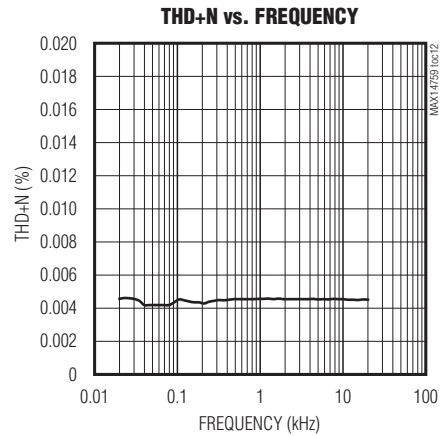
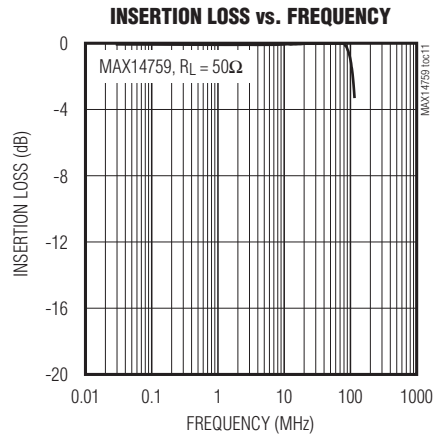

MAX14759/MAX14761/MAX14763

Above- and Below-the-Rails Low On-Resistance Analog Switches

Pin Configurations

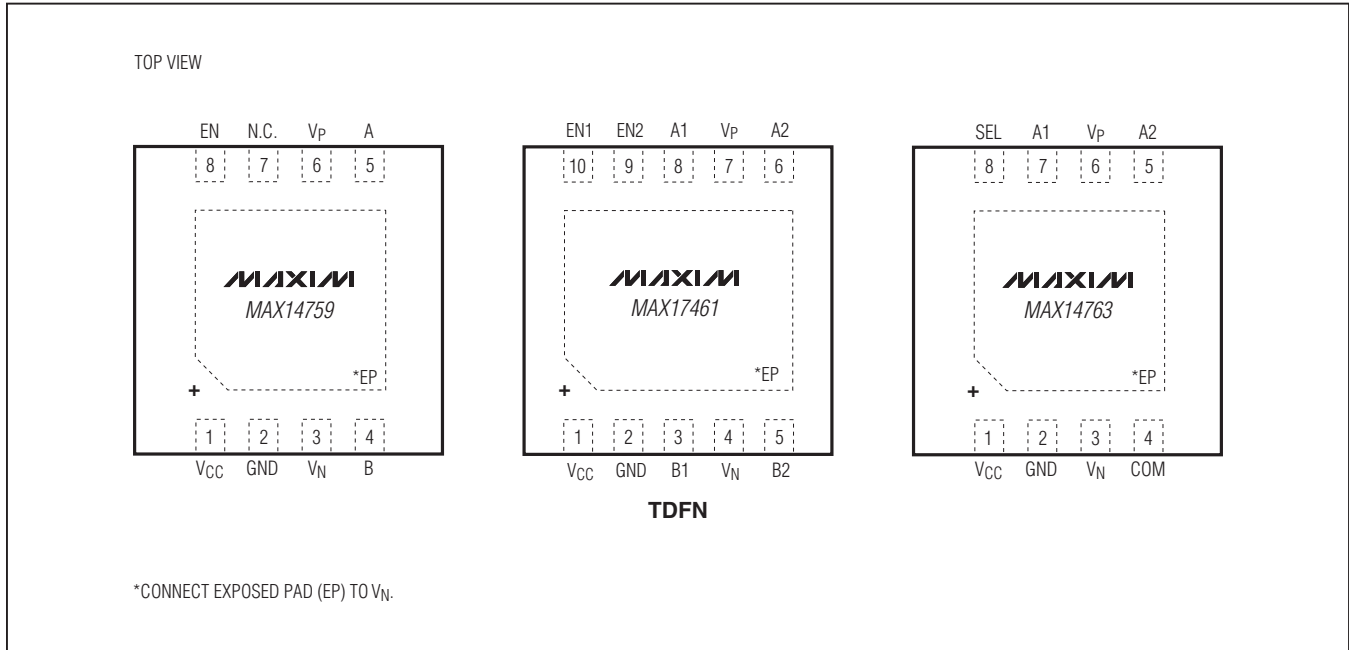

Pin Description

PIN			NAME	FUNCTION
MAX14759	MAX14761	MAX14763		
1	1	1	V_{CC}	Positive-Supply Voltage Input. Bypass V_{CC} to GND with a 0.1 μF ceramic capacitor placed as close as possible to the device.
2	2	2	GND	Ground
3	4	3	V_N	Negative Voltage Output. Bypass V_N to GND with a 1 μF ceramic capacitor placed as close as possible to the device.
4	—	—	B	Analog Switch Common Terminal
—	—	4	COM	Analog Switch Common Terminal
5	—	—	A	Analog Switch Normally Open Terminal
6	7	6	V_P	Positive Voltage Output. Bypass V_P to GND with a 1 μF ceramic capacitor placed as close as possible to the device.
7	—	—	N.C.	No Connection. Leave unconnected.
8	—	—	EN	Switch Control Input. Drive EN high to close the switch or drive EN low to open the switch.
—	8	7	A1	Analog Switch 1 Normally Closed Terminal

MAX14759/MAX14761/MAX14763

Above- and Below-the-Rails Low On-Resistance Analog Switches

Pin Description (continued)

PIN			NAME	FUNCTION
MAX14759	MAX14761	MAX14763		
—	3	—	B1	Analog Switch 1 Common Terminal
—	6	5	A2	Analog Switch 2 Normally Open Terminal
—	5	—	B2	Analog Switch 2 Common Terminal
—	10	—	EN1	Switch 1 Control Input. Drive EN1 high to open switch 1 or drive EN1 low to close switch 1.
—	9	—	EN2	Switch 2 Control Input. Drive EN2 high to close switch 2 or drive EN2 low to open switch 2.
—	—	8	SEL	Switch Control Input. Drive SEL low to connect the COM terminal to A1 or drive SEL high to connect the COM terminal to A2.
—	—	—	EP	Exposed Pad. Internally connected to V_N ; not intended as an electrical connection. Leave exposed pad unconnected.

Detailed Description

The MAX14759/MAX14761/MAX14763 are analog switches capable of handling signals above and below their rails. These devices operate from a single +3.0V to +5.5V supply and support signals in the -25V to +25V range. The low on-resistance and high bandwidth allow for use in digital- and analog-signal switching applications.

Analog Signal Range

The devices switch signals in the range from -25V to +25V that are above and below their rails. The on-resistance for these devices exhibit a high degree of flatness of 2.4m Ω (MAX14759 typ) and 5.1m Ω (MAX14761/MAX14763 typ) over the whole input voltage range of -25V to +25V. The analog switches allow bidirectional current flow, so A, A1, A2, B, B1, B2, and COM can be used as either inputs or outputs.

Bypass Capacitors

Bias stabilizing capacitors are required on the V_P and V_N pins. 1 μ F ceramic capacitors are suggested for effective operation. V_P and V_N are not intended as a power supply for other circuitry.

Applications Information

Power-Up Conditions

Ensure that negative signals are not present on the A₋, B₋, or COM inputs until 1 second has passed after applying V_{CC} .

Differential Termination Resistor Switch

The MAX14759 can be used to switch a differential termination resistor in or out. In RS-485 and CAN applications, both ends of high-speed transmission lines require termination. [Figures 8](#) and [9](#) show an application of RS-485 and CAN termination using two equal resistors. These switches support RS-485's high -7V to +12V common-mode range.

In RS-232/RS-485 multiprotocol applications, the MAX14759 can be used for switching in the line-terminating resistors for RS-485 usage, and can disable the termination resistor for RS-232 operation, as shown in [Figure 10](#).

The MAX14761 is ideal for switching in fail-safe biasing resistors in RS-485 applications, as shown in [Figures 11](#) and [12](#).

MAX14759/MAX14761/MAX14763

Above- and Below-the-Rails Low On-Resistance Analog Switches

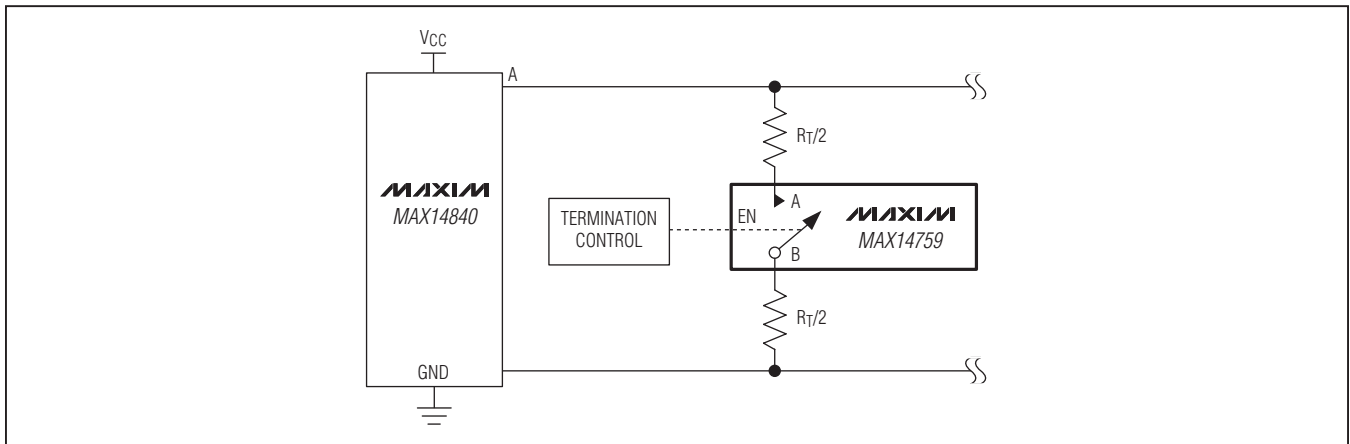

Figure 8. RS-485 Termination Switch

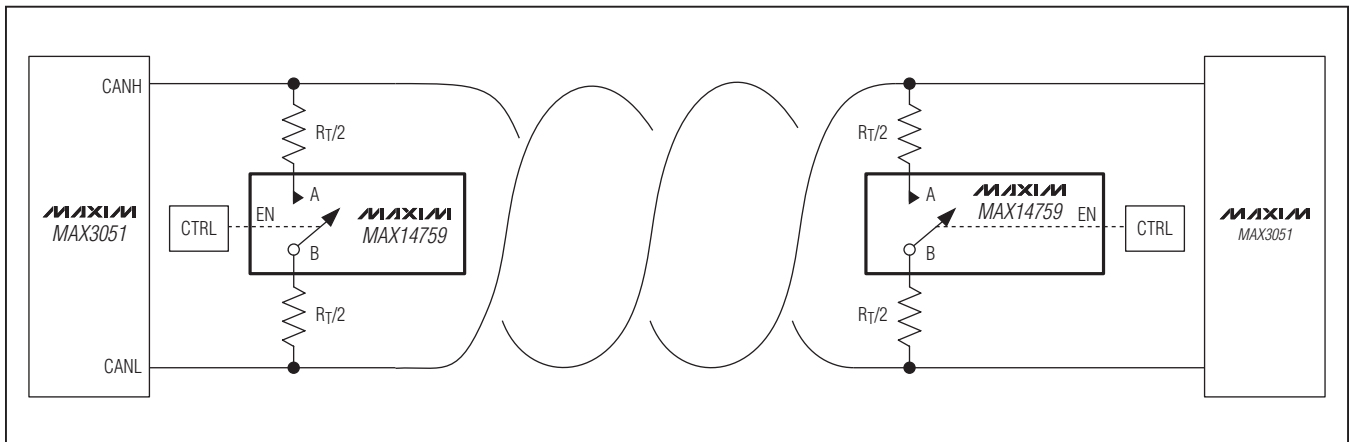

Figure 9. CAN Termination Switch

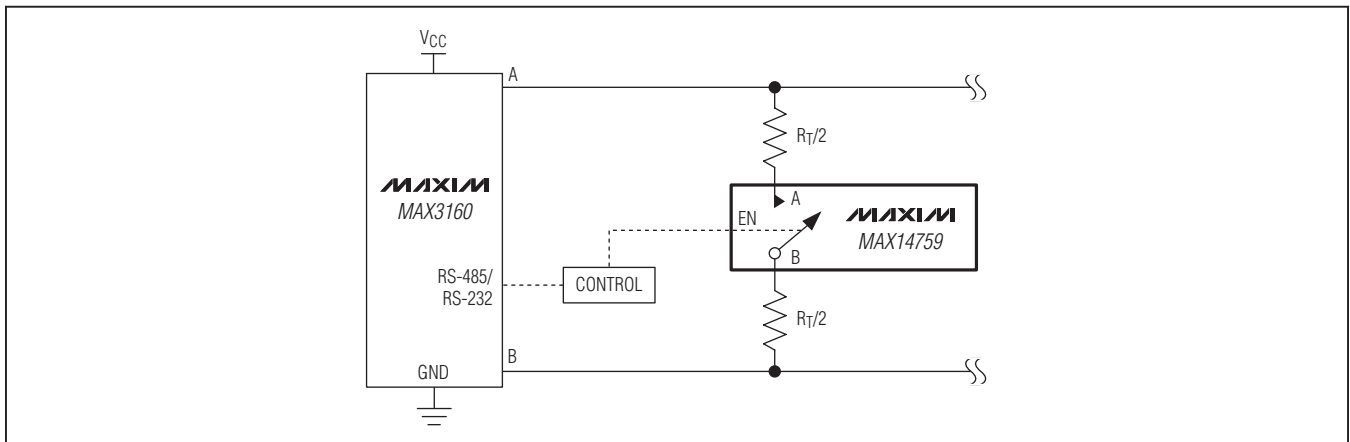

Figure 10. Multiprotocol Termination Switch

MAX14759/MAX14761/MAX14763

Above- and Below-the-Rails Low On-Resistance Analog Switches

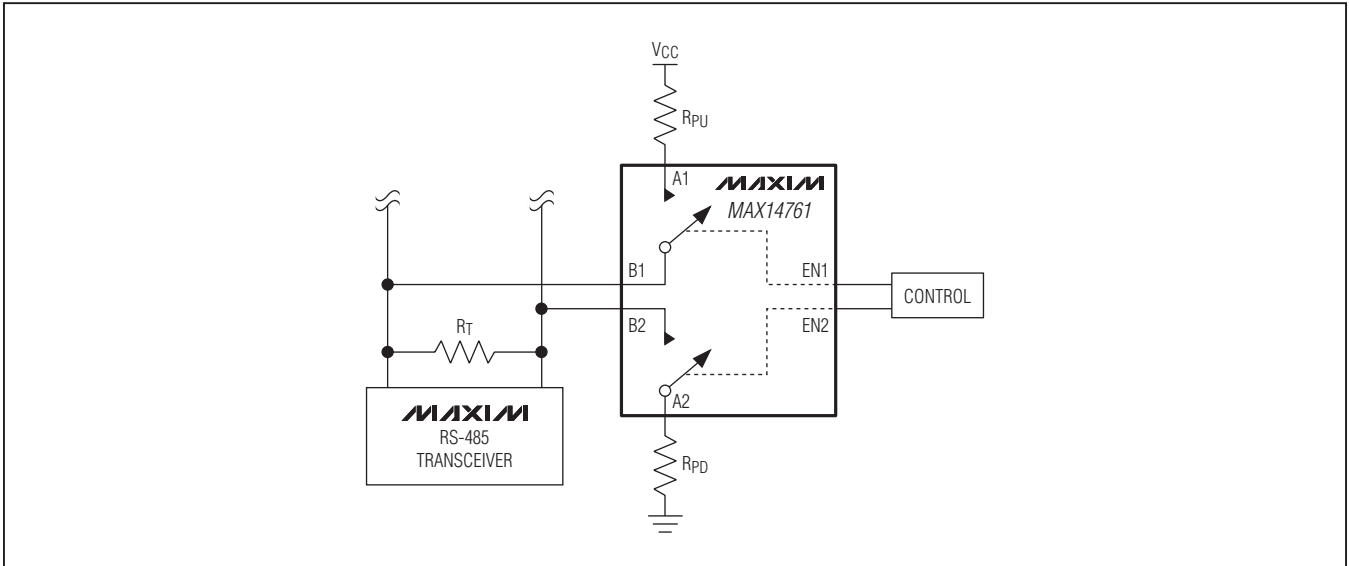

Figure 11. Pullup and Pulldown Resistance Switch

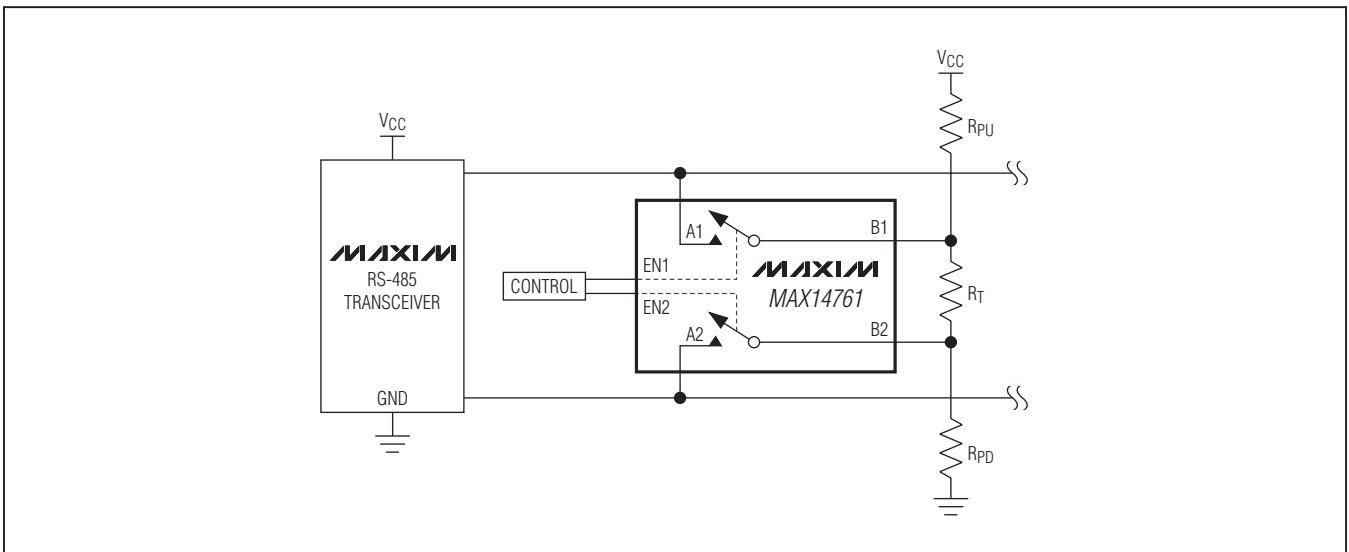

Figure 12. Fail-Safe Biasing Network Switch

MAX14759/MAX14761/MAX14763

Above- and Below-the-Rails Low On-Resistance Analog Switches

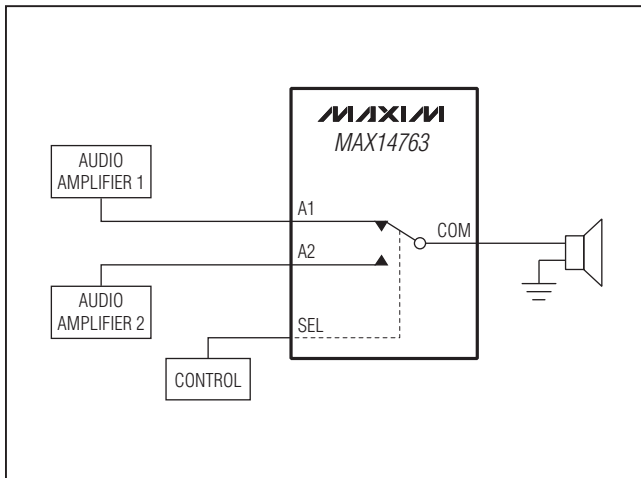

Figure 13. Single-Ended Amplifier Switching

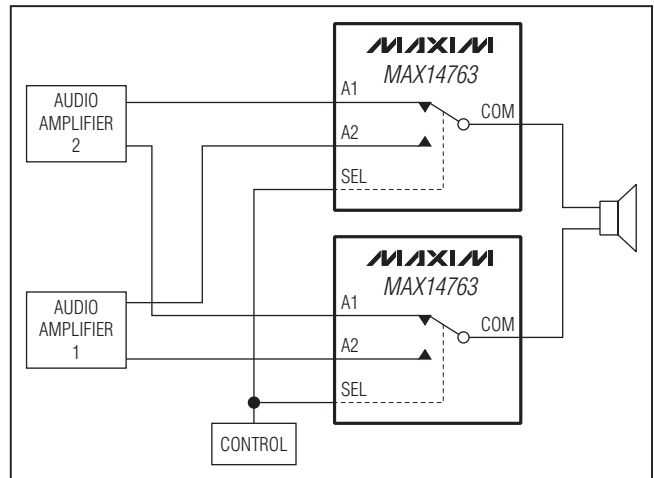

Figure 14. Differential Amplifier Switching

Audio Amplifier Switch

The MAX14763 is used for selecting between audio amplifier sources to drive loudspeaker applications (Figures 13 and 14.)

MAX14759/MAX14761/MAX14763

Above- and Below-the-Rails Low On-Resistance Analog Switches

Ordering Information/Selector Guide

PART	TEMP RANGE	PIN-PACKAGE	FUNCTION	R _{ON} (MAX) (Ω)
MAX14759ETA+	-40°C to +85°C	8 TDFN-EP*	1 x SPST	1
MAX14761ETB+	-40°C to +85°C	10 TDFN-EP*	2 x SPST	2
MAX14763ETA+	-40°C to +85°C	8 TDFN-EP*	1 x SPDT	2

+Denotes a lead(Pb)-free/RoHS-compliant package.

*EP = Exposed pad.

Chip Information

PROCESS: BiCMOS

Package Information

For the latest package outline information and land patterns (footprints), go to www.maxim-ic.com/packages. Note that a "+", "#", or "-" in the package code indicates RoHS status only. Package drawings may show a different suffix character, but the drawing pertains to the package regardless of RoHS status.

PACKAGE TYPE	PACKAGE CODE	OUTLINE NO.	LAND PATTERN NO.
8 TDFN	T833+2	21-0137	90-0059
10 TDFN	T1033+1	21-0137	90-0003

MAX14759/MAX14761/MAX14763

Above- and Below-the-Rails Low On-Resistance Analog Switches

Revision History

REVISION NUMBER	REVISION DATE	DESCRIPTION	PAGES CHANGED
0	9/11	Initial release	—

Maxim cannot assume responsibility for use of any circuitry other than circuitry entirely embodied in a Maxim product. No circuit patent licenses are implied. Maxim reserves the right to change the circuitry and specifications without notice at any time. The parametric values (min and max limits) shown in the Electrical Characteristics table are guaranteed. Other parametric values quoted in this data sheet are provided for guidance.

Maxim Integrated Products, 120 San Gabriel Drive, Sunnyvale, CA 94086 408-737-7600 _____ 16