



MAX14521E Evaluation Kit

General Description

The MAX14521E evaluation kit (EV kit) provides a proven design to evaluate the MAX14521E quad, high-voltage EL lamp drivers. The EV kit also includes Windows® 2000/XP- and Windows Vista®-compatible software that provides a simple graphical user interface (GUI) for exercising the features of the MAX14521E.

The MAX14521E EV kit PCB comes with a MAX14521EETG+ installed.

Ordering Information

PART	TYPE
MAX14521EEVKIT+	EV Kit

+Denotes lead(Pb)-free and RoHS compliant.

Features

- ◆ Wide 2.7V to 5.5V Supply Range
- ◆ Windows 2000/XP- and Windows Vista (32-Bit)-Compatible Software
- ◆ USB-PC Connection (Cable Included)
- ◆ USB Powered
- ◆ Lead(Pb)-Free and RoHS Compliant
- ◆ I²C Interface Terminals
- ◆ Proven PCB Layout
- ◆ Fully Assembled and Tested

Evaluates: MAX14521E

Component List

DESIGNATION	QTY	DESCRIPTION
C1, C5–C9, C17, C18, C37	9	0.1µF ±20%, 16V X7R ceramic capacitors (0603) Murata GRM188R71C104K
C2, C11, C38, C40	4	10µF ±20%, 16V X5R ceramic capacitors (1206) Murata GRM31CR61C106M
C3	1	3300pF ±20%, 250V X5R ceramic capacitor (0805) Murata GRM21AR72E332K
C4	1	0.033µF ±10%, 16V-min X5R ceramic capacitor (0603) Taiyo Yuden EMK107BJ333KA
C10, C39	2	1µF ±10%, 16V X5R ceramic capacitors (0603) TDK C1608X5R1C105K
C12	1	0.01µF ±10%, 16V X7R ceramic capacitor (0603) Murata GRM188R71C103K
C13	1	330pF ±10%, 50V X7R ceramic capacitor (0402) Murata GRM155R71H331K
C15, C16	2	10pF ±5%, 50V C0G ceramic capacitors (0603) Murata GRM1885C1H100J
C30, C31	2	22pF ±5%, 50V C0G ceramic capacitors (0603) Murata GRM1885C1H220J

DESIGNATION	QTY	DESCRIPTION
D1	1	200V, 50ns fast-recovery diode (SOD323) Diodes, Inc BAV21WS (Top Mark: T3)
EL1–EL4, COM (x4 wires)	8	Wire assembly with micro alligator clip (steel, 5A) and vinyl insulator (black) Mueller BU-34 Mueller BU-36-0
H1	1	8-pin header
J1	1	USB type-B right-angle female receptacle
J2	1	Surface-mount 1/8in stereo headset jack
J3	0	Not installed
JU1–JU4	4	3-pin headers
JU5–JU8	0	Not installed, headers—shorted with PCB trace
L1	1	Tapped inductor, 1:7 ratio, 150µH total; 2.3µH primary, 115µH secondary (3mm x 3mm) Coilcraft GA3250-AL
L2	1	Ferrite bead TDK MMZ1608R301A (0603)
LED1	1	Red LED (T1-3/4)
R1, R2	2	27Ω ±5% resistors (0603)

Windows and Windows Vista are registered trademarks of Microsoft Corp.



MAX14521E Evaluation Kit

Component List (continued)

DESIGNATION	QTY	DESCRIPTION
R3	1	1.5k Ω \pm 5% resistor (0603)
R4	1	470 Ω \pm 5% resistor (0603)
R5	1	2.2k Ω \pm 5% resistor (0603)
R6	1	10k Ω \pm 5% resistor (0603)
R7, R8	2	4.7k Ω \pm 5% resistors 0603)
R9	1	33k Ω \pm 5% resistor (0603)
R10	1	330 Ω \pm 5% resistor (0603)
R11	1	20 Ω \pm 5% resistor (0402)
R19–R23	0	Not installed, resistors—short (PC trace) (0402)
U1	1	Quad, high-voltage EL lamp drivers with I ² C interface (24 TQFN-EP*) Maxim MAX14521EETG+
U2	1	2.5V regulator (5 SC70) Maxim MAX8511EXK25+T (Top Mark: ADV)
U3	1	3.3V regulator (5 SC70) Maxim MAX8511EXK33+T (Top Mark: AEI)

DESIGNATION	QTY	DESCRIPTION
U4	1	Microcontroller (68 QFN-EP*) Maxim MAXQ2000-RAX+
U5	1	UART-to-USB converter (32 TQFP-L) FTDI FT232BL
U6	1	93C46 type 3-wire EEPROM (8 SO) 16-bit architecture Atmel AT93C46A-10SU-2.7
Y2	1	16MHz crystal (HCM49) Hong Kong X'tals SSM1600000E18FAF
Y3	0	Not installed, crystal
Y4	1	6MHz crystal (HCM49) Hong Kong X'tals SSL6000000E18FAF
—	4	Shunts
—	1	USB high-speed A-to-B cables, 6ft
—	1	PCB: MAX14521E Evaluation Kit+

*EP = Exposed pad.

Component Suppliers

SUPPLIER	PHONE	WEBSITE
Coilcraft, Inc.	847-639-6400	www.coilcraft.com
Diodes, Inc.	805-446-4800	www.diodes.com
Hong Kong X'tals Ltd.	852-35112388	www.hongkongcrystal.com
Murata Electronics North America, Inc.	770-436-1300	www.murata-northamerica.com
Taiyo Yuden	800-348-2496	www.t-yuden.com
TDK Corp.	847-803-6100	www.component.tdk.com

Note: Indicate that you are using the MAX14521E when contacting these component suppliers.

MAX14521E EV Kit Files

FILE	DESCRIPTION
MAX14521E.EXE	Application program
FTD2XX.INF	USB device driver file
UNINST.INI	Uninstalls the EV kit software
USB_Driver_Help.PDF	USB driver installation help file

MAX14521E Evaluation Kit

Evaluates: MAX14521E

Quick Start

Recommended Equipment

- MAX14521E EV kit (USB cable included)
- A user-supplied Windows 2000/XP- or Windows Vista-compatible PC with a spare USB port
- DC power supply for VDD ($2.7V < VDD < 5.5V$)
- DC power supply for VBAT ($VBAT < 13.2V$)
- Up to four electroluminescent (EL) lamp elements

Note: In the following sections, software-related items are identified by bolding. Text in **bold** refers to items directly from the EV kit software. Text in **bold and underlined** refers to items from the Windows operating system.

Procedure

The MAX14521E EV kit is fully assembled and tested. Follow the steps below to verify board operation:

- 1) Visit www.maxim-ic.com/evkitsoftware to download the latest version of the EV kit software, 14521Rxx.ZIP. Save the EV kit software to a temporary folder and uncompress the ZIP file.
- 2) Install the EV kit software on your computer by running the 14521Rxx.msi program inside the temporary folder. The program files are copied and icons are created in the Windows **Start | Programs** menu.
- 3) Verify that all jumpers (JU1–JU8) are in their default positions, as shown in Table 1.
- 4) Connect the external power supplies to VDD and VBAT. (**Note:** For convenience, the EV kit optionally can be configured to draw VDD and VBAT power from the 5V bus of the USB port.)
- 5) Connect an EL lamp between alligator clips EL1 and COM.
- 6) Optionally, up to three additional lamps can be connected between EL2-COM, EL3-COM, and EL4-COM.
- 7) Double check that none of the EL1–EL4 outputs are shorted to COM.
- 8) Connect the USB cable from the PC to the EV kit board. A **Building Driver Database** window pops up in addition to a **New Hardware Found** message when installing the USB driver for the first time. If you do not see a window that is similar to the one described above after 30s, remove the USB cable from the board and reconnect it. Administrator privileges are required to install the USB device driver on Windows 2000/XP/Vista.

Table 1. MAX14521E EV Kit Jumper Descriptions (JU1–JU8)

JUMPER	SIGNAL	SHUNT POSITION	DESCRIPTION
JU1	VBAT	1-2	Power VBAT from USB 5V supply
		2-3*	Power VBAT from external user-supplied power supply
JU2	VDD	1-2	Power VDD from USB 5V supply
		2-3*	Power VDD from external user-supplied power supply
JU3	A0	1-2*	A0 = VDD; determines I ² C device address (see Table 2)
		2-3	A0 = GND; determines I ² C device address (see Table 2)
JU4	A1	1-2*	A1 = VDD; determines I ² C device address (see Table 2)
		2-3	A1 = GND; determines I ² C device address (see Table 2)
JU5	SDA	Not installed*	SDA connected to on-board I ² C bus
		PCB trace cut open	SDA must be connected to an external I ² C bus
JU6	SCL	Not installed*	SCL connected to on-board I ² C bus
		PCB trace cut open	SCL must be connected to an external I ² C bus
JU7	SDA	Not installed*	SDA connected to on-board pullup resistor
		PCB trace cut open	SDA pullup resistor must be provided externally
JU8	SCL	Not installed*	SCL connected to on-board pullup resistor
		PCB trace cut open	SCL pullup resistor must be provided externally

*Default position.

MAX14521E Evaluation Kit

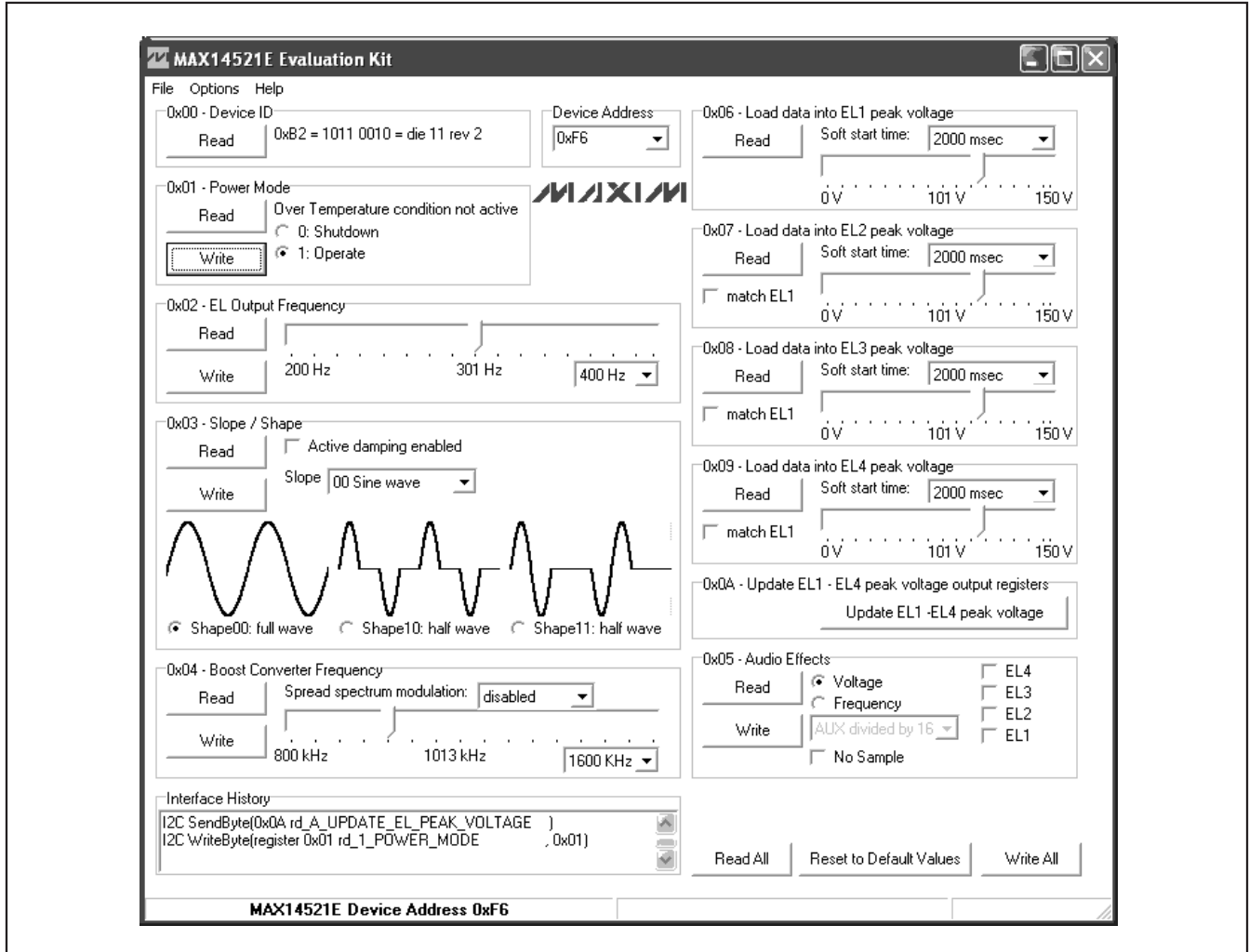

Figure 1. MAX14521E EV Kit Software Main Window

- 9) Follow the directions of the **Add New Hardware Wizard** to install the USB device driver. Choose the **Search for the best driver for your device** option. Specify the location of the device driver to be **C:\Program Files\Maxim MAX14521EEVKIT** (default installation directory) using the **Browse** button. During device driver installation, Windows may show a warning message indicating that the device driver Maxim uses does not contain a digital signature. This is not an error condition and it is safe to proceed with installation. Refer to the **USB_Driver_Help.PDF** document included with the software for additional information.
- 10) Start the MAX14521E EV kit software by opening its icon in the **Start | Programs** menu. The EV kit software main window appears, as shown in Figure 1.
- 11) The EV kit software automatically connects to the EV kit board and searches for the MAX14521E device address. The default jumper configuration sets device address 0xF6.
- 12) In the software, press the **Reset to Default Values** button. The MAX14521E registers are written to configure lamp frequency (300Hz), boost switching frequency (1000kHz), output voltage (100V peak), and power-mode is shut down.

MAX14521E Evaluation Kit

Evaluates: MAX14521E

- 13) In the **0x01 - Power Mode** group box, select the **1: Operate** radio button and press the **Write** button. The EL outputs power up using soft-start.
- 14) When changing the EL1–EL4 output peak voltage or soft-start time, two steps are required. The software automatically writes the corresponding registers 0x06–0x09. Multiple EL registers may be changed. The software displays a **“Need Update”** message inside the **0x0A - Update EL1 - EL4 peak voltage output registers** group box. Pressing the **Update EL1-EL4 peak voltage** button sends the update command, and the register 0x06–0x09 values become effective on the EL1–EL4 output pins.
- 15) The EV kit software can match the EL2, EL3, and EL4 outputs to the configuration of the EL1 output.

__Detailed Description of Software

The main window of the evaluation software (Figure 1) shows the MAX14521E device registers. Each individual register has its own **Read** and **Write** buttons. All registers are affected by the **Read All**, **Reset to Default Values**, and **Write All** buttons. Refer to the MAX14521E IC data sheet for detailed information about the device registers.

__Detailed Description of Hardware

The MAX14521E EV kit provides a proven layout for the MAX14521E. I²C-interface pads and easy-to-use USB-PC connection are included on the EV kit.

The microcontroller circuitry (U2–U6) is equivalent to Maxim’s MAXQ2000-based MINIQUSB board.

User-Supplied I²C Interface

To use the MAX14521E EV kit with a user-supplied I²C interface, first cut the JU5 and JU6 default traces, disconnecting SDA and SCL from the on-board microcontroller. If the user-supplied I²C bus provides its own SCL/SDA pullup resistors, then disable on-board pullup resistors R7 and R8 by cutting the JU7 and JU8 default traces. Next, apply your own 2.7V to 5.5V power supply between the EXT_VDD and GND pads. Lastly, connect your SCL and SDA signals to the corresponding SDA and SCL test points on header H1 on the MAX14521E EV kit board.

Table 2. I²C Device Address Selection (JU3, JU4)

SHUNT POSITION (JU4)	A1 PIN	SHUNT POSITION (JU3)	A0 PIN	DEVICE ADDRESS
2-3	GND	2-3	GND	1111 000 R/W
2-3	GND	1-2	VDD	1111 001 R/W
1-2	VDD	2-3	GND	1111 010 R/W
1-2*	VDD	1-2*	VDD	1111 011 R/W

*Default position.

MAX14521E Evaluation Kit

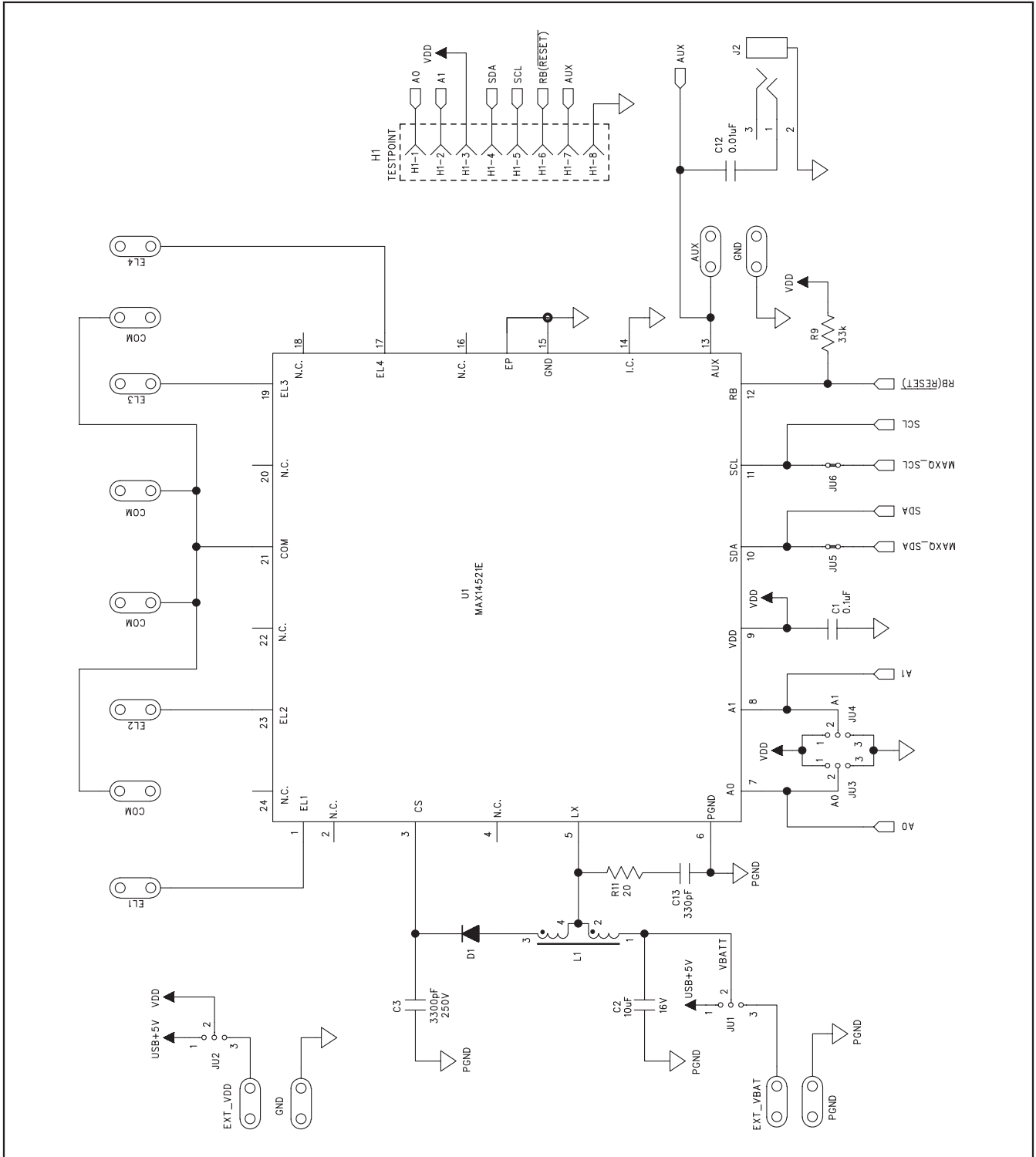

Figure 2a. MAX14521E EV Kit Schematic (Sheet 1 of 2)

MAX14521E Evaluation Kit

Evaluates: MAX14521E

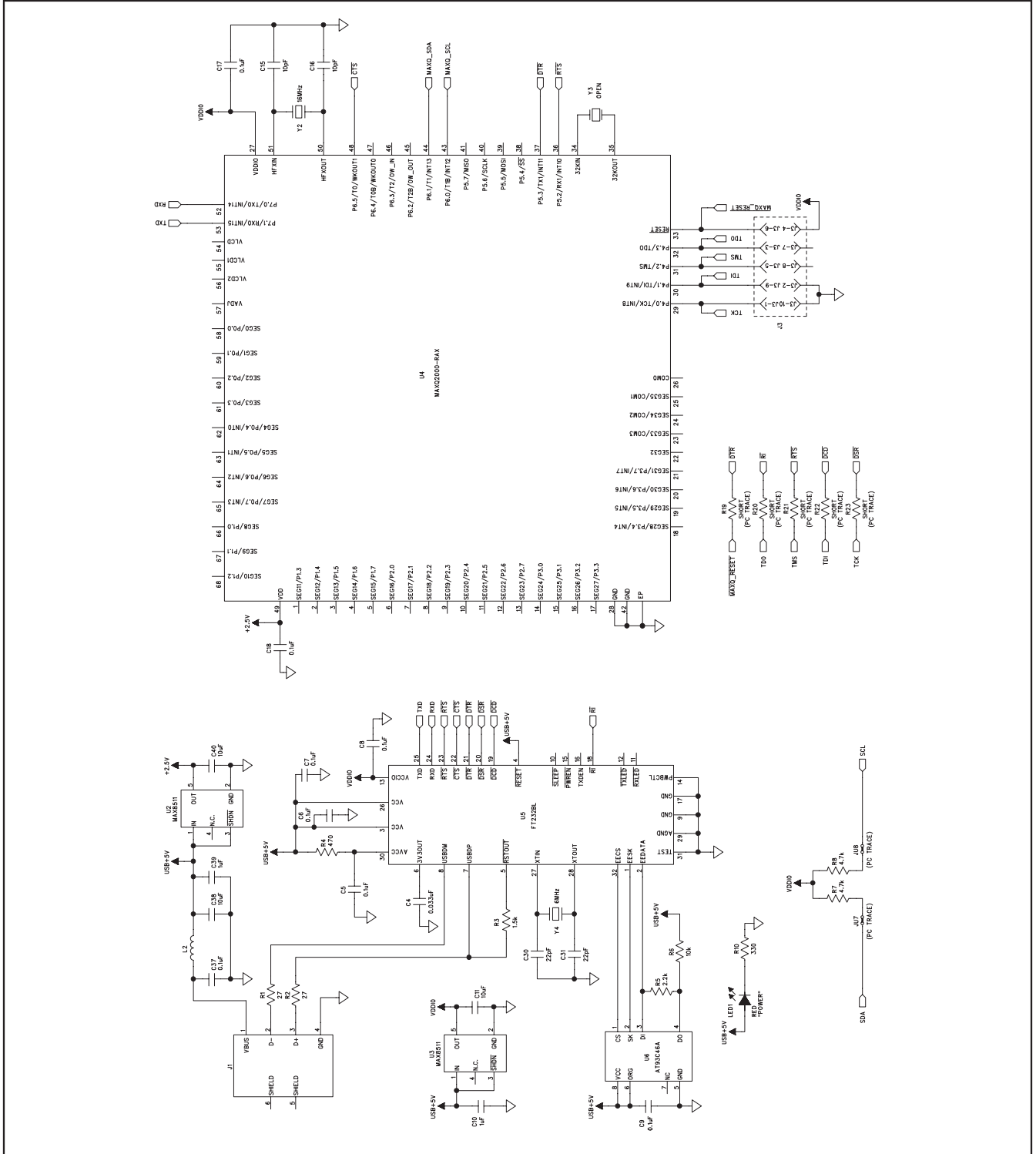

Figure 2b. MAX14521E EV Kit Schematic (Sheet 2 of 2)

MAX14521E Evaluation Kit

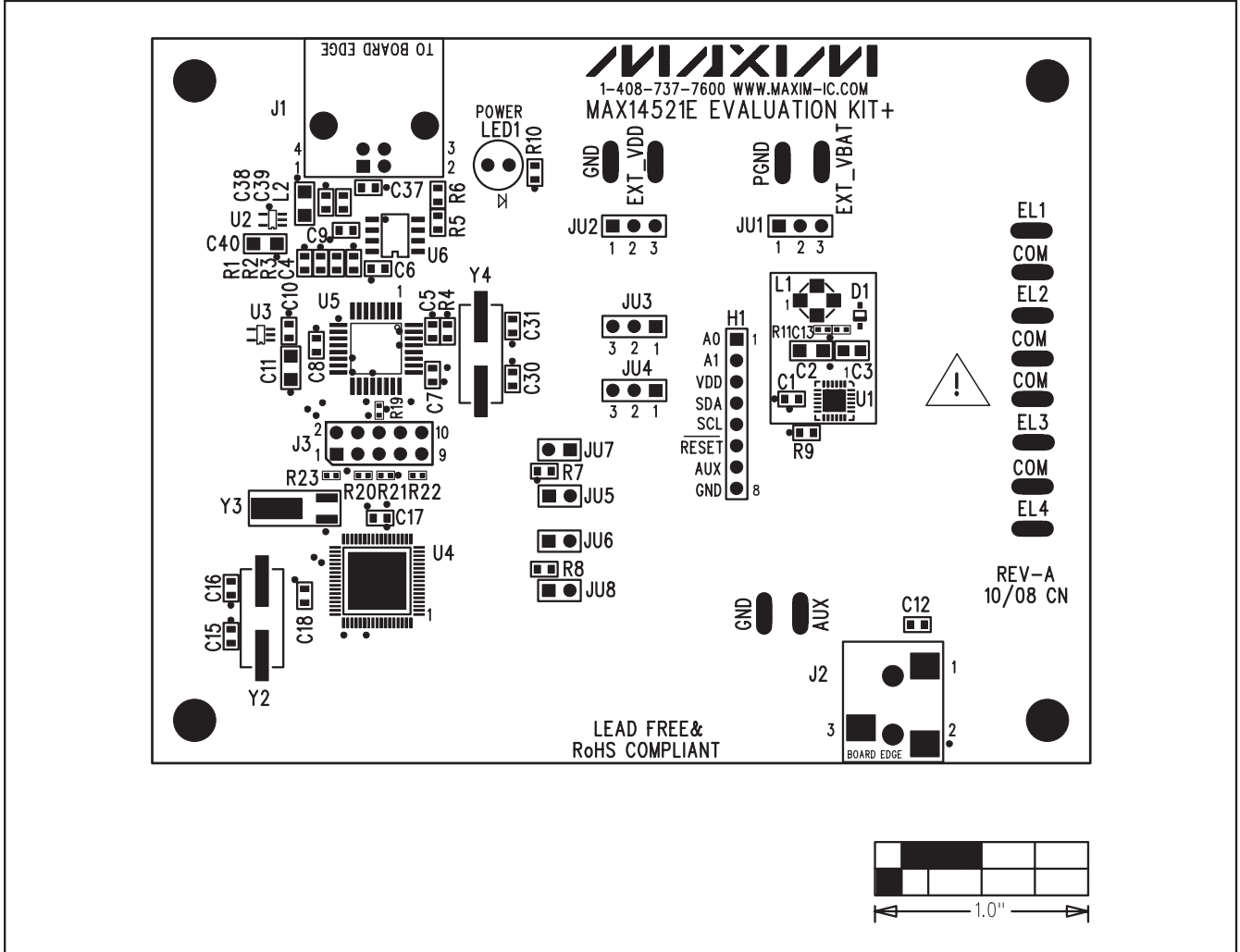

Figure 3. MAX14521E EV Kit Component Placement Guide—Component Side

MAX14521E Evaluation Kit

Evaluates: MAX14521E

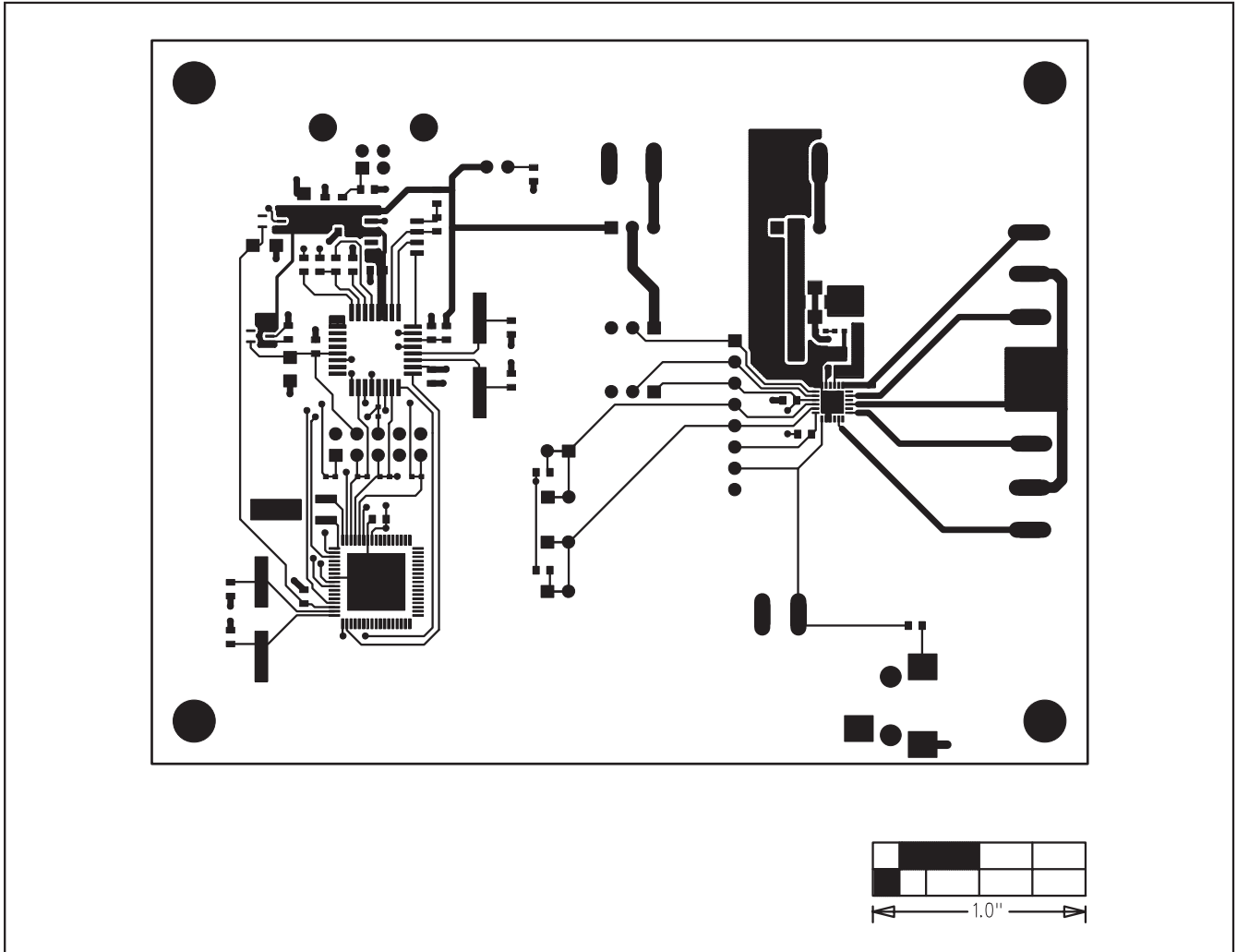

Figure 4. MAX14521E EV Kit PCB Layout—Component Side

MAX14521E Evaluation Kit

Evaluates: MAX14521E

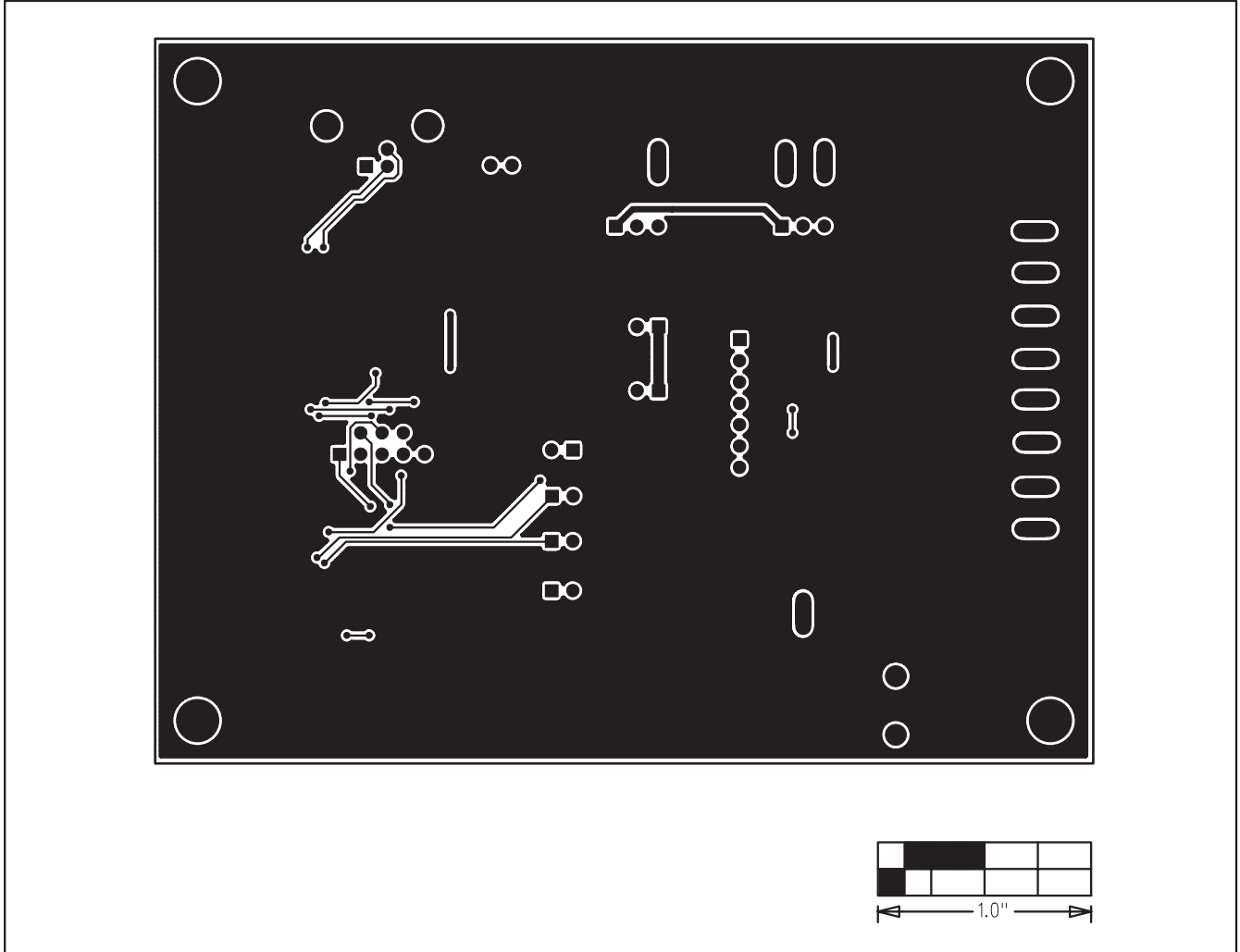

Figure 5. MAX14521E EV Kit PCB Layout—Solder Side

Maxim cannot assume responsibility for use of any circuitry other than circuitry entirely embodied in a Maxim product. No circuit patent licenses are implied. Maxim reserves the right to change the circuitry and specifications without notice at any time.

10 **Maxim Integrated Products, 120 San Gabriel Drive, Sunnyvale, CA 94086 408-737-7600**

© 2009 Maxim Integrated Products

Maxim is a registered trademark of Maxim Integrated Products, Inc.