

EVALUATION KIT
AVAILABLE

1.8V, 10-Bit, 250MSPS Analog-to-Digital Converter with LVDS Outputs for Wideband Applications

General Description

The MAX1124 is a monolithic 10-bit, 250MSPS analog-to-digital converter (ADC) optimized for outstanding dynamic performance at high IF frequencies up to 500MHz. The product operates with conversion rates of up to 250MSPS while consuming only 477mW.

At 250MSPS and an input frequency of 100MHz, the MAX1124 achieves a spurious-free dynamic range (SFDR) of 71dBc. Its excellent signal-to-noise ratio (SNR) of 57.1dB at 10MHz remains flat (within 1dB) for input tones up to 500MHz. This makes the MAX1124 ideal for wideband applications such as digital predistortion in cellular base-station transceiver systems.

The MAX1124 requires a single 1.8V supply. The analog input is designed for either differential or single-ended operation and can be AC- or DC-coupled. The ADC also features a selectable on-chip divide-by-2 clock circuit, which allows the user to apply clock frequencies as high as 500MHz. This helps to reduce the phase noise of the input clock source. A differential LVDS sampling clock is recommended for best performance. The converter's digital outputs are LVDS compatible, and the data format can be selected to be either two's complement or offset binary.

The MAX1124 is available in a 68-pin QFN with exposed pad (EP) and is specified over the industrial (-40°C to +85°C) temperature range.

For pin-compatible, lower speed versions of the MAX1124, refer to the MAX1122 (170MSPS) and the MAX1123 (210MSPS) data sheets. For a pin-compatible 8-bit version of the MAX1124, refer to the MAX1121 data sheet.

Applications

Wireless and Wired Broadband Communication
Cable-Head End Systems
Digital Predistortion Receivers
Communications Test Equipment
Radar and Satellite Subsystems Antenna Array Processing

Features

- ◆ 250MSPS Conversion Rate
- ◆ SNR = 56.8dB/55.5dB at $f_{IN} = 100\text{MHz}/500\text{MHz}$
- ◆ SFDR = 71dBc/63.8dBc at $f_{IN} = 100\text{MHz}/500\text{MHz}$
- ◆ NPR = 54.8dB at $f_{NOTCH} = 28.8\text{MHz}$
- ◆ Single 1.8V Supply
- ◆ 477mW Power Dissipation at 250MSPS
- ◆ On-Chip Track-and-Hold and Internal Reference
- ◆ On-Chip Selectable Divide-by-2 Clock Input
- ◆ LVDS Digital Outputs with Data Clock Output
- ◆ Evaluation Kit Available (Order MAX1124EVKIT)

Ordering Information

PART	TEMP RANGE	PIN-PACKAGE
MAX1124EGK	-40°C to +85°C	68 QFN-EP*

*EP = Exposed pad.

Pin Configuration

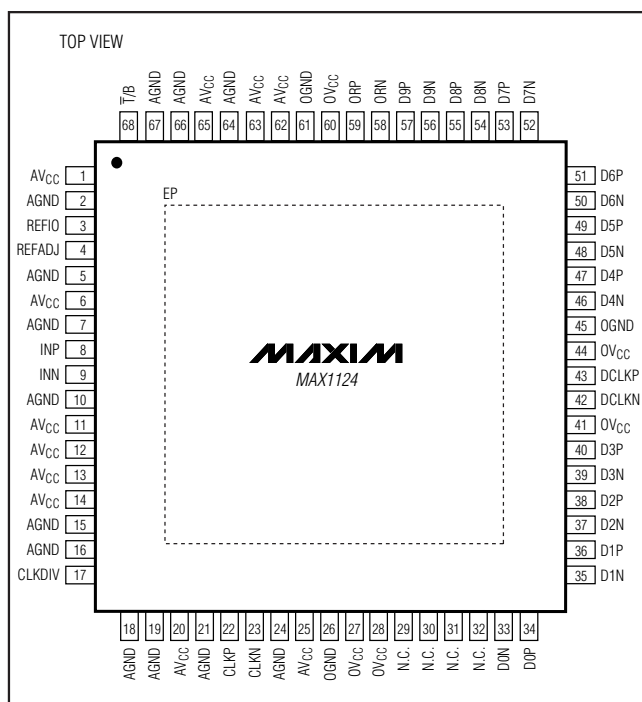

MAX1124

1.8V, 10-Bit, 250Mps Analog-to-Digital Converter with LVDS Outputs for Wideband Applications

ABSOLUTE MAXIMUM RATINGS

AV _{CC} to AGND	-0.3V to +2.1V
OV _{CC} to OGND	-0.3V to +2.1V
AV _{CC} to OV _{CC}	-0.3V to +2.1V
AGND to OGND	-0.3V to +0.3V
Analog Inputs to AGND	-0.3V to (AV _{CC} + 0.3V)
Digital Inputs to AGND	-0.3V to (AV _{CC} + 0.3V)
REF, REFADJ to AGND	-0.3V to (AV _{CC} + 0.3V)
Digital Outputs to OGND	-0.3V to (OV _{CC} + 0.3V)
ESD on All Pins (Human Body Model)	±2000V

Continuous Power Dissipation (T_A = +70°C)

68-Pin QFN (derate 41.7mW/°C above +70°C)	3333mW
Operating Temperature Range	-40°C to +85°C
Junction Temperature	+150°C
Storage Temperature Range	-60°C to +150°C
Lead Temperature (soldering, 10s)	+300°C
Maximum Current into Any Pin	50mA

Stresses beyond those listed under "Absolute Maximum Ratings" may cause permanent damage to the device. These are stress ratings only, and functional operation of the device at these or any other conditions beyond those indicated in the operational sections of the specifications is not implied. Exposure to absolute maximum rating conditions for extended periods may affect device reliability.

ELECTRICAL CHARACTERISTICS

(AV_{CC} = OV_{CC} = 1.8V, V_{AGND} = V_{OGND} = 0, f_{SAMPLE} = 250MHz, differential sine-wave clock input drive, 0.1µF capacitor on REFIO, internal reference, digital output pins differential R_L = 100Ω ±1%, C_L = 5pF, T_A = T_{MIN} to T_{MAX}, unless otherwise noted. ≥ +25°C guaranteed by production test, < +25°C guaranteed by design and characterization. Typical values are at T_A = +25°C.)

PARAMETER	SYMBOL	CONDITIONS	MIN	TYP	MAX	UNITS
DC ACCURACY						
Resolution			10			Bits
Integral Nonlinearity	INL	(Note 1)	-2.4	±0.8	+2.4	LSB
Differential Nonlinearity	DNL	No missing codes (Note 1)	-1.0	±0.5	+1.5	LSB
Transfer Curve Offset	V _{OS}	(Note 1)	T _A ≥ +25°C		+25	LSB
			(Note 2)	-37	+37	
Offset Temperature Drift				±20		µV/°C
ANALOG INPUTS (INP, INN)						
Full-Scale Input Voltage Range	V _{FS}	(Note 1)	1100	1250	1375	mV _{P-P}
Full-Scale Range Temperature Drift				130		ppm/°C
Common-Mode Input Range	V _{CM}			1.38 ±0.18		V
Input Capacitance	C _{IN}			3		pF
Differential Input Resistance	R _{IN}		3.00	4.3	6.25	kΩ
Full-Power Analog Bandwidth	FPBW	Figure 8		600		MHz
REFERENCE (REFIO, REFADJ)						
Reference Output Voltage	V _{REFIO}		1.18	1.24	1.30	V
Reference Temperature Drift				90		ppm/°C
REFADJ Input High Voltage	V _{REFADJ}	Used to disable the internal reference	AV _{CC} - 0.3			V
SAMPLING CHARACTERISTICS						
Maximum Sampling Rate	f _{SAMPLE}		250			MHz
Minimum Sampling Rate	f _{SAMPLE}			20		MHz

1.8V, 10-Bit, 250Mps Analog-to-Digital Converter with LVDS Outputs for Wideband Applications

ELECTRICAL CHARACTERISTICS (continued)

($V_{CC} = OV_{CC} = 1.8V$, $V_{AGND} = V_{OGND} = 0$, $f_{SAMPLE} = 250MHz$, differential sine-wave clock input drive, $0.1\mu F$ capacitor on REFIO, internal reference, digital output pins differential $R_L = 100\Omega \pm 1\%$, $C_L = 5pF$, $T_A = T_{MIN}$ to T_{MAX} , unless otherwise noted. $\geq +25^\circ C$ guaranteed by production test, $< +25^\circ C$ guaranteed by design and characterization. Typical values are at $T_A = +25^\circ C$.)

PARAMETER	SYMBOL	CONDITIONS	MIN	TYP	MAX	UNITS
Clock Duty Cycle		Set by clock management circuit		40 to 60		%
Aperture Delay	t_{AD}			350		ps
Aperture Jitter	t_{AJ}			0.2		psRMS
CLOCK INPUTS (CLKP, CLKN)						
Differential Clock Input Amplitude		(Note 2)	200	500		mVp-p
Clock Input Common-Mode Voltage Range				1.15 ± 0.25		V
Clock Differential Input Resistance	R_{CLK}			$11 \pm 25\%$		k Ω
Clock Differential Input Capacitance	C_{CLK}			5		pF
DYNAMIC CHARACTERISTICS (at -0.5dBFS)						
Signal-to-Noise Ratio	SNR	$f_{IN} = 10MHz$, $T_A \geq +25^\circ C$	54.3	57.1		dB
		$f_{IN} = 100MHz$, $T_A \geq +25^\circ C$	54	56.8		
		$f_{IN} = 180MHz$		56.3		
		$f_{IN} = 500MHz$		55.5		
Signal-to-Noise and Distortion	SINAD	$f_{IN} = 10MHz$, $T_A \geq +25^\circ C$	54	57		dB
		$f_{IN} = 100MHz$, $T_A \geq +25^\circ C$	53.5	56.5		
		$f_{IN} = 180MHz$		56		
		$f_{IN} = 500MHz$		55		
Spurious-Free Dynamic Range	SFDR	$f_{IN} = 10MHz$, $T_A \geq +25^\circ C$	62.6	75		dBc
		$f_{IN} = 100MHz$, $T_A \geq +25^\circ C$	62	71		
		$f_{IN} = 180MHz$		68.3		
		$f_{IN} = 500MHz$		63.8		
Worst Harmonics (HD2 or HD3)		$f_{IN} = 10MHz$		-75		dBc
		$f_{IN} = 100MHz$		-71		
		$f_{IN} = 180MHz$		-68.3		
		$f_{IN} = 500MHz$		-63.8		
Two-Tone Intermodulation Distortion	IMD ₁₀₀	$f_{IN1} = 99MHz$ at -7dBFS, $f_{IN2} = 101MHz$ at -7dBFS		-65		dBc
	IMD ₅₀₀	$f_{IN1} = 498.5MHz$ at -7dBFS, $f_{IN2} = 502.5MHz$ at -7dBFS		-56		
LVDS DIGITAL OUTPUTS (D0P/N–D9P/N, ORP/N)						
Differential Output Voltage	I_{VODI}		250		450	mV

1.8V, 10-Bit, 250Mps Analog-to-Digital Converter with LVDS Outputs for Wideband Applications

ELECTRICAL CHARACTERISTICS (continued)

($V_{CC} = OV_{CC} = 1.8V$, $V_{AGND} = V_{OGND} = 0$, $f_{SAMPLE} = 250MHz$, differential sine-wave clock input drive, $0.1\mu F$ capacitor on REFIO, internal reference, digital output pins differential $R_L = 100\Omega \pm 1\%$, $C_L = 5pF$, $T_A = T_{MIN}$ to T_{MAX} , unless otherwise noted. $\geq +25^\circ C$ guaranteed by production test, $< +25^\circ C$ guaranteed by design and characterization. Typical values are at $T_A = +25^\circ C$.)

PARAMETER	SYMBOL	CONDITIONS	MIN	TYP	MAX	UNITS
Output Offset Voltage	OV_{OS}		1.125		1.310	V
LVCOS DIGITAL INPUTS (CLKDIV, \bar{T}/B)						
Digital Input Voltage Low	V_{IL}				$0.2 \times AV_{CC}$	V
Digital Input Voltage High	V_{IH}		$0.8 \times AV_{CC}$			V
TIMING CHARACTERISTICS						
CLK to Data Propagation Delay	t_{PDL}	Figure 4		1.5		ns
CLK to DCLK Propagation Delay	t_{CPDL}	Figure 4		2.85		ns
Data Valid to DCLK Rising Edge	$t_{CPDL} - t_{PDL}$	Figure 4 (Note 2)	0.92	1.35	1.86	ns
LVDS Output Rise-Time	t_{RISE}	20% to 80%, $C_L = 5pF$		460		ps
LVDS Output Fall-Time	t_{FALL}	20% to 80%, $C_L = 5pF$		460		ps
Output Data Pipeline Delay	$t_{LATENCY}$			8		Clock cycles
POWER REQUIREMENTS						
Analog Supply Voltage Range	AV_{CC}		1.7	1.8	1.9	V
Digital Supply Voltage Range	OV_{CC}		1.7	1.8	1.9	V
Analog Supply Current	I_{AVCC}	$f_{IN} = 100MHz$		220	290	mA
Digital Supply Current	I_{OVCC}	$f_{IN} = 100MHz$		45	75	mA
Total Power Dissipation	P_{DISS}	$f_{IN} = 100MHz$		477	657	mW
Power-Supply Rejection Ratio (Note 3)	PSRR	Offset		1.6		mV/V
		Gain		1.9		%FS/V

Note 1: Static linearity and offset parameters are computed from a best-fit straight line through the code transition points. The full-scale range is defined as $1023 \times$ slope of the line.

Note 2: Parameter guaranteed by design and characterization; $T_A = T_{MIN}$ to T_{MAX} .

Note 3: PSRR is measured with both analog and digital supplies connected to the same potential.

1.8V, 10-Bit, 250Mps Analog-to-Digital Converter with LVDS Outputs for Wideband Applications

Typical Operating Characteristics

($V_{CC} = OV_{CC} = 1.8V$, $V_{AGND} = V_{OGND} = 0$, $f_{SAMPLE} = 250.0057MHz$, $-0.5dBFS$; see TOCs for detailed information on test conditions, differential input drive, differential sine-wave clock input drive, $0.1\mu F$ capacitor on REFIO, internal reference, digital output pins differential $R_L = 100\Omega$, $T_A = +25^\circ C$.)

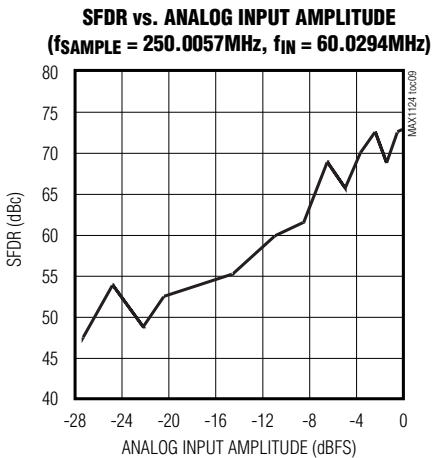
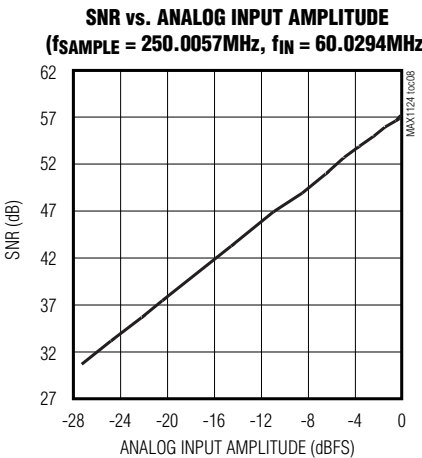
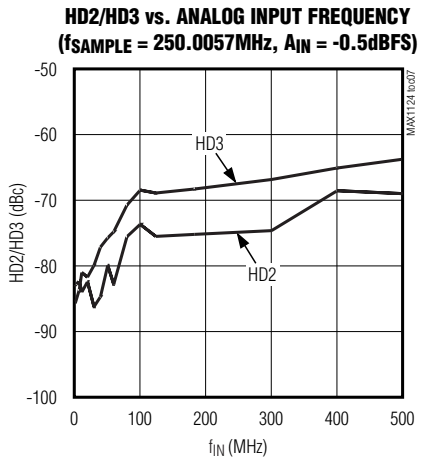
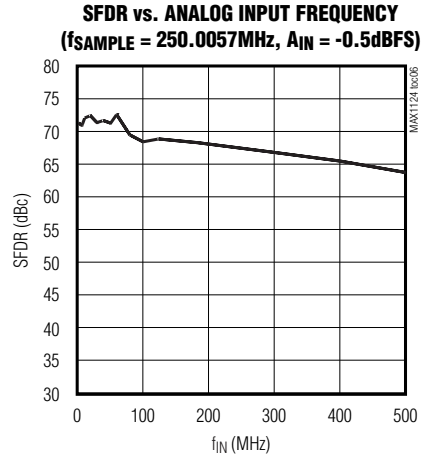
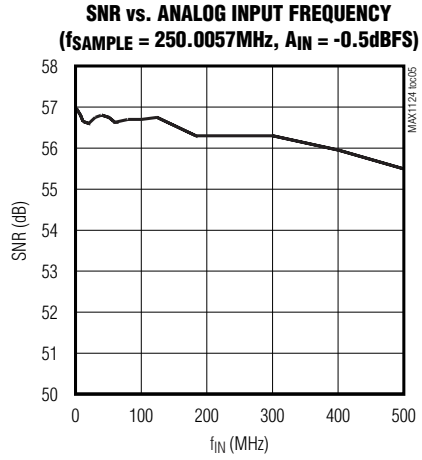
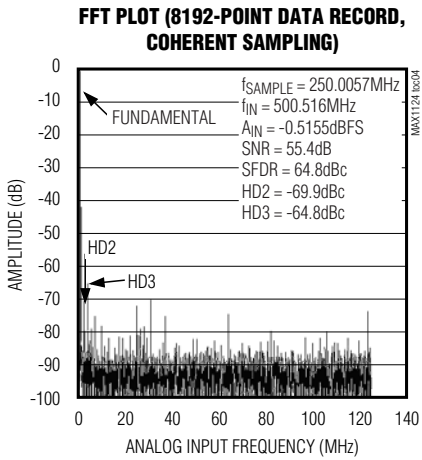
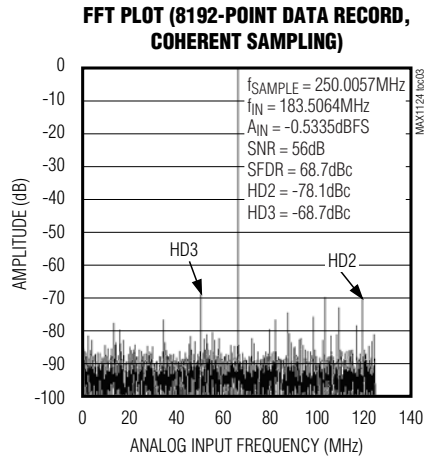
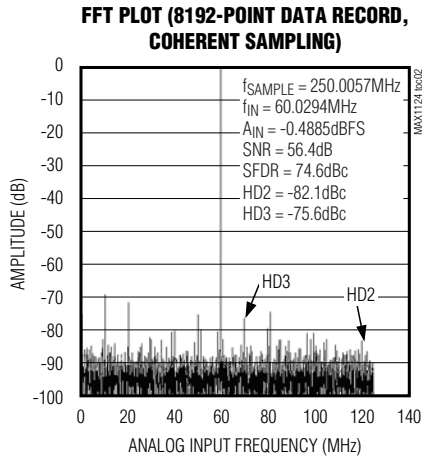
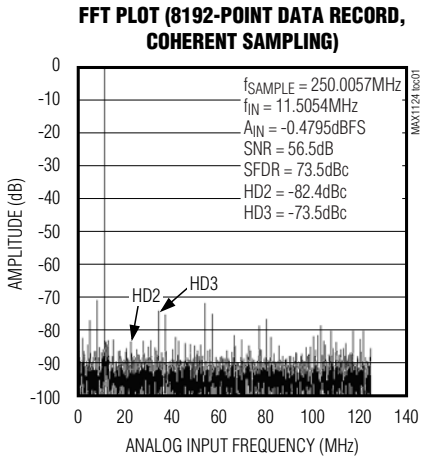

1.8V, 10-Bit, 250Mps Analog-to-Digital Converter with LVDS Outputs for Wideband Applications

Typical Operating Characteristics (continued)

($V_{CC} = OV_{CC} = 1.8V$, $V_{AGND} = V_{OGND} = 0$, $f_{SAMPLE} = 250.0057MHz$, $-0.5dBFS$; see TOCs for detailed information on test conditions, differential input drive, differential sine-wave clock input drive, $0.1\mu F$ capacitor on REFIO, internal reference, digital output pins differential $R_L = 100\Omega$, $T_A = +25^\circ C$.)

HD2/HD3 vs. ANALOG INPUT AMPLITUDE
($f_{SAMPLE} = 250.0057MHz$, $f_{IN} = 60.0294MHz$)

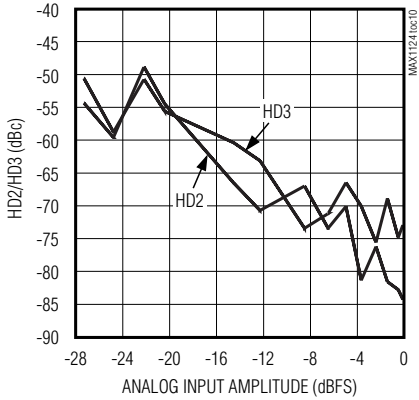

SNR vs. f_{SAMPLE}
($f_{IN} = 60.0294MHz$, $A_{IN} = -0.5dBFS$)

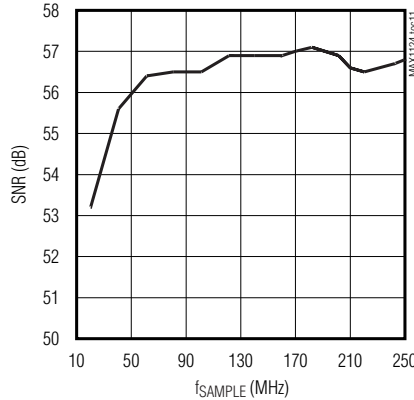

SFDR vs. f_{SAMPLE}
($f_{IN} = 60.0294MHz$, $A_{IN} = -0.5dBFS$)

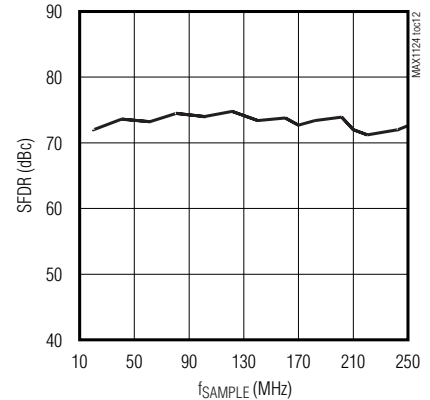

HD2/HD3 vs. f_{SAMPLE}
($f_{IN} = 60.03294MHz$, $A_{IN} = -0.5dBFS$)

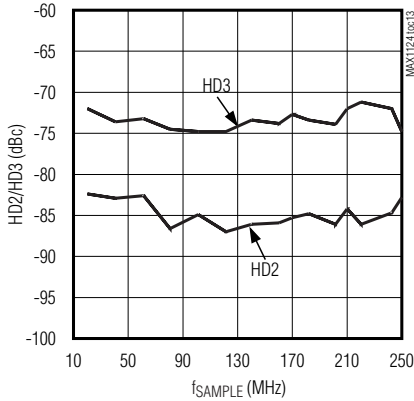

TWO-TONE IMD PLOT (8192-POINT DATA RECORD, COHERENT SAMPLING)

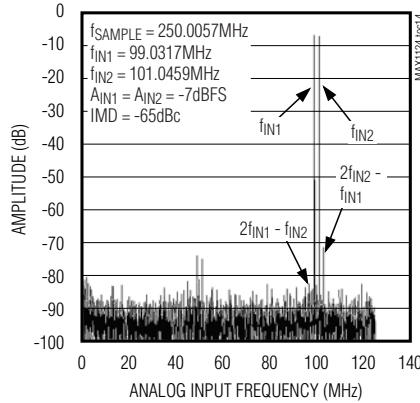

INTEGRAL NONLINEARITY vs. DIGITAL OUTPUT CODE

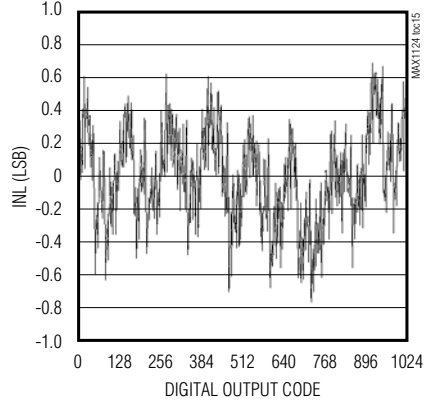

DIFFERENTIAL NONLINEARITY vs. DIGITAL OUTPUT CODE

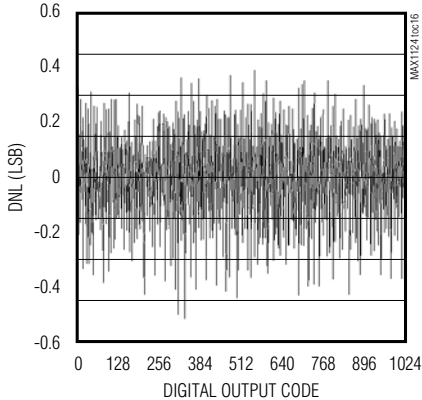

GAIN BANDWIDTH PLOT
($f_{SAMPLE} = 250.0057MHz$, $A_{IN} = -0.5dBFS$)

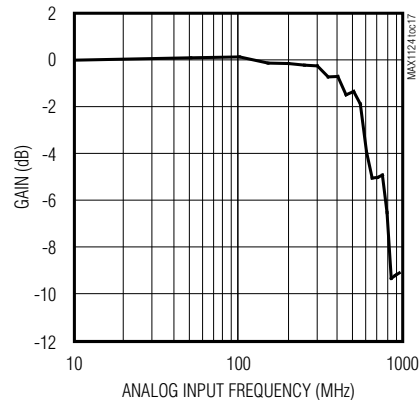

SNR vs. TEMPERATURE ($f_{IN} = 65.0344MHz$, $f_{SAMPLE} = 250.0057MHz$, $A_{IN} = -0.5dBFS$)

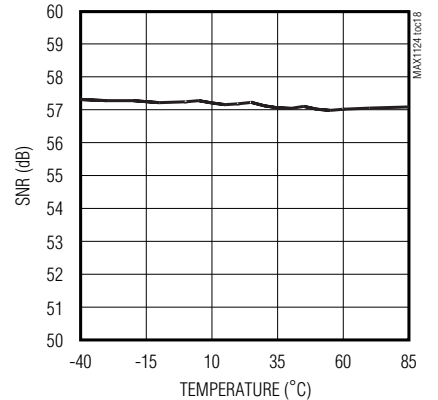

1.8V, 10-Bit, 250Mps Analog-to-Digital Converter with LVDS Outputs for Wideband Applications

Typical Operating Characteristics (continued)

($V_{CC} = OV_{CC} = 1.8V$, $V_{AGND} = V_{OGND} = 0$, $f_{SAMPLE} = 250.0057MHz$, $-0.5dBFS$; see TOCs for detailed information on test conditions, differential input drive, differential sine-wave clock input drive, $0.1\mu F$ capacitor on REFIO, internal reference, digital output pins differential $R_L = 100\Omega$, $T_A = +25^\circ C$.)

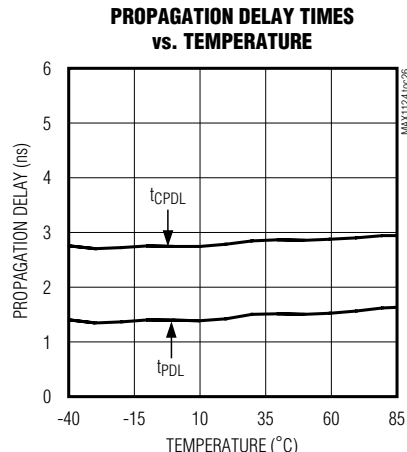
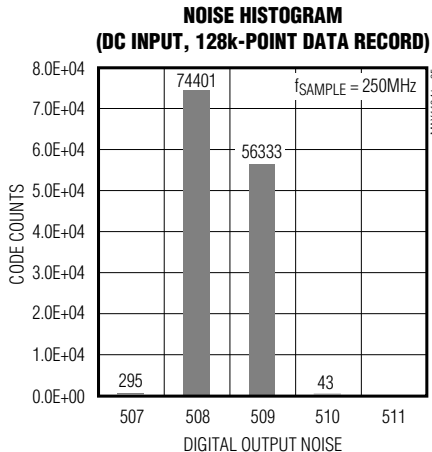
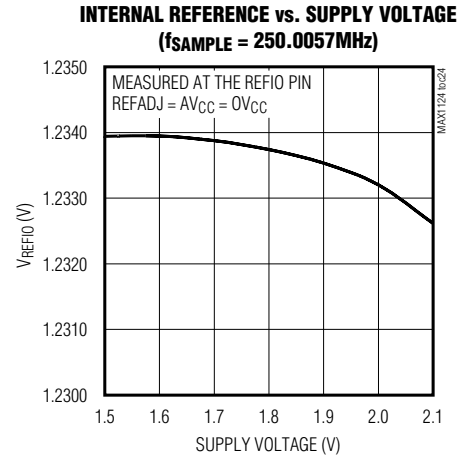
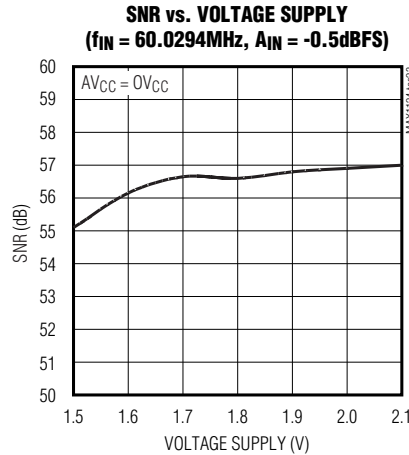
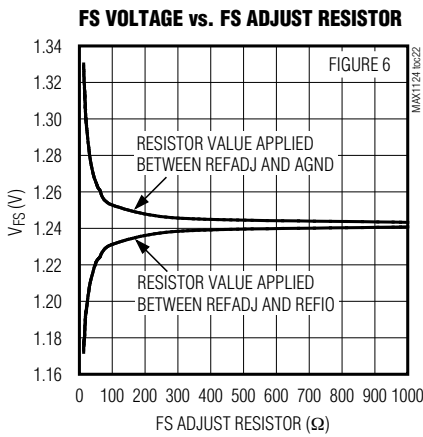
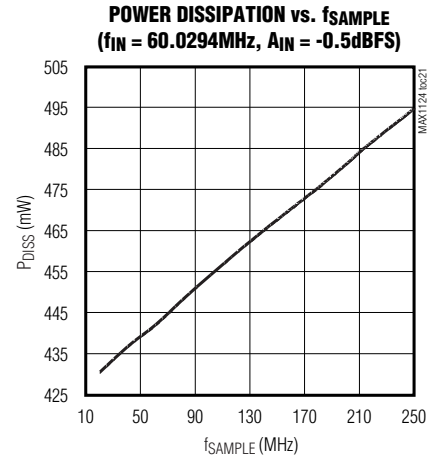
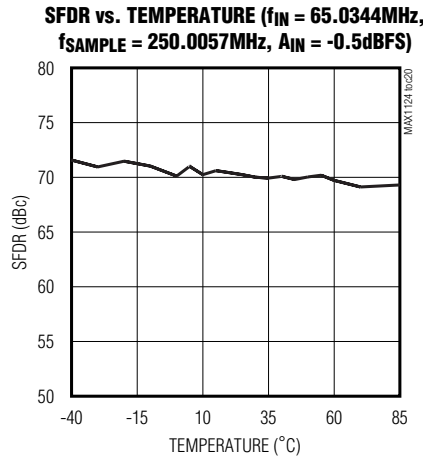
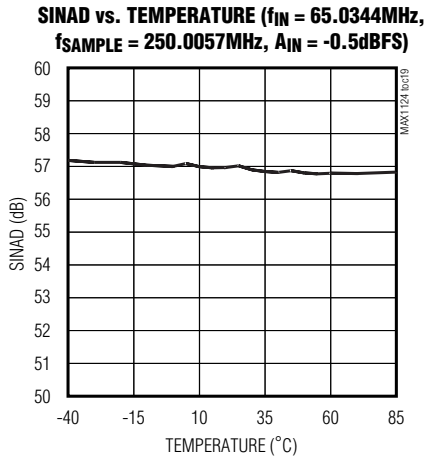

1.8V, 10-Bit, 250Mps Analog-to-Digital Converter with LVDS Outputs for Wideband Applications

Typical Operating Characteristics (continued)

($V_{CC} = OV_{CC} = 1.8V$, $V_{AGND} = V_{OGND} = 0$, $f_{SAMPLE} = 250.0057MHz$, $-0.5dBFS$; see TOCs for detailed information on test conditions, differential input drive, differential sine-wave clock input drive, $0.1\mu F$ capacitor on REFIO, internal reference, digital output pins differential $R_L = 100\Omega$, $T_A = +25^\circ C$.)

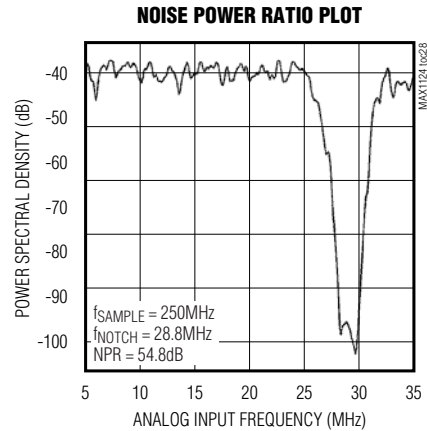
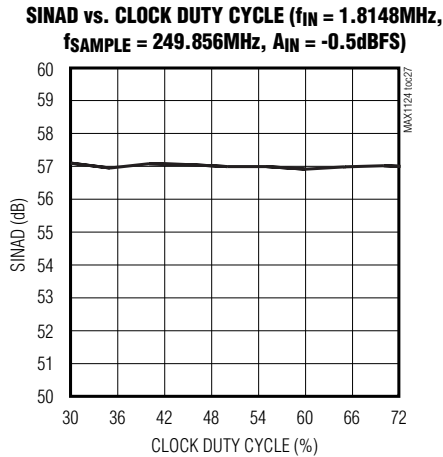

Pin Description

PIN	NAME	FUNCTION
1, 6, 11–14, 20, 25, 62, 63, 65	AV _{CC}	Analog Supply Voltage. Bypass each pin with a $0.1\mu F$ capacitor for best decoupling results.
2, 5, 7, 10, 15, 16, 18, 19, 21, 24, 64, 66, 67, EP	AGND	Analog Converter Ground. Connect the converter's exposed pad (EP) to AGND.
3	REFIO	Reference Input/Output. With REFADJ pulled high through a $1k\Omega$ resistor, this I/O port allows an external reference source to be connected to the MAX1124. With REFADJ pulled low through the same $1k\Omega$ resistor, the internal $1.23V$ bandgap reference is active.
4	REFADJ	Reference-Adjust Input. REFADJ allows for full-scale range adjustments by placing a resistor or trim potentiometer between REFADJ and AGND (decreases FS range) or REFADJ and REFIO (increases FS range). If REFADJ is connected to AV _{CC} through a $1k\Omega$ resistor, the internal reference can be overdriven with an external source connected to REFIO. If REFADJ is connected to AGND through a $1k\Omega$ resistor, the internal reference is used to determine the full-scale range of the data converter.
8	INP	Positive Analog Input Terminal
9	INN	Negative Analog Input Terminal
17	CLKDIV	Clock Divider Input. This LVCMOS-compatible input controls which speed the converter's digital outputs are updated. CLKDIV has an internal pulldown resistor. CLKDIV = 0: ADC updates digital outputs at one-half the input clock rate. CLKDIV = 1: ADC updates digital outputs at the input clock rate.
22	CLKP	True Clock Input. This input requires an LVDS-compatible input level to maintain the converter's excellent performance.
23	CLKN	Complementary Clock Input. This input requires an LVDS-compatible input level to maintain the converter's excellent performance.

1.8V, 10-Bit, 250Mps Analog-to-Digital Converter with LVDS Outputs for Wideband Applications

Pin Description (continued)

MAX1124

PIN	NAME	FUNCTION
26, 45, 61	OGND	Digital Converter Ground. Ground connection for digital circuitry and output drivers.
27, 28, 41, 44, 60	OVCC	Digital Supply Voltage. Bypass with a 0.1μF capacitor for best decoupling results.
29–32	N.C.	No Connection. Do not connect to these pins.
33	D0N	Complementary Output Bit 0 (LSB)
34	D0P	True Output Bit 0 (LSB)
35	D1N	Complementary Output Bit 1
36	D1P	True Output Bit 1
37	D2N	Complementary Output Bit 2
38	D2P	True Output Bit 2
39	D3N	Complementary Output Bit 3
40	D3P	True Output Bit 3
42	DCLKN	Complementary Clock Output. This output provides an LVDS-compatible output level and can be used to synchronize external devices to the converter clock. There is a 2.1ns delay between CLKN and DCLKN.
43	DCLKP	True Clock Output. This output provides an LVDS-compatible output level and can be used to synchronize external devices to the converter clock. There is a 2.1ns delay between CLKP and DCLKP.
46	D4N	Complementary Output Bit 4
47	D4P	True Output Bit 4
48	D5N	Complementary Output Bit 5
49	D5P	True Output Bit 5
50	D6N	Complementary Output Bit 6
51	D6P	True Output Bit 6
52	D7N	Complementary Output Bit 7
53	D7P	True Output Bit 7
54	D8N	Complementary Output Bit 8
55	D8P	True Output Bit 8
56	D9N	Complementary Output Bit 9 (MSB)
57	D9P	True Output Bit 9 (MSB)
58	ORN	Complementary Output for Out-of-Range Control Bit. If an out-of-range condition is detected, bit ORN flags this condition by transitioning low.
59	ORP	True Output for Out-of-Range Control Bit. If an out-of-range condition is detected, bit ORP flags this condition by transitioning high.
68	\bar{T}/B	Two's Complement or Binary Output Format Selection. This LVCMOS-compatible input controls the digital output format of the MAX1124. \bar{T}/B has an internal pull-down resistor. $\bar{T}/B = 0$: Two's complement output format $\bar{T}/B = 1$: Binary output format

1.8V, 10-Bit, 250Mps Analog-to-Digital Converter with LVDS Outputs for Wideband Applications

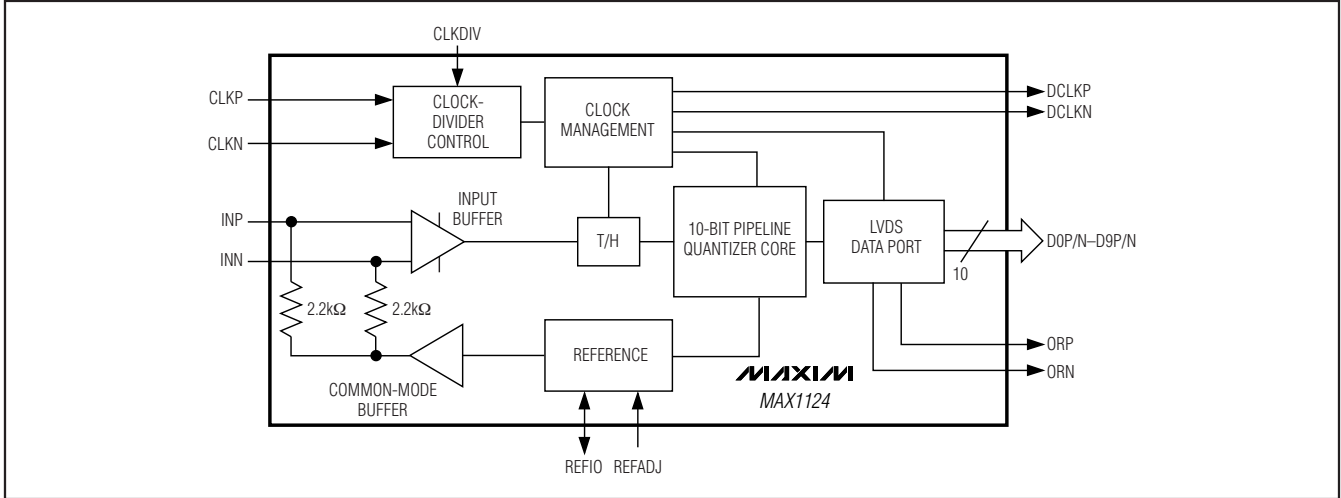

Figure 1. MAX1124 Block Diagram

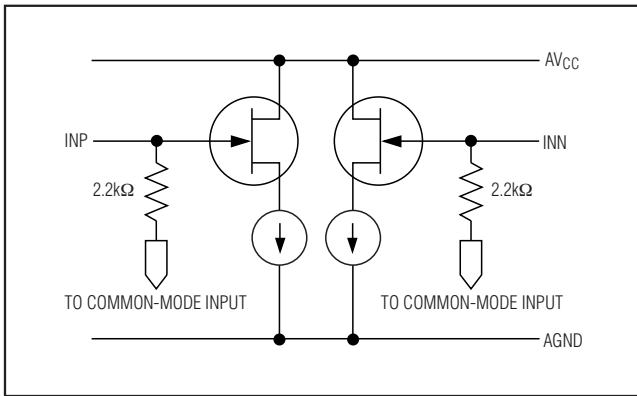

Figure 2. Simplified Analog Input Architecture

Detailed Description—Theory of Operation

The MAX1124 uses a fully differential, pipelined architecture that allows for high-speed conversion, optimized accuracy and linearity, while minimizing power consumption and die size.

Both positive (INP) and negative/complementary analog input terminals (INN) are centered around a common-mode voltage of 1.4V, and accept a differential analog input voltage swing of $\pm 0.3125V$ each, resulting in a typical differential full-scale signal swing of $1.25V_{P-P}$.

INP and INN are buffered prior to entering each track-and-hold (T/H) stage and are sampled when the differential sampling clock signal transitions high. A 2-bit ADC following the first T/H stage then digitizes the signal, and controls a 2-bit digital-to-analog converter (DAC).

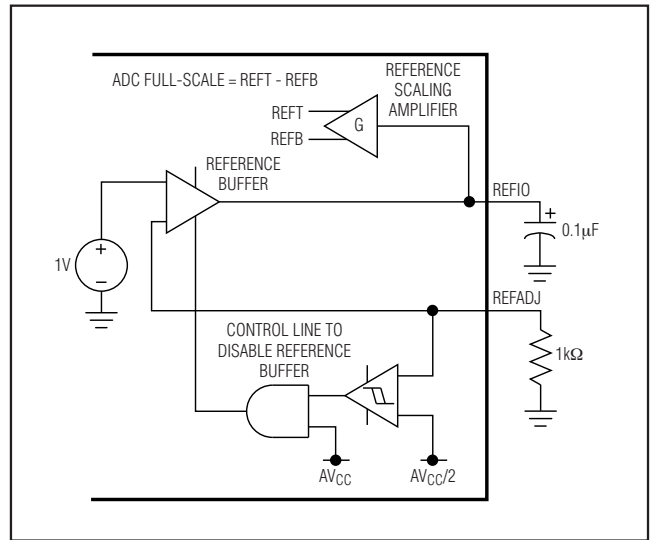

Figure 3. Simplified Reference Architecture

Digitized and reference signals are then subtracted, resulting in a fractional residue signal that is amplified before it is passed on to the next stage through another T/H amplifier. This process is repeated until the applied input signal has successfully passed through all stages of the 10-bit quantizer. Finally, the digital outputs of all stages are combined and corrected for in the digital correction logic to generate the final output code. The result is a 10-bit parallel digital output word in user-selectable two's complement or binary output formats with LVDS-compatible output levels. See Figure 1 for a more detailed view of the MAX1124 architecture.

1.8V, 10-Bit, 250MSPS Analog-to-Digital Converter with LVDS Outputs for Wideband Applications

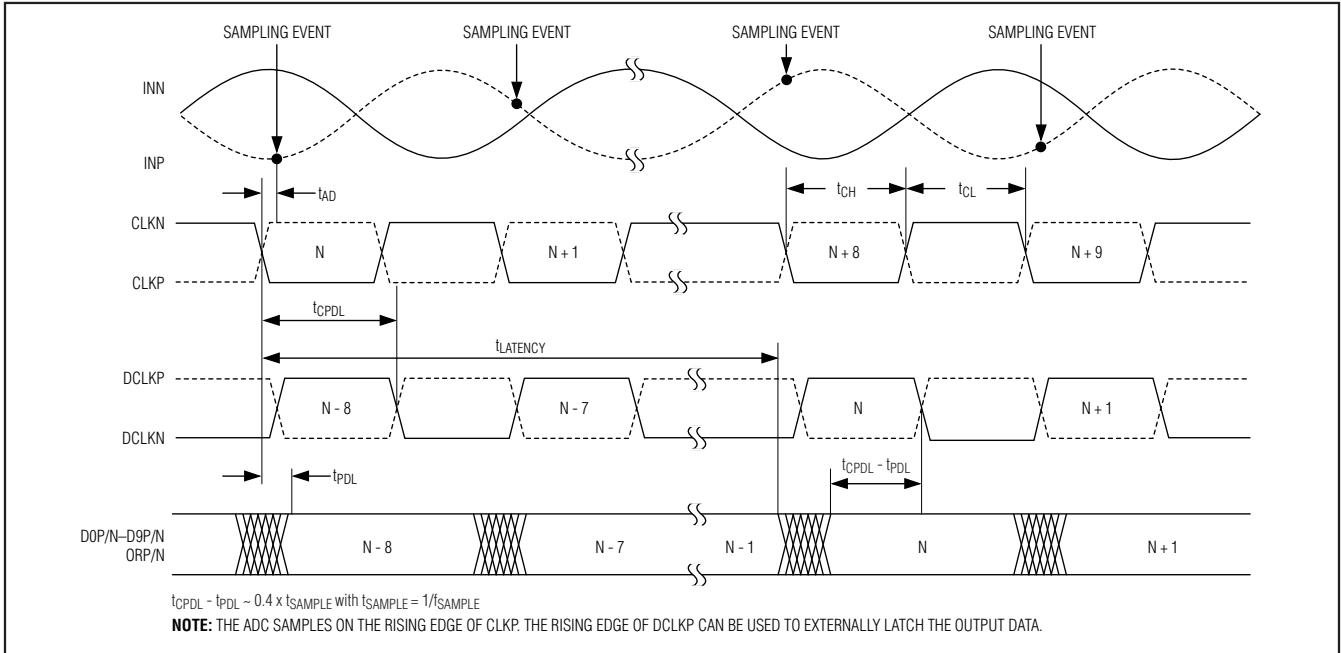

Figure 4. System and Output Timing Diagram

Analog Inputs (INP, INN)

INP and INN are the fully differential inputs of the MAX1124. Differential inputs usually feature good rejection of even-order harmonics, which allows for enhanced AC performance as the signals are progressing through the analog stages. The MAX1124 analog inputs are self-biased at a common-mode voltage of 1.4V and allow a differential input voltage swing of 1.25V_{P-P}. Both inputs are self-biased through 2.2kΩ resistors, resulting in a typical differential input resistance of 4.4kΩ. It is recommended to drive the analog inputs of the MAX1124 in AC-coupled configuration to achieve best dynamic performance. See the *AC-Coupled Analog Inputs* section for a detailed discussion of this configuration.

On-Chip Reference Circuit

The MAX1124 features an internal 1.23V bandgap reference circuit (Figure 3), which, in combination with an internal reference-scaling amplifier, determines the full-scale range of the MAX1124. Bypass REFIO with a 0.1μF capacitor to AGND. To compensate for gain errors or increase the ADC's full-scale range, the voltage of this bandgap reference can be indirectly adjusted by adding an external resistor (e.g., 100kΩ trim potentiometer) between REFADJ and AGND or REFADJ and REFIO. See the *Applications Information* section for a detailed description of this process.

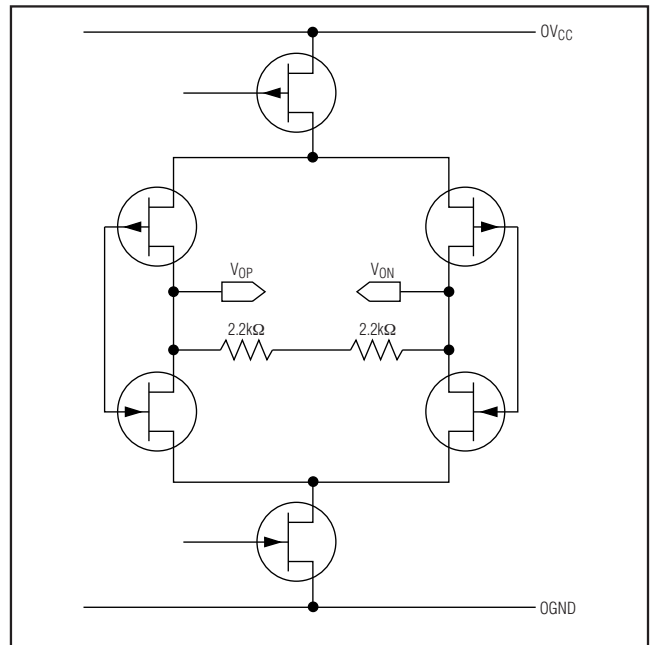

Figure 5. Simplified LVDS Output Architecture

Clock Inputs (CLKP, CLKN)

Designed for a differential LVDS clock input drive, it is recommended to drive the clock inputs of the MAX1124

1.8V, 10-Bit, 250Mps Analog-to-Digital Converter with LVDS Outputs for Wideband Applications

Table 1. MAX1124 Digital Output Coding

INP ANALOG VOLTAGE LEVEL	INN ANALOG VOLTAGE LEVEL	OUT-OF-RANGE ORP (ORN)	BINARY DIGITAL OUTPUT CODE (D9–D0)	TWO'S COMPLEMENT DIGITAL OUTPUT CODE (D9–D0)
$> V_{CM} + 0.3125V$	$< V_{CM} - 0.3125V$	1 (0)	11 1111 1111 (exceeds positive full scale, OR set)	01 1111 1111 (exceeds positive full scale, OR set)
$V_{CM} + 0.3125V$	$V_{CM} - 0.3125V$	0 (1)	11 1111 1111 (represents positive full scale)	01 1111 1111 (represents positive full scale)
V_{CM}	V_{CM}	0 (1)	10 0000 0000 or 01 1111 1111 (represents midscale)	00 0000 0000 or 11 1111 1111 (represents midscale)
$V_{CM} - 0.3125V$	$V_{CM} + 0.3125V$	0 (1)	00 0000 0000 (represents negative full scale)	10 0000 0000 (represents negative full scale)
$< V_{CM} - 0.3125V$	$> V_{CM} + 0.3125V$	1 (0)	00 0000 0000 (exceeds negative full scale, OR set)	10 0000 0000 (exceeds negative full scale, OR set)

with an LVDS-compatible clock to achieve the best dynamic performance. The clock signal source must be a high-quality, low phase noise to avoid any degradation in the noise performance of the ADC. The clock inputs (CLKP, CLKN) are internally biased to 1.2V, accept a differential signal swing of 0.2V_{P-P} to 1.0V_{P-P} and are usually driven in AC-coupled configuration. See the *Differential, AC-Coupled Clock Input* in the *Applications Information* section for more circuit details on how to drive CLKP and CLKN appropriately. Although not recommended, the clock inputs also accept a single-ended input signal.

The MAX1124 also features an internal clock management circuit (duty-cycle equalizer) that ensures that the clock signal applied to inputs CLKP and CLKN is processed to provide a 50% duty cycle clock signal, which desensitizes the performance of the converter to variations in the duty cycle of the input clock source. Note that the clock duty-cycle equalizer cannot be turned off externally and requires a minimum clock frequency of >20MHz to work appropriately and according to data sheet specifications.

Clock Outputs (DCLKP, DCLKN)

The MAX1124 features a differential clock output, which can be used to latch the digital output data with an external latch or receiver. Additionally, the clock output

can be used to synchronize external devices (e.g., FPGAs) to the ADC. DCLKP and DCLKN are differential outputs with LVDS-compatible voltage levels. There is a 2.1ns delay time between the rising (falling) edge of CLKP (CLKN) and the rising edge of DCLKP (DCLKN). See Figure 4 for timing details.

Divide-by-2 Clock Control (CLKDIV)

The MAX1124 offers a clock control line (CLKDIV), which supports the reduction of clock jitter in a system. Connect CLKDIV to OGND to enable the ADC's internal divide-by-2 clock divider. Data is now updated at one-half the ADC's input clock rate. CLKDIV has an internal pulldown resistor and can be left open for applications that only operate with update rates one-half of the converter's sampling rate. Connecting CLKDIV to OV_{CC} allows data to be updated at the speed of the ADC input clock.

System Timing Requirements

Figure 4 depicts the relationship between the clock input and output, analog input, sampling event, and data output. The MAX1124 samples on the rising (falling) edge of CLKP (CLKN). Output data is valid on the next rising (falling) edge of the DCLKP (DCLKN) clock, but has an internal latency of nine clock cycles.

1.8V, 10-Bit, 250Mps Analog-to-Digital Converter with LVDS Outputs for Wideband Applications

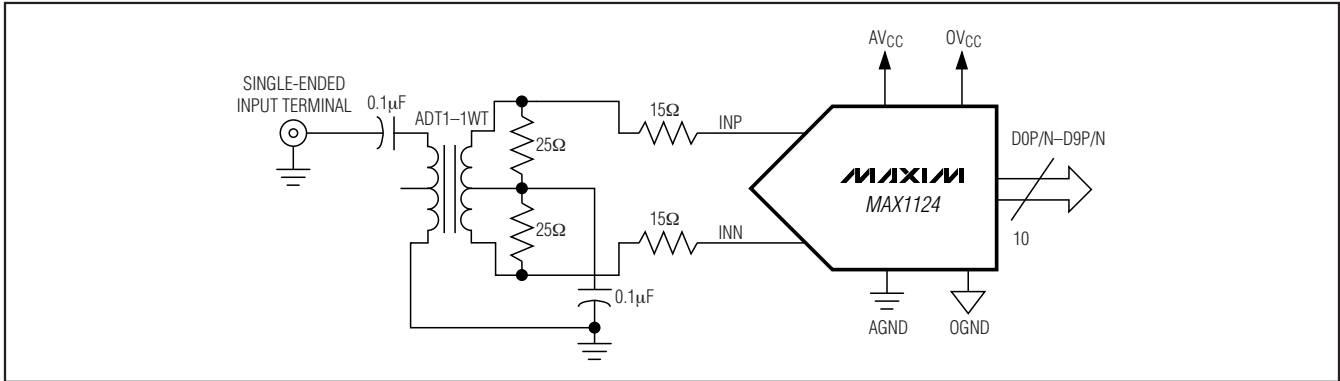

Figure 8. Transformer-Coupled Analog Input Configuration with Secondary-Side Termination

determined resistor value between REFADJ and REFIO increases the full-scale range of the data converter. Figure 6 shows the two possible configurations and their impact on the overall full-scale range adjustment of the MAX1124. Do not use resistor values of less than 13kΩ to avoid instability of the internal gain regulation loop for the bandgap reference.

Differential, AC-Coupled, PECL-Compatible Clock Input

The preferred method of clocking the MAX1124 is differentially with LVDS- or PECL-compatible input levels. To accomplish this, a 50Ω reverse-terminated clock signal source with low phase noise is AC-coupled into a fast differential receiver such as the MC100LVEL16 (Figure 7). The receiver produces the necessary PECL output levels to drive the clock inputs of the data converter.

Differential, AC-Coupled Analog Input

An RF transformer provides an excellent solution to convert a single-ended source signal to a fully differential signal, required by the MAX1124 for optimum dynamic performance. In general, the MAX1124 provides the best SFDR and THD with fully differential input signals and it is not recommended to drive the ADC inputs in single-ended configuration. In differential input mode, even-order harmonics are usually lower since INP and INN are balanced, and each of the ADC inputs only requires half the signal swing compared to a single-ended configuration.

Figure 8 depicts a secondary-side termination of the 1:1 transformer into two separate 25Ω loads. Terminating the transformer in this fashion reduces the potential effects of transformer parasitics. The source impedance combined with the shunt capacitance provided by a PCB and the ADC's parasitic capacitance reduce the combined bandwidth to approximately 550MHz.

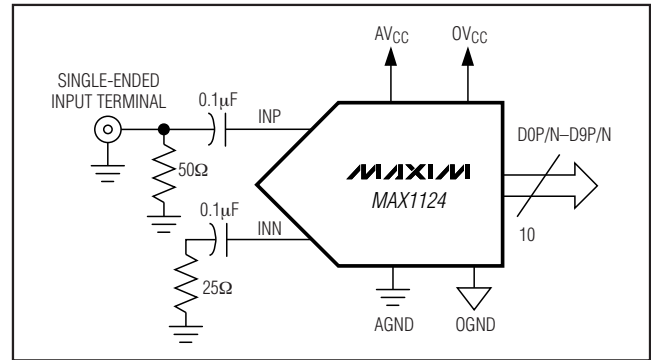

Figure 9. Single-Ended AC-Coupled Analog Input Configuration

Single-Ended, AC-Coupled Analog Input

Although not recommended, the MAX1124 can be used in single-ended mode (Figure 9). Analog signals can be AC-coupled to the positive input INP through a 0.1µF capacitor and terminated with a 50Ω resistor to AGND. The negative input should be 25Ω reverse-terminated and AC grounded with a 0.1µF capacitor.

Grounding, Bypassing, and Board Layout Considerations

The MAX1124 requires board layout design techniques suitable for high-speed data converters. This ADC provides separate analog and digital power supplies. The analog and digital supply voltage pins accept input voltage ranges of 1.7V to 1.9V. Although both supply types can be combined and supplied from one source, it is recommended to use separate sources to cut down on performance degradation caused by digital switching currents, which can couple into the analog supply network. Isolate analog and digital supplies (AVCC and OVCC) where they enter the PCB with separate networks

1.8V, 10-Bit, 250MSPS Analog-to-Digital Converter with LVDS Outputs for Wideband Applications

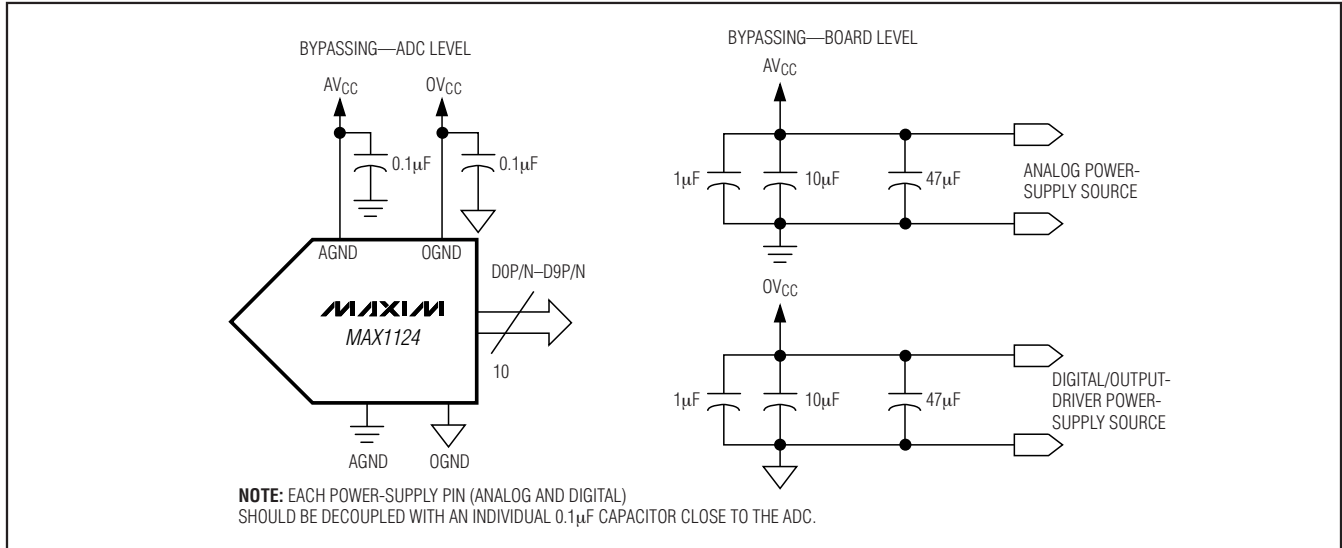

Figure 10. Grounding, Bypassing, and Decoupling Recommendations for the MAX1124

of ferrite beads and capacitors to their corresponding grounds (AGND, OGND).

To achieve optimum performance, provide each supply with a separate network of a 47µF tantalum capacitor in parallel with 10µF and 1µF ceramic capacitors. Additionally, the ADC requires each supply pin to be bypassed with separate 0.1µF ceramic capacitors (Figure 10). Locate these capacitors directly at the ADC supply pins or as close as possible to the MAX1124. Choose surface-mount capacitors, which are preferably located on the same side as the converter, to save space and minimize the inductance.

Multilayer boards with separated ground and power planes produce the highest level of signal integrity. Consider the use of a split ground plane arranged to match the physical location of analog and digital ground on the ADC's package. The two ground planes should be joined at a single point so the noisy digital ground currents do not interfere with the analog ground plane. A major concern with this approach are the dynamic currents that may need to travel long distances before they are recombined at a common source ground, resulting in large and undesirable ground loops. Ground loops can add to digital noise by coupling back to the analog front end of the converter, resulting in increased spur activity and a decreased noise performance.

Alternatively, all ground pins could share the same ground plane, if the ground plane is sufficiently isolated from any noisy, digital systems ground. To minimize the

effects of digital noise coupling, ground return vias can be positioned throughout the layout to divert digital switching currents away from the sensitive analog sections of the ADC. This does not require additional ground splitting, but can be accomplished by placing substantial ground connections between the analog front end and the digital outputs.

The MAX1124 is packaged in a 68-pin QFN-EP package (package code: G6800-4), providing greater design flexibility, increased thermal efficiency, and optimized AC performance of the ADC. **The EP must be soldered down to AGND.**

In this package, the data converter die is attached to an EP lead frame with the back of this frame exposed at the package bottom surface, facing the PCB side of the package. This allows a solid attachment of the package to the PCB with standard infrared (IR) flow soldering techniques.

Note that thermal efficiency is not the key factor, since the MAX1124 features low-power operation. The exposed pad is the key element to ensure a solid ground connection between the DAC and the PCB's analog ground layer.

Considerable care must be taken, when routing the digital output traces for a high-speed, high-resolution data converter. It is essential to keep trace lengths at a minimum and place minimal capacitive loading—less than 5pF—on any digital trace to prevent coupling to sensitive analog sections of the ADC. It is recommended to run the LVDS output traces as differential lines with

1.8V, 10-Bit, 250Mps Analog-to-Digital Converter with LVDS Outputs for Wideband Applications

100Ω characteristic impedance from the ADC to the LVDS load device.

Static Parameter Definitions

Integral Nonlinearity (INL)

Integral nonlinearity is the deviation of the values on an actual transfer function from a straight line. This straight line can be either a best straight-line fit or a line drawn between the end points of the transfer function, once offset and gain errors have been nullified. However, the static linearity parameters for the MAX1124 are measured using the histogram method with an input frequency of 10MHz.

Differential Nonlinearity (DNL)

Differential nonlinearity is the difference between an actual step width and the ideal value of 1 LSB. A DNL error specification of less than 1 LSB guarantees no missing codes and a monotonic transfer function. The MAX1124's DNL specification is measured with the histogram method based on a 10MHz input tone.

Dynamic Parameter Definitions

Aperture Jitter

Figure 11 depicts the aperture jitter (t_{AJ}), which is the sample-to-sample variation in the aperture delay.

Aperture Delay

Aperture delay (t_{AD}) is the time defined between the falling edge of the sampling clock and the instant when an actual sample is taken (Figure 11).

Signal-to-Noise Ratio (SNR)

For a waveform perfectly reconstructed from digital samples, the theoretical maximum SNR is the ratio of the full-scale analog input (RMS value) to the RMS quantization error (residual error). The ideal, theoretical minimum analog-to-digital noise is caused by quantization error only and results directly from the ADC's resolution (N bits):

$$SNR_{dB[max]} = 6.02dB \times N + 1.76dB$$

In reality, other noise sources such as thermal noise, clock jitter, signal phase noise, and transfer function nonlinearities are also contributing to the SNR calculation and should be considered when determining the SNR in ADC.

Signal-to-Noise Plus Distortion (SINAD)

SINAD is computed by taking the ratio of the RMS signal to all spectral components excluding the fundamental and the DC offset. In case of the MAX1124, SINAD is computed from a curve fit.

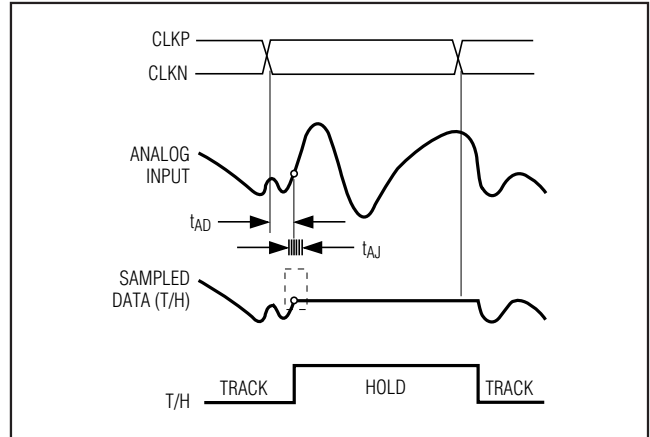

Figure 11. Aperture Jitter/Delay Specifications

Spurious-Free Dynamic Range (SFDR)

SFDR is the ratio of RMS amplitude of the carrier frequency (maximum signal component) to the RMS value of the next-largest noise or harmonic distortion component. SFDR is usually measured in dBc with respect to the carrier frequency amplitude or in dBFS with respect to the ADC's full-scale range.

Two-Tone Intermodulation Distortion (IMD)

The two-tone IMD is the ratio expressed in decibels of either input tone to the worst 3rd-order (or higher) intermodulation products. The individual input tone levels are at -7dB full scale.

Pin-Compatible Higher Speed/ Lower Resolution Versions

PART	RESOLUTION (Bits)	SPEED GRADE (Mps)
MAX1122	10	170
MAX1123	10	210
MAX1121	8	250

Package Information

For the latest package outline information and land patterns, go to www.maxim-ic.com/packages.

PACKAGE TYPE	PACKAGE CODE	DOCUMENT NO.
68 QFN-EP	G6800-4	21-0122

1.8V, 10-Bit, 250Msps Analog-to-Digital Converter with LVDS Outputs for Wideband Applications

Revision History

REVISION NUMBER	REVISION DATE	DESCRIPTION	PAGES CHANGED
0	10/03	Initial release	—
1	2/04	—	—
2	8/08	Minor corrections to the data sheet to fix problems found during off-shore transfer.	3, 4

MAX1124

Maxim cannot assume responsibility for use of any circuitry other than circuitry entirely embodied in a Maxim product. No circuit patent licenses are implied. Maxim reserves the right to change the circuitry and specifications without notice at any time.

Maxim Integrated Products, 120 San Gabriel Drive, Sunnyvale, CA 94086 408-737-7600 _____ 17