



DS5250

High-Speed Secure Microcontroller

General Description

The DS5250 is a highly secure, four clocks-per-machine cycle, 100% 8051-instruction-set-compatible microprocessor in Maxim's secure microcontroller family. It was designed to be the cryptographic engine of PIN pads, financial terminals, and any other application in which data security is paramount. A key feature of the device is that it encrypts its program memory and optionally its data memory with a hardware-based single- or triple-DES (data encryption standard) algorithm, making it almost impossible to extract information. It also implements block cipher encoding that uses block addresses to modify the encrypted data, further strengthening security. This makes the device ideal for storage and transmission of passwords, personal identification numbers, encryption keys, and other highly confidential information.

Applications

- PIN Pads
- Financial Terminals
- Data Security Applications

Ordering Information

PART	TEMP RANGE	PIN-PACKAGE
DS5250F-825	0°C to +70°C	80 MQFP
DS5250F-825+	0°C to +70°C	80 MQFP
DS5250F-8N5	-40°C to +85°C	80 MQFP
DS5250F-8N5+	-40°C to +85°C	80 MQFP
DS5250F-125	0°C to +70°C	100 MQFP
DS5250F-125+	0°C to +70°C	100 MQFP
DS5250F-1N5	-40°C to +85°C	100 MQFP
DS5250F-1N5+	-40°C to +85°C	100 MQFP

+Denotes a lead-free/RoHS-compliant package.

Pin Configurations and Selector Guide appear at end of data sheet.

Features

- ◆ **Feature-Rich, 8051-Compatible Microprocessor**
 - Accesses Up to 4MB Program and 4MB Data Memory (All Nonvolatile)
 - In-System Programmable Through Serial Port

- In-Application Programmable Through User Software
- Allows Self-Modification of Program/Data Memory
- Four 8-Bit Ports/One 6-Bit Port
- Three 16-Bit Timer/Counters
- 256 Bytes of Scratchpad RAM

- ◆ **Advanced Features**
 - CRC-16/32 Generator
 - 5KB Internal SRAM (Optional 1KB Stack)
 - Single or 3DES Engine
 - Partitionable Memory Segments Variable from 4KB to 256KB
- ◆ **High-Speed Architecture**
 - Four Clocks-per-Machine Cycle
 - DC-to-25MHz Operation
 - Single-Cycle Instruction in 160ns
 - Dual Data Pointers Can Increment or Decrement Independently
 - Automatic Data Pointer (DPTR) Selection Available
 - Programmable Speed MOVX Instructions
 - 1KB On-Chip Instruction Cache
- ◆ **High-Reliability Operation**
 - Power-Fail/Overvoltage Reset
 - Early-Warning Power-Fail Interrupt
 - Watchdog Timer
- ◆ **Nonvolatile Functions**
 - On-Chip Real-Time Clock with Alarm Interrupt
 - 2KB Battery-Backed Internal SRAM
- ◆ **Interrupts**
 - 15 Interrupts with Seven External Sources
- ◆ **Security Features**
 - Executes Single/3DES-Encrypted Programs to Prevent Observation
 - Two Self-Destruct Inputs
 - 4096-Bit Modulo-Arithmetic Accelerator (MAA) for Public/Private Key Operations
 - Tamper Sensors Detect
 - Thermal/Voltage/Probe Attacks
 - Programmable Attack Countermeasures
 - Secure-Loader Mode
 - True Random-Number Generator (RNG)
 - Unique ID Number in Every Device
 - Separate Program/Data Cryptograph
 - Program Memory Integrity Checking
- ◆ **Evaluation Kit Available (DS5250-KIT)**

Note: Some revisions of this device may incorporate deviations from published specifications known as errata. Multiple revisions of any device may be simultaneously available through various sales channels. For information about device errata, contact the factory.



ABRIDGED DATA SHEET

High-Speed Secure Microcontroller

DS5250

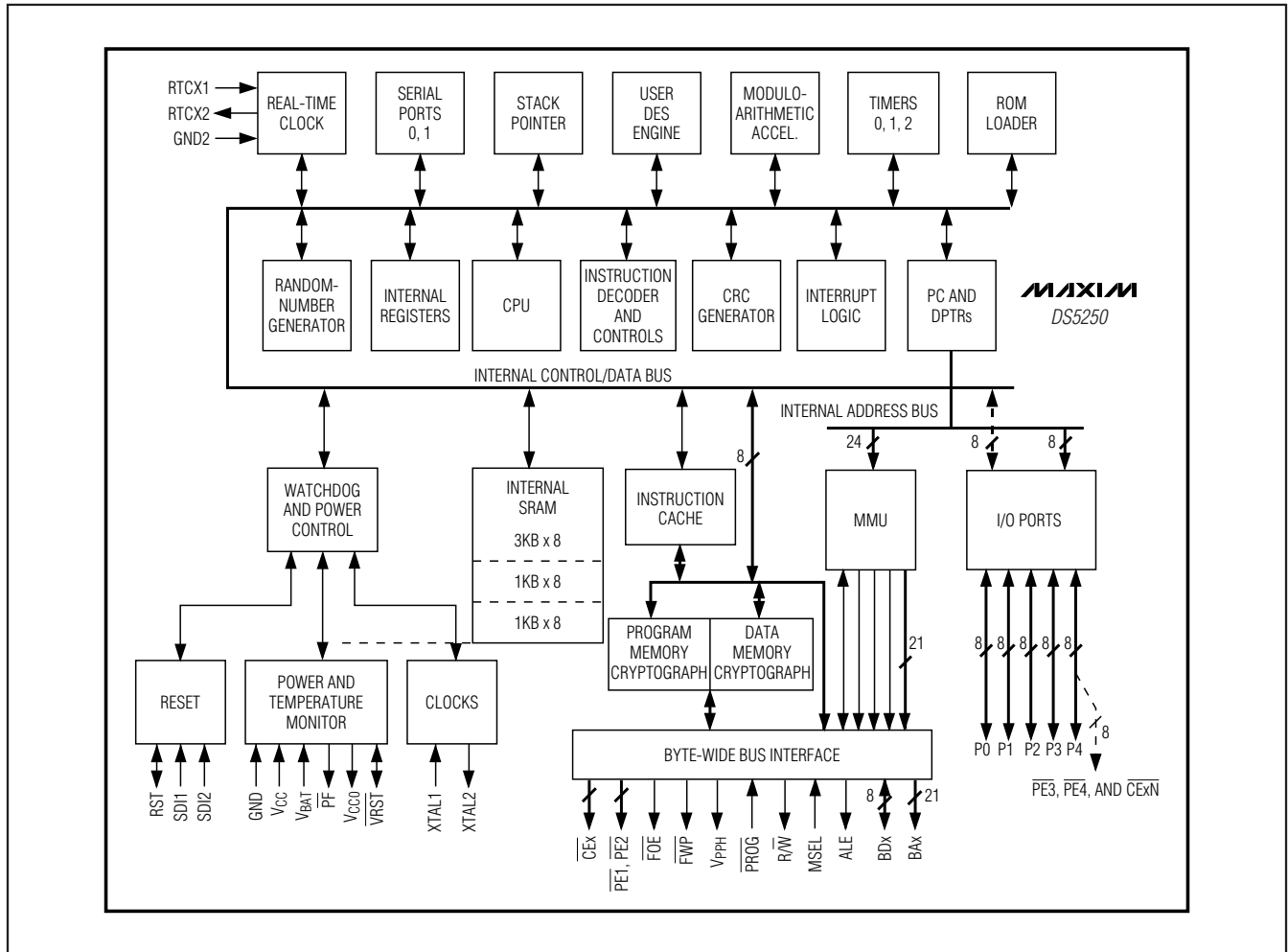

Figure 4. Block Diagram

Note to readers: This document is an abridged version of the full data sheet. To request the full data sheet, go to www.maxim-ic.com/DS5250 and click on **Request Full Data Sheet**.