

### GENERAL DESCRIPTION

The DS3174DK is an easy-to-use demo kit for the DS3174. A surface-mounted DS3174 and careful layout of the analog signal traces provide maximum signal integrity to demonstrate the transmit and receive capabilities of the DS3174. On-board Dallas 8051-compatible microcontroller and included software give point-and-click access to configuration and status registers from a personal computer. General-purpose LEDs on the board can easily be configured to indicate various alarm conditions for all four ports. The board provides eight BNC connectors for the line-side transmit and receive differential pairs, and two FPGAs to support overhead functions. All LEDs and connectors are clearly labeled with silkscreening to identify associated signals.

### DEMO KIT CONTENTS

- DS3174DK Board
- CD-ROM
  - ChipView Software
  - DS3174 Definition Files
  - DS3174DK Data Sheet
  - DS3174 Data Sheet

### ORDERING INFORMATION

PART	DESCRIPTION
DS3174DK	Demo Kit for the DS3174

### FEATURES

- Soldered DS3174 for Best Signal Integrity
- BNC Connectors, Transformers, and Termination Passives for All Four LIUs
- Careful Layout for Analog Signal Paths
- On-Board DS3, E3, and STS-1 Crystal Oscillators
- DS3174 Configured for CPU Bus Operation for Complete Control Over the Device
- On-Board Dallas Microcontroller and Included Software Provide Point-and-Click Access to the DS3174 Register Set
- General-Purpose LEDs can be Configured for Various Alarm Conditions
- Banana Jack Connectors for V<sub>DD</sub> and GND Support Use of Lab Power Supplies
- Separate DS3174 V<sub>DD</sub> to Allow I<sub>DD</sub> Measurements
- Easy-to-Read Silkscreen Labels Identify the Signals Associated with All Connectors, Jumpers, and LEDs

### DS3174 DEMO KIT BOARD

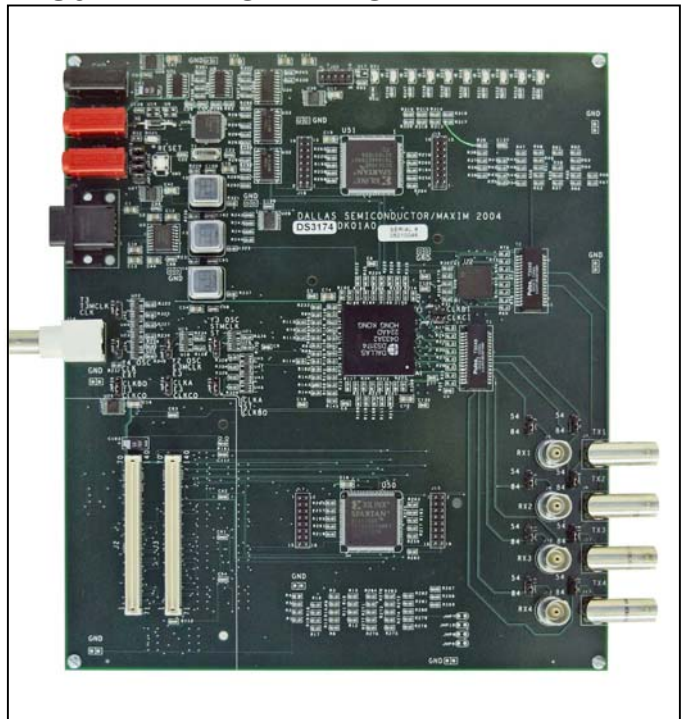

**COMPONENT LIST**

DESIGNATION	QTY	DESCRIPTION	MANUFACTURER	PART
C1, C2, C12, C13, C14, C18, C19, C44, C54, C57, C65, C69, C70, C74, C75	15	10 $\mu$ F $\pm$ 20%, 10V ceramic capacitors (1206)	Panasonic	ECJ-3YB1A106M
C3–C7, C9, C10, C11, C20, C21, C24–C38, C46, C47, C58–C64, C66, C67, C68, C76–C87, C95, C98, C100, C102, C109–C137	82	0.1 $\mu$ F $\pm$ 20%, 16V X7R ceramic capacitors	AVX	0603YC104MAT
C8, C15, C39, C40	4	4.7 $\mu$ F $\pm$ 10%, 25V X5R ceramic capacitors	Panasonic	ECJ-3YB1E475K
C16, C17, C41, C42	4	6.8 $\mu$ F 10%, 6.3V X5R ceramic capacitors (1206)	Panasonic	ECJ-3YB0J685K
C22, C23	2	22pF $\pm$ 5%, 25V NPO ceramic capacitors	AVX	06033A220JAT
C43, C103	2	68 $\mu$ F $\pm$ 20%, 16V tantalum capacitors (D case)	Panasonic	ECS-T1CD686R
D1	1	Diode, 1A, 50V, general-purpose silicon	General Semiconductor	1N4001
DS1, DS10	2	Green SMD LEDs	Panasonic	LN1351C
DS2–DS9	8	Red SMD LEDs	Panasonic	LN1251C
DS21	1	Red SMD LED	Panasonic	LN1251C
J1, J4	2	Sockets, banana plug, horizontal, red	Mouser (distributor)	164-6219
J2, J3	2	Plugs, SMD, 140-pin, 0.8mm, 2-row vertical	AMP	179031-6
J5	1	Socket, banana plug, horizontal, black	Mouser (distributor)	164-6218
J6, J8, J10, J12	4	BNC connectors 75 $\Omega$ , vertical, 5-pin	Cambridge	CP-BNCPC-004
J7, J9, J11, J13	4	Connector, BNC, 75 ohm, right angle, 5-pin	Trompeter	UCBJR220
J14	1	Amphenol, right-angle BNC	Amphenol	31-5431
J15–J18	4	Terminal strip, 16-pin, dual-row, vertical	Samtec	TSW-108-07-T-D
J21	1	Connector, DB9, right-angle, long case	AMP	747459-1
J25	1	Terminal strip, 10-pin, dual-row, vertical	—	—
JMP1, JMP2, JMP15	3	2-pin header, 0.100 centers, vertical	Samtec	TSW-102-07-T-S
JMP3–JMP6, JMP11–JMP14, JMP16, JMP17, JMP18, JMP23–JMP26	15	3-pin header, 0.100 centers, vertical	Samtec	TSW-103-07-T-S
JMP7–JMP10, JMP19–JMP22	8	Do not place, open 2 pin TH jumper	—	—
R1, R2, R3, R16–R19, R36–R39, R41–R51, R53–R59, R61–R68, R229–R231, R244	41	0 $\Omega$ $\pm$ 1%, 1/16W resistors (0603)	AVX	CJ10-000F
R4, R146, R147, R148, R158, R159, R160	7	Resistors (0603) Do not populate	—	—
R5, R8–15, R92, R93, R95, R161, R270–R285, R313–R320	37	10k $\Omega$ $\pm$ 5%, 1/16W resistors (0603)	Panasonic	ERJ-3GEYJ103V

DESIGNATION	QTY	DESCRIPTION	MANUFACTURER	PART
R6, R7, R28–R35, R77–R91, R94, R96–R145, R149– R157, R162–R228, R233–R240, R255– R266, R305–R312, R321–R329	189	33Ω ±5%, 1/16W resistors (0603)	Panasonic	ERJ-3GEYJ330V
R20–R27, R69–R76	16	332Ω ±1%, 1/16W resistors (0603)	Panasonic	ERJ-3EKF3320V
R52, R246–R254	10	330Ω ±5%, 1/16W resistors (0603)	Panasonic	ERJ-3GEYJ331V
R232	1	51.1Ω ±1%, 1/16W resistor (0603)	Panasonic	ERJ-3EKF51R1V
R241	1	3.3kΩ ±5%, 1/16W resistor (0603)	Panasonic	ERJ-3GEYJ332V
R242, R243, R245, R267, R268, R269	6	4.7kΩ ±5%, 1/16W resistors (0603)	Panasonic	ERJ-3GEYJ472V
R286–R304, R330	20	100Ω ±5%, 1/16W resistors (0603)	Panasonic	ERJ-3GEYJ101V
SW5	1	Switch, momentary, 4-pin, single pole	Panasonic	EVQPAE04M
T1, T2	2	Octal T3/E3 transformers, 1 to 2, SMD 32-pin	Pulse Engineering	T3049
TP3–TP10, TP17, TP21–TP32, TP70	22	Test points, 1 plated hole, do not stuff	—	—
U1	1	Quad DS3/E3 single-chip transceiver (400-pin CSBGA)	Dallas Semiconductor	DS3174
U2	1	Quad DS3/E3/STS1 LIU (144-pin CSBGA)	Dallas Semiconductor	DS3154
U3	1	Dual RS-232 transmitter/receiver (16-pin SO, 300 mils)	Dallas Semiconductor	DS232AS
U4, U5, U6, U10, U11, U12	6	IC, 3.3V octal buffer/driver (20-pin narrow SOP)	Texas Instruments	SN74ALVC244NSR
U8	1	IC, 3-line to 8-line decoder/demultiplexer (16-pin SOIC)	Texas Instruments	SN74HC138NSR
U9	1	Microprocessor voltage monitor, 3.08V reset (4-pin SOT143)	Maxim	MAX811TEUS-T
U13	1	IC, TinyLogic ultra-high-speed 2-input exclusive- OR gate (5-pin SOT23)	Fairchild	NC7SZ86M5
U14	1	Microprocessor voltage monitor, 4.38V reset (4-pin SOT143)	Maxim	MAX812MEUS-T
U17	1	Microprocessor reset circuit, 3.08V reset (3-pin SC70)	Maxim	MAX803TEXR-T
U18–U25, U41–U46	14	IC, TinyLogic ultra-high-speed 2-input OR gate (5-pin SOT23)	Fairchild	NC7SZ32M5
U26, U27, U29	3	3.3V linear regulator (16-pin TSSOP-EP)	Maxim	MAX1793EUE-33
U28	1	IC, Xilinx platform flash in-system-programmable config PROM (20-pin TSSOP)	Xilinx	XCF04SVO20C
U30	1	1.8V linear regulator (16-pin TSSOP-EP)	Maxim	MAX1793EUE-18
U31	1	IC, hex inverter, SOIC	Toshiba	TC74HC04AFN



## BOARD FLOOR PLAN

Figure 1 shows the floor plan of the DS3174DK. The DS3174 is near the center of the board. The analog circuitry is on the right side of the board, which includes transformers and BNC connectors. There is an optional external LIU (DS3154) that can be used in certain configurations. Located one above and one below of the DS3174 are two FPGAs that, along with headers, provide access to the overhead signals. The microprocessor is on the left top of the board, clock distribution is in the left center, and system interface is at the left bottom. General-purpose LEDs, which are driven by configurable outputs, are located at the top of the board. In the upper-left corner are banana jacks for ground, 5V (regulated to provide board  $V_{DD}$ ), and a separate DS3174  $V_{DD}$  (useful for DS3174  $I_{DD}$  measurements). There are connectors provided for the serial interface to the microprocessor and the JTAG chain. The board also contains DS3, E3, and STS-1 oscillators and the necessary jumpers to configure both the DS3174 and the DS3154 clocking.

Figure 1. Board Floor Plan

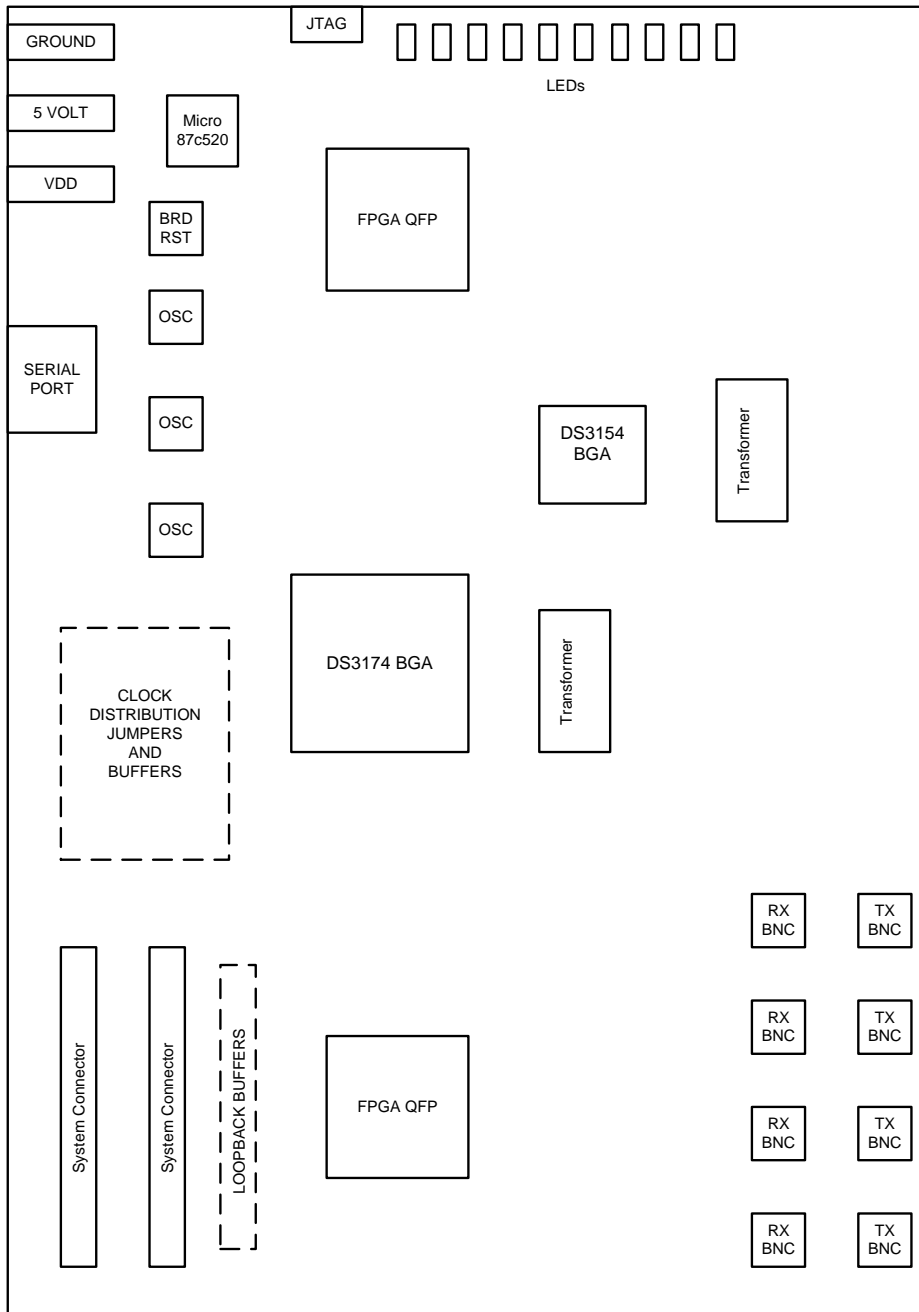

## CLOCK JUMPERS

Jumper JMP16 (middle left of board) selects the clock source (external BNC or on-board oscillator) for both CLKA and the system clocks on the DS3174. Jumpers JMP17, JMP18, and JMP23 select the source of the clocks to the external LIU (DS3154), which can be on-board oscillators or a CLAD output of the DS3174. Jumpers JMP24, JMP25, and JMP26 select the specific CLAD output to be connected to the LIU clock inputs on the DS3154.

## LINE-SIDE CONNECTIONS

The DS3174DK implements the transmit (Tx) and receive (Rx) line interface networks recommended in the DS3174 data sheet and shown in [Figure 2](#). The BNC connectors for LIU1 are labeled TX1 and RX1. The BNC connectors for LIU2 are labeled TX2 and RX2. The BNC connectors for LIU3 are labeled TX3 and RX3. The BNC connectors for LIU4 are labeled TX4 and RX4.

**Figure 2. Line-Side Circuitry**

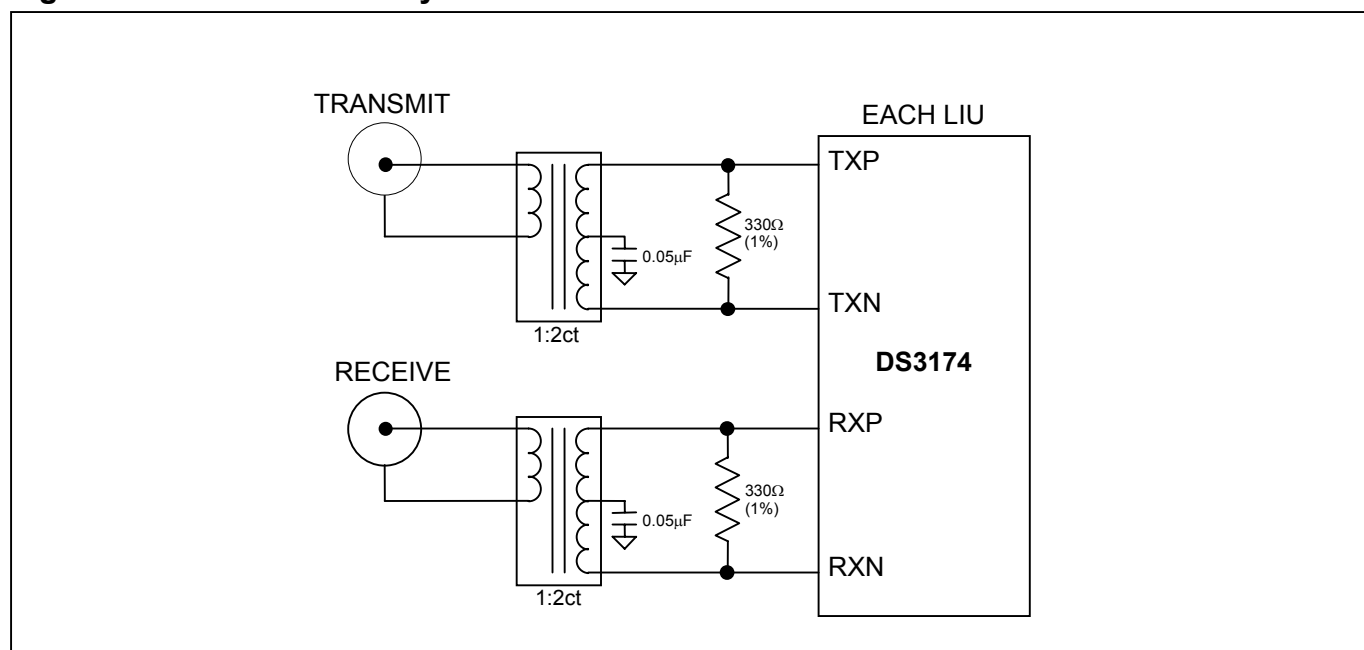

## SYSTEM CONNECTOR

The system interface connectors J2 and J3 are not used on the DS3174DK version of this board.

## MICROCONTROLLER

The DS87C520 microcontroller has factory-installed firmware in on-chip nonvolatile memory. This firmware translates memory access requests from the RS-232 serial port into register accesses on the DS3174. When the microcontroller starts up it turns on DS1, a green LED, to indicate that the controller is working correctly.

## POWER-SUPPLY CONNECTORS

Connect a 5.0V power supply with a current rating of at least 1 amp across the red J1 and black J5 (GND) banana jacks for normal operation. Banana jack J4 accommodates DS3174 IDD measurements. This is accomplished by disconnecting the DS3174 VDD connections from the board VDD by removing jumpers 19, 20, 21, and 22. Diode D1 provides protection against power connection reversal. The LED DS21 provides indications that a 5V supply is connected properly. The 5V supply is regulated to supply proper voltages to various circuits on the board.

## CONNECTING TO A COMPUTER

Connect a standard DB-9 serial cable between the serial port on the DS3174DK and an available serial port on the host computer. The host computer must be a Windows®-based PC. Be sure the cable is a standard straight-through cable rather than a null-modem cable. Null-modem cables prevent proper operation.

## INSTALLING AND RUNNING THE SOFTWARE

ChipView is a general-purpose program that supports a number of Dallas Semiconductor demo kits. To install the ChipView software, run SETUP.EXE from the disk included in the DS3174DK box or from the zip file downloadable on our website at [www.maxim-ic.com/DS3174DK](http://www.maxim-ic.com/DS3174DK).

After installation, run the ChipView program with the DS3174DK board powered up and connected to the PC. If the default installation options were used, one easy way to run ChipView is to click the **Start** button on the Windows toolbar and select Programs→ChipView→ChipView. In the opening screen, click the **Register View** button. (The **Demo** and **Terminal** buttons are not supported for the DS3174DK.) Select the correct serial port in the *Port Selection* dialog box, then click OK.

Next, the *Definition File Assignment* window appears. This window has subwindows to select definition files for up to four separate boards on other Dallas evaluation platforms. Because ChipView is communicating with the DS3174DK, only one subwindow is active. In the active subwindow, select the **DS3174.DEF** definition file from the list shown, or browse to find it in another directory. Press the **Continue** button.

After selecting the definition file, the main part of the ChipView window displays the DS3174's register map (described in the DS3174 data sheet). To select a register, click on it in the register map. When a register is selected, the full name of the register and its bit map are displayed at the bottom of the ChipView window. Bits that are logic 0 are displayed in white, while bits that are logic 1 are displayed in green.

The ChipView software supports the following actions:

- **Toggle a bit.** Select the register in the register map and then click the bit in the bit map.
- **Write a register.** Select the register, click the **Write** button, and enter the value to be written.
- **Write all registers.** Click the **Write All** button and enter the value to be written.
- **Read a register.** Select the register in the register map and click the **Read** button.
- **Read all registers.** Click the **Read All** button.

*Windows is a registered trademark of Microsoft Corp.*

## BASIC DS3174DK CONFIGURATION

The following example DS3 configuration provides a quick start to using the DS3174DK. The DS3174 and the DS3174DK can be configured in many other ways. To set up other configurations, refer to Section 9 of the DS3174 data sheet and other sections of this data sheet.

The following configuration supports port 1 only. The same directions apply for additional ports using the DEF files that support the specific port.

- Connect 5V between J1 and J5 and verify that jumpers 19 through 22 are installed. Verify LEDs DS1 and DS21 are on. Connect 75Ω coaxial cables to connectors J6 (Rx) and J7 (Tx). Verify J3 and J4 jumpers are set to the 84 position.
- Connect the serial port of a computer to J21. Run the ChipView application and load the definition file named DS3174.DEF provided with the kit.

The following registers in the DS3174 need to be configured. For ChipView-specific help, review the ChipView manual.

Select “DS3174.def slot\_0” from the “DEF File Selection” Menu

Click Read All

Put DS3174 in known condition with all registers set to their default value by initiating a Global Reset

```
SET      GCR1L.RST
CLEAR    GCR1L.RST
CLEAR    GCR1L.RSTDP          clear data path resets
```

Note: To configure all 4 ports simultaneously, set GCR1U.GWRM.

```
SET      GCR1U.SIW[1:0]  =    01    16 bit system interface
SET      GCR1U.SIM[1:0]  =    11    POS PHY L3
```

Note: UTOPIA L2 is the default setting: GCR1U.SIM[1:0] = 00

Configure internal CLAD

Note: The following CLAD configuration requires a DS3 clock applied to CLKA (CLKB and CLKC are driven low).

See CLAD table in DS317x data sheet for other configurations

```
CLEAR    GCR2L.CLAD3
SET      GCR2L.CLAD2
CLEAR    GCR2L.CLAD1
CLEAR    GCR2L.CLAD0
```

Select “ports.def slot\_0” from the “DEF File Selection” Menu

Click Read All

---

CLEAR	PCR1L.RSTDP	normal operation
CLEAR	PCR1L.PD	
SET	PCR1U.PAIS2	disable payload AIS
SET	PCR1U.PAIS1	
SET	PCR1U.PAIS0	
SET	PCR1U.LAIS1	disable line AIS
SET	PCR1U.LAIS0	

### Configure the Framer and LIU

For DS3 C-bit format (default mode)

CLEAR	PCR2L.FM5
CLEAR	PCR2L.FM4
CLEAR	PCR2L.FM3
CLEAR	PCR2L.FM2
CLEAR	PCR2L.FM1
CLEAR	PCR2L.FM0

SET	PCR2U.LM0	LIU on, No JA
SET	PCR2U.LM1	JA on in RX path

## PC BOARD LAYOUT RECOMMENDATIONS

Standard high-speed layout guidelines should be observed when designing a PC board to support the DS3174. The following guidelines help to provide stable supply voltages and signal integrity between devices. The DS3174 should have a low-impedance power-supply path that is accomplished with plane layers and an appropriate decoupling scheme. Decoupling capacitors should be connected directly to the planes with minimal trace length. Surface-mount ceramic capacitors should be used with one 0.1 $\mu$ F per power pin to provide adequate decoupling. Bulk capacitors of the higher capacitance tantalum type should be used near the power-supply connections to provide low-frequency decoupling. All high-speed connections to the DS3174 should be designed with controlled impedance and proper terminations to prevent reflections. The differential connections to the primary or system side of the transformer should be short traces from the DS3174 run together with respect to differential pairs. The connections on the secondary or network side of the transformers should be 75 $\Omega$  controlled impedance traces.

## DS3174 INFORMATION

The DS3174 Quick View page on our website has the latest DS3174 data sheet, application notes, and downloads. Go to [www.maxim-ic.com/DS3174](http://www.maxim-ic.com/DS3174).

## DS3174DK INFORMATION

The DS3174DK Quick View page on our website has the latest DS3174DK data sheet, ChipView software updates, and downloads. Go to [www.maxim-ic.com/DS3174DK](http://www.maxim-ic.com/DS3174DK).

## TECHNICAL SUPPORT

For additional technical support, please email your questions to [telecom.support@dalsemi.com](mailto:telecom.support@dalsemi.com).

## SCHEMATICS

The following 13 pages provide the schematic diagram of the DS3174DK.

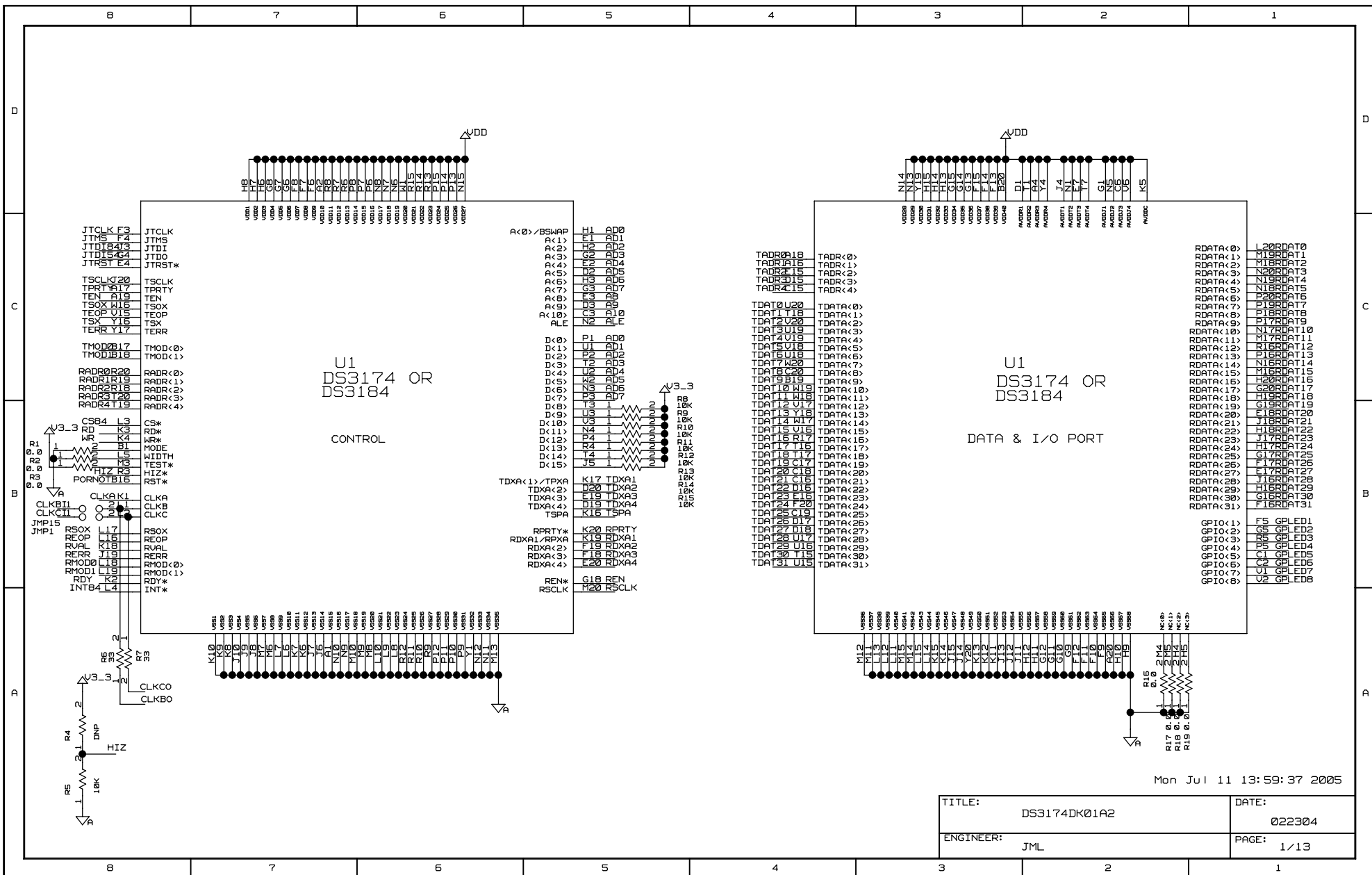

Mon Jul 11 13:59:37 2005

TITLE:	DS3174DK01A2	DATE:	022304
ENGINEER:	JML	PAGE:	1/13



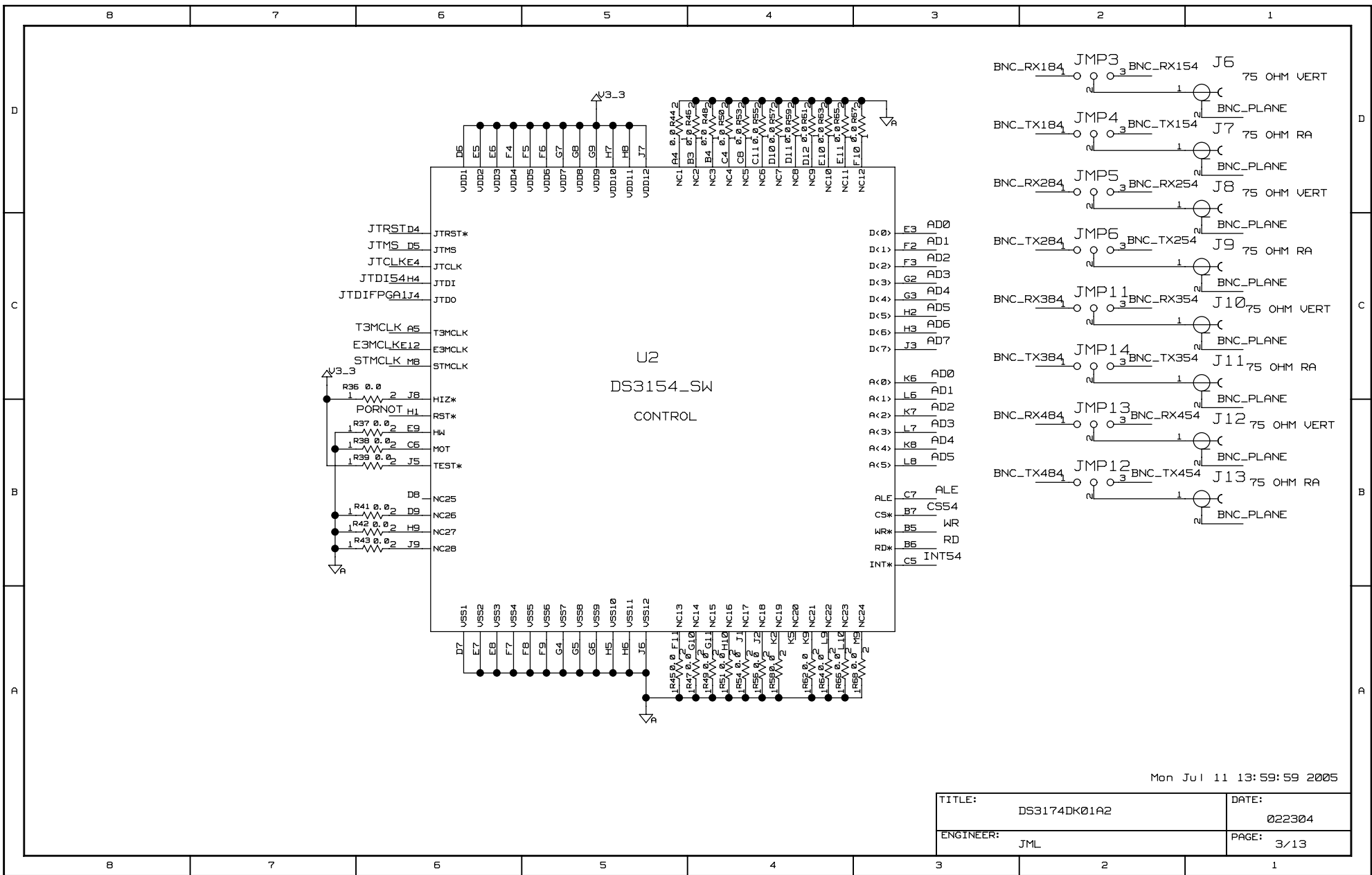

Mon Jul 11 13:59:59 2005

TITLE:	DS3174DK01A2	DATE:	022304
ENGINEER:	JML	PAGE:	3/13

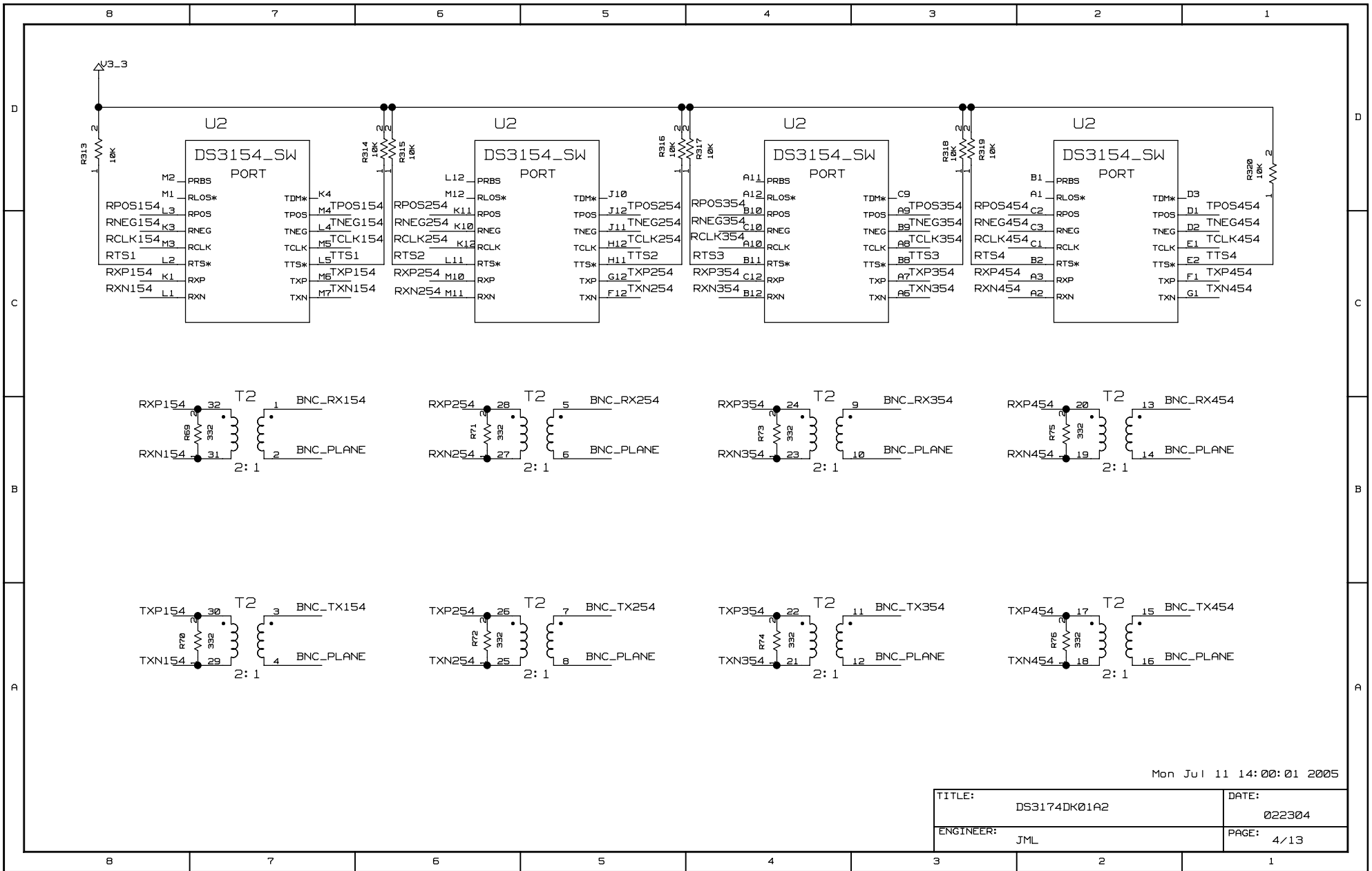

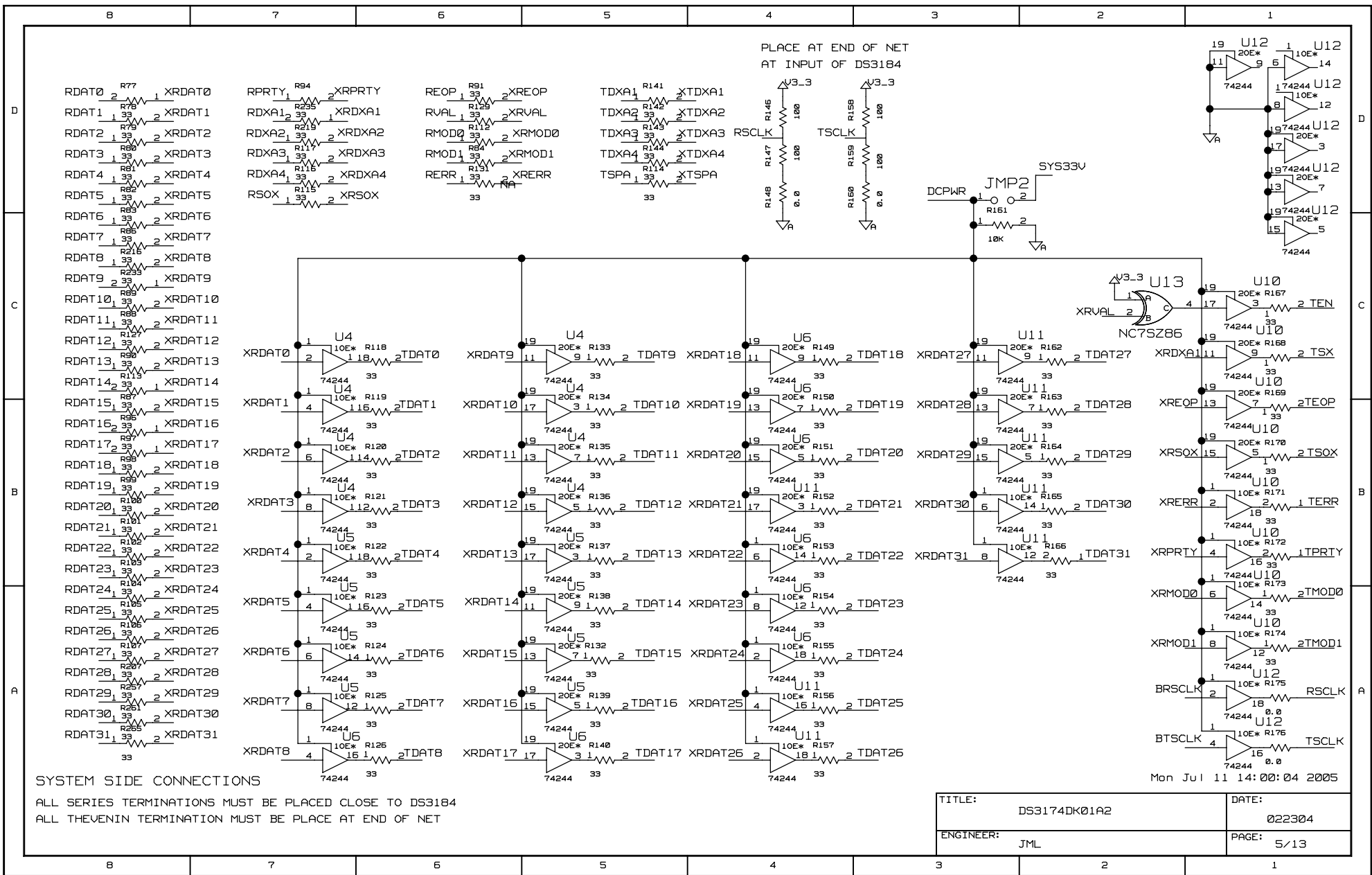

SYSTEM SIDE CONNECTIONS

ALL SERIES TERMINATIONS MUST BE PLACED CLOSE TO DS3184  
 ALL THEVENIN TERMINATION MUST BE PLACE AT END OF NET

TITLE:	DS3174DK01A2	DATE:	022304
ENGINEER:	JML	PAGE:	5/13

Mon Jul 11 14:00:04 2005

D

C

B

A

D

C

B

A

PLUG  
P1  
J3

TDAT0	1	1	71	71	GND
TDAT2	2	2	72	72	GND
GND	3	3	73	73	TDAT3
TDAT4	4	4	74	74	TDAT3
TDAT5	5	5	75	75	GND
GND	6	6	76	76	TDAT5
GND	7	7	77	77	TDAT7
TDAT9	8	7	77	78	SYS33V
GND	9	8	78	79	TDAT8
TDAT11	10	10	80	80	TDAT10
TDAT13	11	11	81	81	GND
TDAT14	12	12	82	82	TDAT12
TDAT14	13	13	83	83	
TDAT16	14	14	84	84	GND
GND	15	15	85	85	TDAT15
TDAT18	16	16	86	86	TDAT17
TDAT20	17	17	87	87	GND
GND	18	18	88	88	TDAT19
TDAT23	19	19	89	89	TDAT21
GND	20	20	90	90	SYS33V
TDAT23	21	21	91	91	TDAT22
GND	22	22	92	92	TDAT24
TDAT25	23	23	93	93	GND
TDAT27	24	24	94	94	TDAT26
TDAT28	25	25	95	95	
TDAT30	26	26	96	96	GND
GND	27	27	97	97	TDAT29
TDAT32	28	28	98	98	TDAT31
TDAT34	29	29	99	99	GND
TADR0	30	30	100	100	TSDX
GND	31	31	101	101	TADR1
TADR3	32	32	102	102	SYS33V
GND	33	33	103	103	TADR2
XTDXA1	34	34	104	104	TADR4
XTDXA3	35	35	105	105	GND
XTDXA4	36	36	106	106	XTDXA2
GND	37	37	107	107	
GND	38	38	108	108	GND
GND	39	39	109	109	
GND	40	40	110	110	GND
GND	41	41	111	111	
GND	42	42	112	112	
GND	43	43	113	113	
GND	44	44	114	114	SYS33V
TEN	45	45	115	115	
GND	46	46	116	116	TEOP
TEPR	47	47	117	117	GND
TMOD1	48	47	117	118	TMOD0
TSX	49	49	119	119	
TSCLK	50	50	120	120	GND
GND	51	51	121	121	XTSPA
GND	52	52	122	122	
GND	53	53	123	123	GND
GND	54	54	124	124	
GND	55	55	125	125	
GND	56	56	126	126	SYS33V
GND	57	57	127	127	
GND	58	58	128	128	GND
ADD	59	59	129	129	
ADD	60	60	130	130	
AD1	61	61	131	131	GND
AD3	62	62	132	132	AD2
GND	63	63	133	133	AD4
AD5	64	64	134	134	GND
AD7	65	65	135	135	GND
GND	66	66	136	136	AD6
GND	67	67	137	137	CSA
RD	68	68	138	138	SYS33V
GND	69	69	139	139	CSB
GND	70	70	140	140	WR

PLUG  
P2  
J2

XRDAT0	1	1	71	71	GND
XRDAT2	2	2	72	72	XRDAT1
GND	3	3	73	73	XRDAT3
XRDAT4	4	4	74	74	XRDAT3
XRDAT5	5	5	75	75	GND
GND	6	6	76	76	XRDAT5
GND	7	7	77	77	XRDAT7
XRDAT9	8	7	77	78	SYS33V
XRDAT9	9	8	78	79	XRDAT8
GND	10	10	80	80	XRDAT10
XRDAT11	11	11	81	81	GND
XRDAT13	12	12	82	82	XRDAT12
XRDAT14	13	13	83	83	
XRDAT14	14	14	84	84	GND
XRDAT16	15	15	84	85	XRDAT15
GND	16	16	85	86	XRDAT17
XRDAT18	17	17	86	87	GND
XRDAT20	18	18	88	88	XRDAT19
GND	19	19	89	89	XRDAT21
XRDAT23	20	20	90	90	SYS33V
XRDAT23	21	21	91	91	XRDAT22
XRDAT25	22	22	92	92	XRDAT24
XRDAT27	23	23	93	93	GND
XRDAT27	24	24	94	94	XRDAT26
XRDAT28	25	25	95	95	
XRDAT28	26	26	96	96	GND
XRDAT30	27	27	97	97	XRDAT29
GND	28	28	98	98	XRDAT31
XRPRTY	29	29	99	99	GND
XRSOX	30	30	100	100	XRVAL
GND	31	31	101	101	XRDXA1
XRMOD1	32	32	102	102	SYS33V
GND	33	33	103	103	XRMOD0
GND	34	34	104	104	XRRER
XREOP	35	35	105	105	GND
RADRL	36	36	106	106	RADR0
RADR2	37	37	107	107	
RADR4	38	38	108	108	GND
GND	39	39	109	109	RADR3
XRDXA3	40	40	110	110	XRDXA2
GND	41	41	111	111	GND
GND	42	42	112	112	XRDXA4
GND	43	43	113	113	
GND	44	44	114	114	SYS33V
GND	45	45	115	115	
GND	46	46	116	116	GND
GND	47	47	117	117	
REN	48	48	118	118	
REN	49	49	119	119	GND
GND	50	50	120	120	GND
GND	51	51	121	121	RSCLK
GND	52	52	122	122	
GND	53	53	123	123	GND
GND	54	54	124	124	
GND	55	55	125	125	
GND	56	56	126	126	SYS33V
A1	57	57	127	127	A0
GND	58	58	128	128	A2
A3	59	59	129	129	GND
A5	60	60	130	130	A4
A6	61	61	131	131	GND
A8	62	62	132	132	A7
GND	63	63	133	133	A9
A10	64	64	134	134	GND
GND	65	65	135	135	GND
GND	66	66	136	136	A11
GND	67	67	137	137	
GND	68	68	138	138	ICPWR
GND	69	69	139	139	
GND	70	70	140	140	

Mon Jul 11 14:00:07 2005

TITLE:	DS3174DK01A2	DATE:	022304
ENGINEER:	JML	PAGE:	6 OF 13

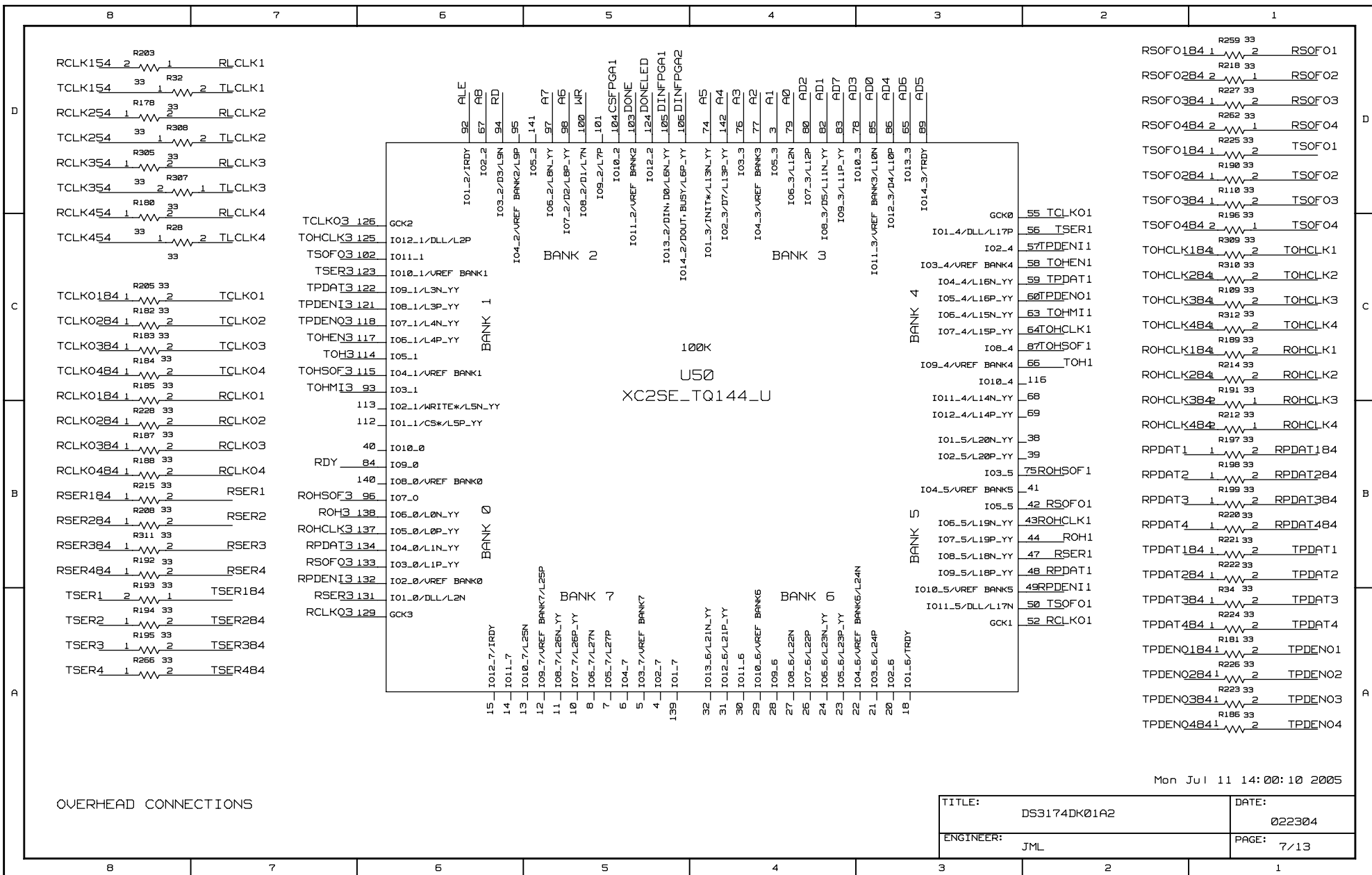

OVERHEAD CONNECTIONS

Mon Jul 11 14:00:10 2005

TITLE:	DS3174DK01A2	DATE:	022304
ENGINEER:	JML	PAGE:	7/13

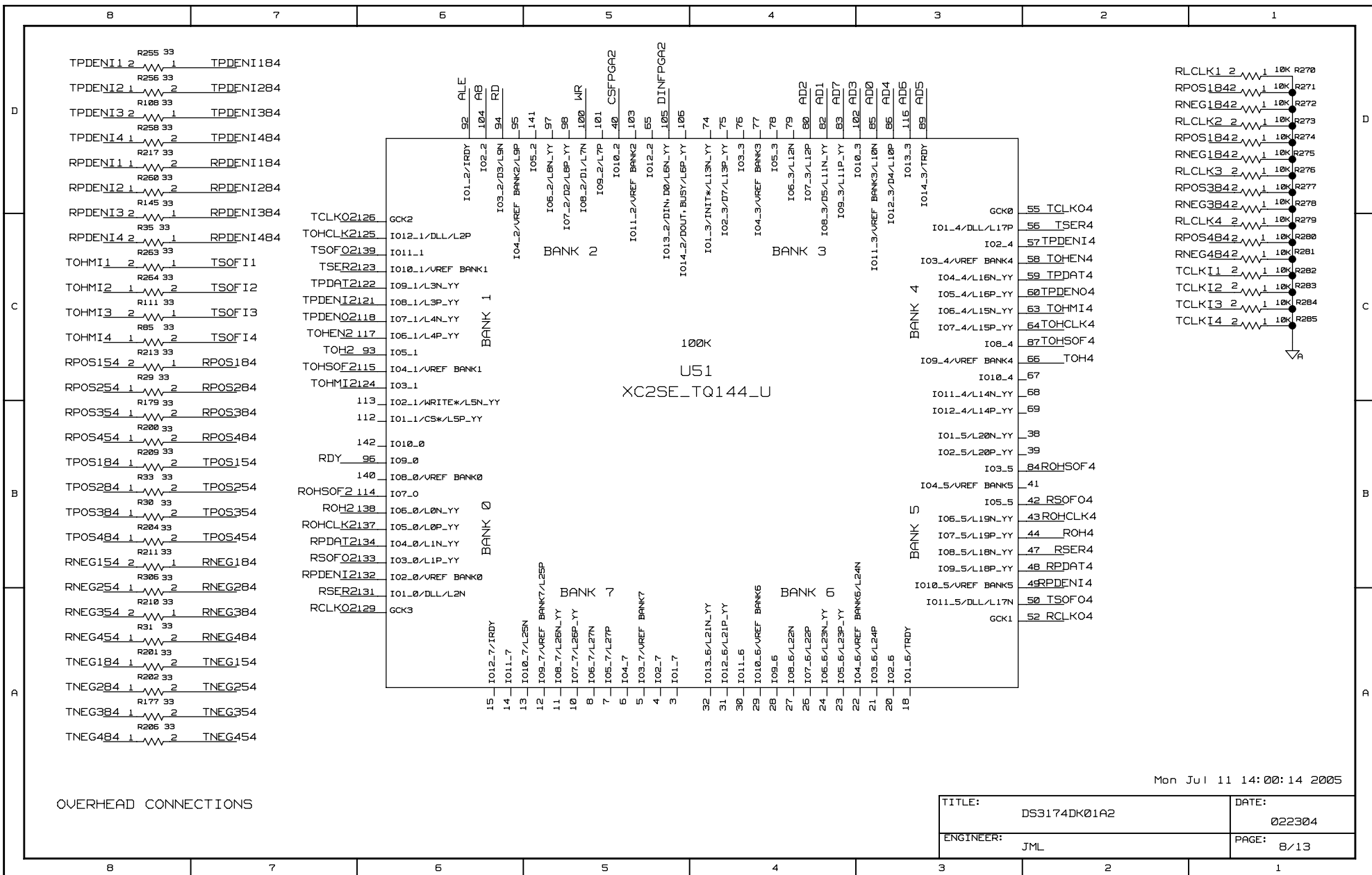

OVERHEAD CONNECTIONS

Mon Jul 11 14:00:14 2005

TITLE:	DS3174DK01A2	DATE:	022304
ENGINEER:	JML	PAGE:	8/13

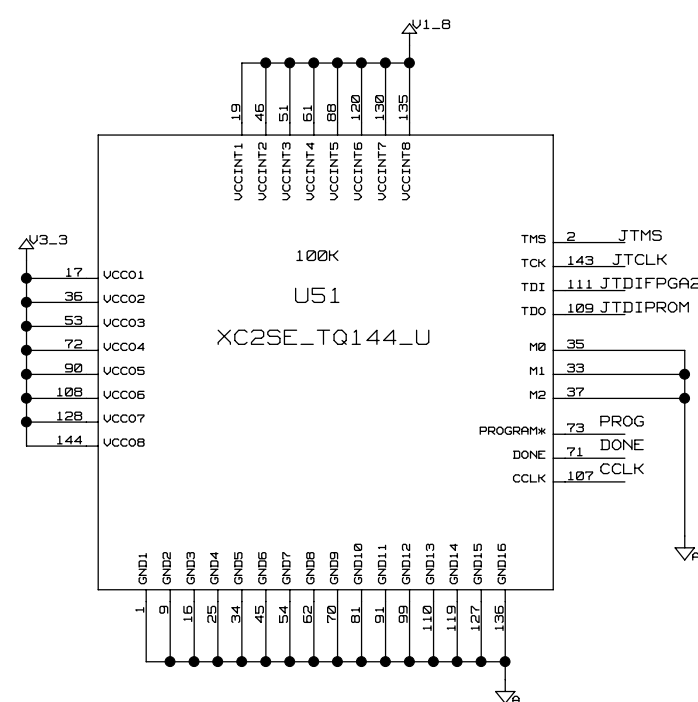
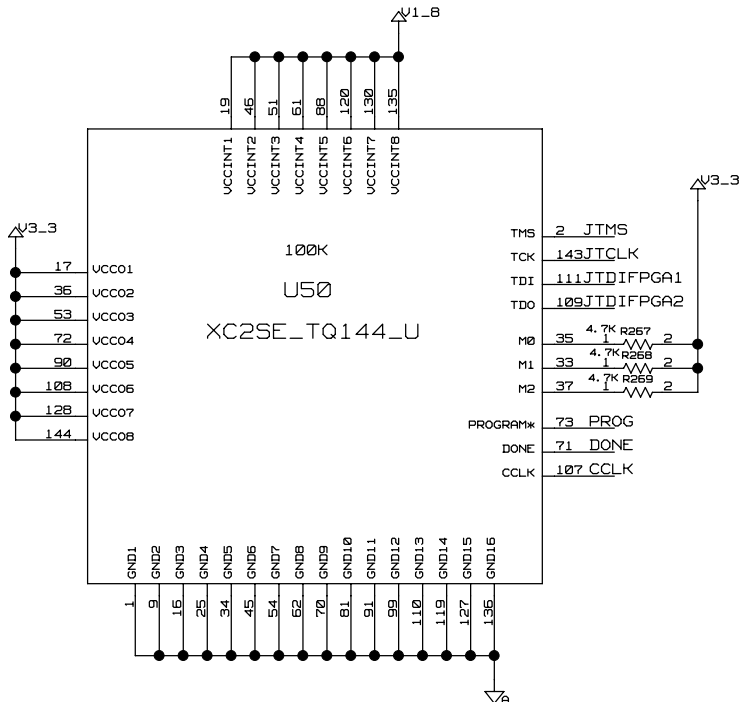
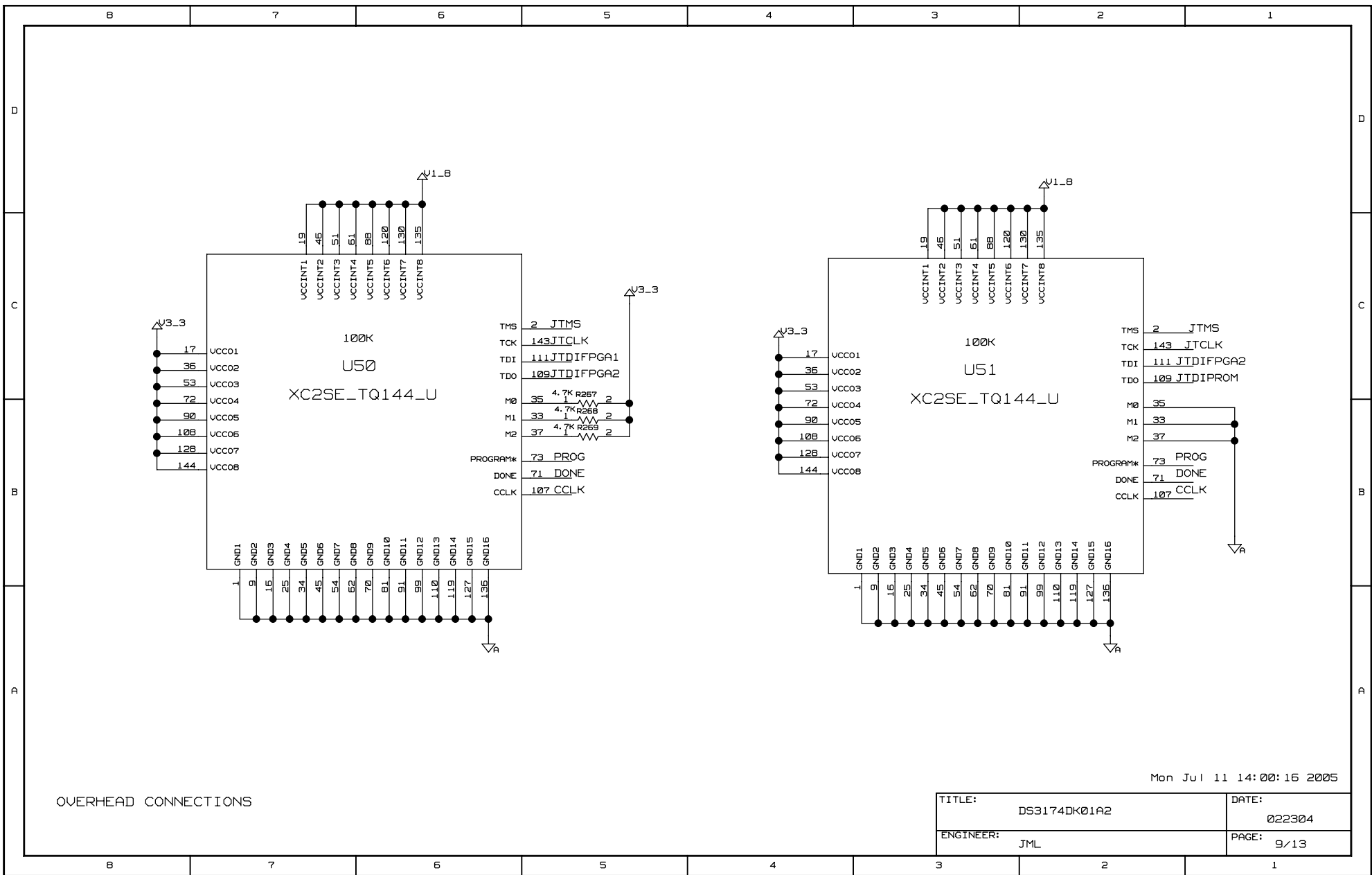

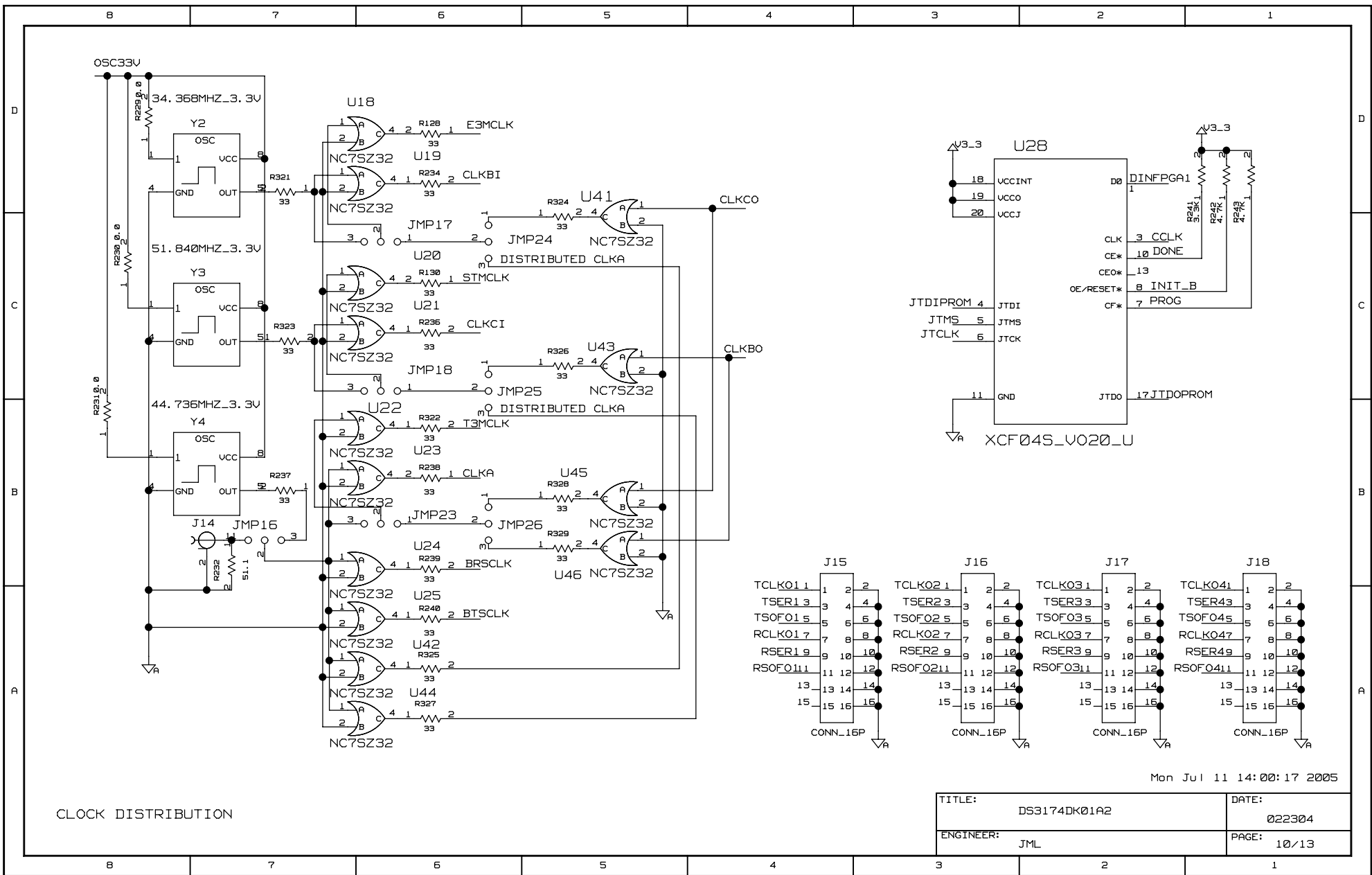

Mon Jul 11 14:00:17 2005

TITLE:	DS3174DK01A2	DATE:	022304
ENGINEER:	JML	PAGE:	10/13





REVISION HISTORY -

- 062904 - A0 - INITIAL RELEASE
- 040805 - A1 - ADDED MISSING SIGNAL NAMES ON PAGE 12 & CLEANED-UP TEXT ON VARIOUS PAGES.
- 070705 - A2 - ADDED VDD CONNECTION TO TTS/RTS NET  
FIXED XRM0D1/RVAL CONNECTIONS  
FIXED ALE SHORT ACROSS U34  
CHANGED R92 VALUE TO 330 OHMS  
CHANGED R175 AND R176 TO 33 OHMS FROM 0  
CHANGED R148 AND R160 FROM DNP TO 0  
CHANGED R146, R147, R158, R159 FROM DNP TO 100 OHMS  
CHANGED JMP19 TO JMP22 FROM DNP TO PLACE  
ALL A2 CHANGES ARE DOCUMENT CHANGES TO MATCH MODIFIED BOARDS WITH SCHEMATIC

TITLE:	DS3174DK01A2	DATE:	022304
ENGINEER:	JML	PAGE:	13 OF 13